

Excellent Integrated System Limited

Stocking Distributor

Click to view price, real time Inventory, Delivery & Lifecycle Information:

[FCI](#)

[66011-002LF](#)

For any questions, you can email us directly:

sales@integrated-circuit.com



All rights strictly reserved. Reproduction or issue to third parties in any form or by any means, electronic or mechanical, including photocopying, recording, or by any information storage and retrieval system, is prohibited without the written permission of the proprietor.
 Property of c BERG ELECTRONICS.
 Copyright BERG ELECTRONICS by

Tous droits strictement reserves. Reproduction ou communication a des tiers int sous quelque forme que ce soit sans autorisation ecrite du proprietaire.
 proprietaire de c BERG ELECTRONICS.
 Droits de reproduction BERG ELECTRONICS by

PRODUCT NO	POS NOS WITH CONTACTS	HOUSING MATERIAL	CONTACT PLATING
66011-001/-001LF	2,3,4,5	SUPER TOUGH NYLON UL 94V-0 GRAY	.76u/30u *AU OVER 2.5u/100u *NI
-002/-002LF	ALL		
-003/-003LF	2 & 5		
-004/-004LF	3 & 4	SUPER TOUGH NYLON UL 94V-0 GRAY	
-005/-005LF	2,3,4,5	SUPER TOUGH NYLON UL 94V-0 BLACK	.76u/30u *AU OVER 2.5u/100u *NI
-006/-006LF	ALL	SUPER TOUGH NYLON UL 94V-0 GRAY	.76u/30u *GXT
-007/-007LF	2,3,4,5		.76u/30u *GXT
-008/-008LF	2,3,4,5		1.27u/50u *AU OVER 2.5u/100u *NI
-009/-009LF	ALL	SUPER TOUGH NYLON UL 94V-0 GRAY	0.15u/6u * GOLD FLASH
66011-010/-010LF	2,3,4,5	SUPER TOUGH NYLON UL 94V-0 BLACK	.76u/30u *GXT

LEAD FREE PRODUCT NO.

NOTES:

- FOR VISUAL, MECHANICAL AND FUNCTIONAL REQUIREMENTS SEE SPECIFICATION BUS-12-084.
- GOLD WIRE MATERIAL: PHOS BRONZE ALLOY. UNS-C51000, 135-150M PSI TENSILE PLATING: SEE TABLE
- DIMENSIONAL TOLERANCE: ±.25/±.010 AT BASE ±.64/±.025 AT TIP
- FOR ADDITIONAL APPLICATION AND MOUNTING INFORMATION SEE DRAWING TA-390.
- HOUSING MATERIAL: SEE TABLE.
- TEST METHOD PER UL-1863, SECTION 22.2
- THE PRODUCT MEETS EUROPEAN UNION DIRECTIVES AND OTHER COUNTRY REGULATIONS AS DESCRIBED IN GS-22-008.
- THE HOUSING WILL WITHSTAND EXPOSURE TO 260°C PEAK TEMPERATURE FOR 10 SECONDS IN A WAVE SOLDER APPLICATION WITH A 1.60mm MINIMUM THICK CIRCUIT BOARD.
- IF LF P/N PACKAGING MEETS GS-14-920 SPECIFICATION.

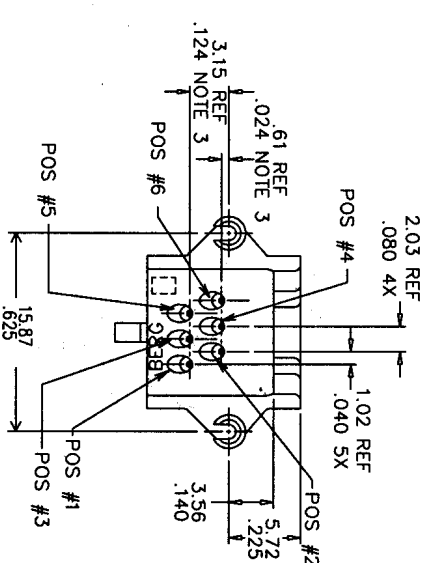
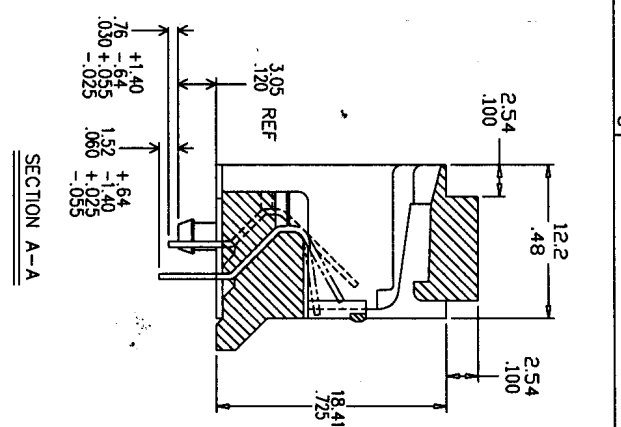
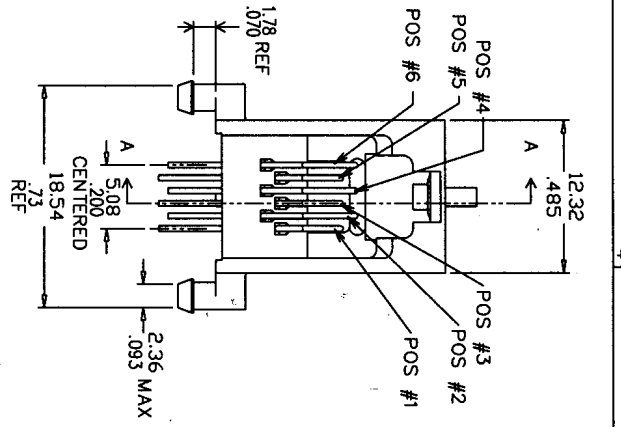

rev. sc'n no.	dr.	date	tolerance unless otherwise specified	CUSTOMER COPY	projection	title	product family	code
1		06/01/87	0 ± 0.25			MOD JACK ASSY	(623 PCB)	TMN
2		08/12/88	.00 ± 0.13					
3		10/19/88	.000 ± 0.05					
4		04/12/89	± .2					
5		06/01/87						
6		06/01/87						
7		06/01/87						
8		06/01/87						
9		06/01/87						
10		06/01/87						
11		06/01/87						
12		06/01/87						
13		06/01/87						
14		06/01/87						
15		06/01/87						
16		06/01/87						
17		06/01/87						
18		06/01/87						
19		06/01/87						
20		06/01/87						
21		06/01/87						
22		06/01/87						
23		06/01/87						
24		06/01/87						
25		06/01/87						
26		06/01/87						
27		06/01/87						
28		06/01/87						
29		06/01/87						
30		06/01/87						
31		06/01/87						
32		06/01/87						
33		06/01/87						
34		06/01/87						
35		06/01/87						
36		06/01/87						
37		06/01/87						
38		06/01/87						
39		06/01/87						
40		06/01/87						
41		06/01/87						
42		06/01/87						
43		06/01/87						
44		06/01/87						
45		06/01/87						
46		06/01/87						
47		06/01/87						
48		06/01/87						
49		06/01/87						
50		06/01/87						
51		06/01/87						
52		06/01/87						
53		06/01/87						
54		06/01/87						
55		06/01/87						
56		06/01/87						
57		06/01/87						
58		06/01/87						
59		06/01/87						
60		06/01/87						
61		06/01/87						
62		06/01/87						
63		06/01/87						
64		06/01/87						
65		06/01/87						
66		06/01/87						
67		06/01/87						
68		06/01/87						
69		06/01/87						
70		06/01/87						
71		06/01/87						
72		06/01/87						
73		06/01/87						
74		06/01/87						
75		06/01/87						
76		06/01/87						
77		06/01/87						
78		06/01/87						
79		06/01/87						
80		06/01/87						
81		06/01/87						
82		06/01/87						
83		06/01/87						
84		06/01/87						
85		06/01/87						
86		06/01/87						
87		06/01/87						
88		06/01/87						
89		06/01/87						
90		06/01/87						
91		06/01/87						
92		06/01/87						
93		06/01/87						
94		06/01/87						
95		06/01/87						
96		06/01/87						
97		06/01/87						
98		06/01/87						
99		06/01/87						
100		06/01/87						