

## Excellent Integrated System Limited

Stocking Distributor

Click to view price, real time Inventory, Delivery & Lifecycle Information:

[Industrial Fiber Optics, Inc.](#)  
[IF-D96F](#)

For any questions, you can email us directly:

[sales@integrated-circuit.com](mailto:sales@integrated-circuit.com)

# Plastic Fiber Optic Photologic Detector IF D96F

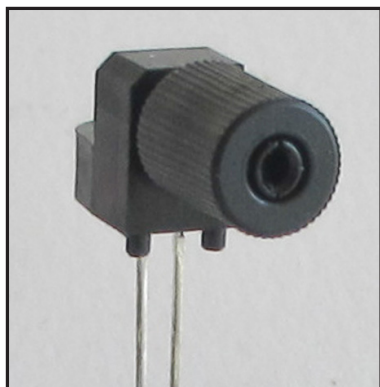

## APPLICATIONS

- ▶ Digital Data Links
- ▶ PC-to-Peripheral Links
- ▶ Process Control
- ▶ Digitized Audio
- ▶ Motor Controller Triggering
- ▶ Intra-System Links: Board-to-Board, Rack-to-Rack
- ▶ Medical Instruments
- ▶ Automotive Electronics
- ▶ Robotics Communications
- ▶ EMC/EMI Signal Isolation

## DESCRIPTION

The IF-D96F is a medium-speed photologic detector housed in a “connector-less” style plastic fiber optic package. The detector contains an IC with a photodiode, linear amplifier, voltage comparator, and Schmitt trigger logic circuit. The IF-D96F features an inverted open-collector Schottky transistor output (active low). The device can drive up to 5 TTL loads over output (pull-up) voltages ranging from 4.5 to 15 Volts. Optimized for visible wavelengths of 600 to 780 nm. The detector package features an internal micro-lens and a precision-molded PBT housing to ensure efficient optical coupling with standard 1000 μm core plastic fiber cable.

## APPLICATION HIGHLIGHTS

The IF-D96F is suitable for digital data links at rates up to 5 Mbps. A Schmitt trigger improves noise immunity and TTL/CMOS logic compatibility greatly simplifies interfacing with existing digital circuits. An enhanced internal electrical architecture ensures stable operation and wide dynamic range. The integrated design of the IF-D96F provides simple, cost-effective implementation in a variety of digital applications.

## FEATURES

- ◆ High Optical Sensitivity
- ◆ Mates with Standard 1000 μm Core Jacketed Plastic Fiber Optic Cable
- ◆ No Optical Design Required
- ◆ Inexpensive Plastic Connector Housing
- ◆ Internal Micro-Lens for Efficient Optical Coupling
- ◆ Connector-Less Fiber Termination
- ◆ Light-Tight Housing Provides Interference-Free Transmission
- ◆ Open Collector Output
- ◆ RoHS Compliant

## MAXIMUM RATINGS

(T<sub>A</sub> = 25°C)  
 Operating and Storage Temperature Range (T<sub>OP</sub>, T<sub>STG</sub>).....-40° to 85°C  
 Soldering Temperature (2mm from case bottom) (T<sub>S</sub>) t ≤ 5 s.....240°C  
 Supply Voltage, (V<sub>S</sub>) .....-5 to 15 V  
 Voltage at Output lead .....-5 to 15 V  
 Sinking Current, DC (I<sub>C</sub>) .....25 mA  
 Open Collector Power Dissipation (P<sub>O</sub>) T<sub>A</sub>=25°C .....80 mW  
 De-rate Above 25°C ...1.33 mW/°C

## CHARACTERISTICS (T<sub>A</sub>=25°C) V<sub>CC</sub> = 4.75 TO 5.25 V unless otherwise specified

Parameter	Symbol	Min.	Typ.	Max.	Unit
Peak Sensitivity	λ <sub>PEAK</sub>	-	700	-	nm
Spectral Sensitivity (S=80% of S <sub>MAX</sub> )	Δλ	600	-	780	nm
Recommended Operating Voltage	V <sub>CC</sub>	4.25	-	15.0	V
High Level Supply Current V <sub>CC</sub> =5.25 V *	I <sub>CCH</sub>	-	3.5	6	mA
Low Level Supply Current V <sub>CC</sub> =5.25 V *	I <sub>CCL</sub>	-	12	14.5	mA
Light Level to Trigger (R <sub>L</sub> =1 kΩ λ=660 nm)	E <sub>r</sub> (+)	-	7 -21.6	-	μW dBm
Light Level to Not Trigger (λ=660 nm)	E <sub>r</sub> (-)	-	0.1 -40	-	μW dBm
High Level Output Current V <sub>OH</sub> = 15 V	I <sub>OH</sub>	-	5	100	μA
Low Level Output Voltage (I <sub>OL</sub> = 8 mA)	V <sub>OL</sub>	-	0.1	0.5	V
Propagation Delay, Low-High (f= 100.0 kHz, R <sub>L</sub> = 5 TTL Loads)	t <sub>PLH</sub>	-	<250	-	ns
Propagation Delay, High-Low (f= 100.0 kHz, R= 5 TTL Loads)	t <sub>PHL</sub>	-	<100	-	ns

\* Load = 620 Ohms

**CAUTION:** The IF D96F is ESD sensitive. To minimize risk of damage observe appropriate precautions during handling and processing.

# IF D96F Plastic Fiber Optic Photologic Detector

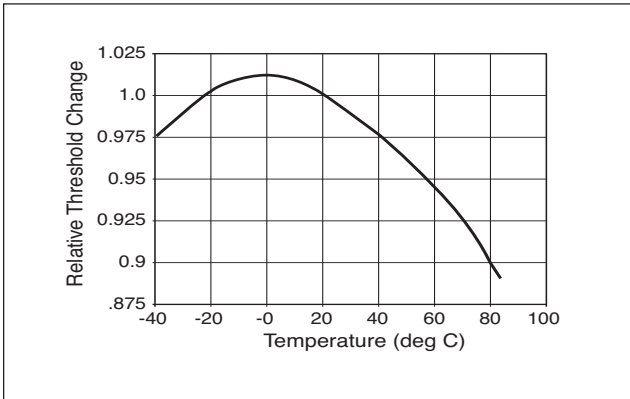

FIGURE 1. Normalized threshold irradiance vs. amb. temp.

## FIBER TERMINATION INSTRUCTIONS

1. Cut off the ends of the optical fiber with a single-edge razor blade or sharp knife. Try to obtain a precise 90-degree angle (square).
2. Insert the fiber through the locking nut and into the connector until the core tip seats against the internal micro-lens.
3. Screw the connector locking nut down to a snug fit, locking the fiber in place.

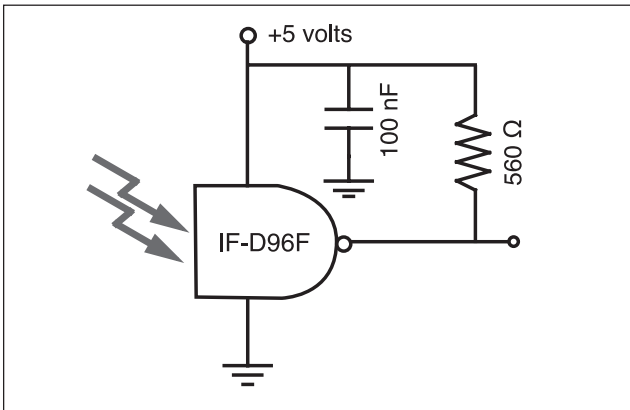

FIGURE 2. Typical operating circuit.

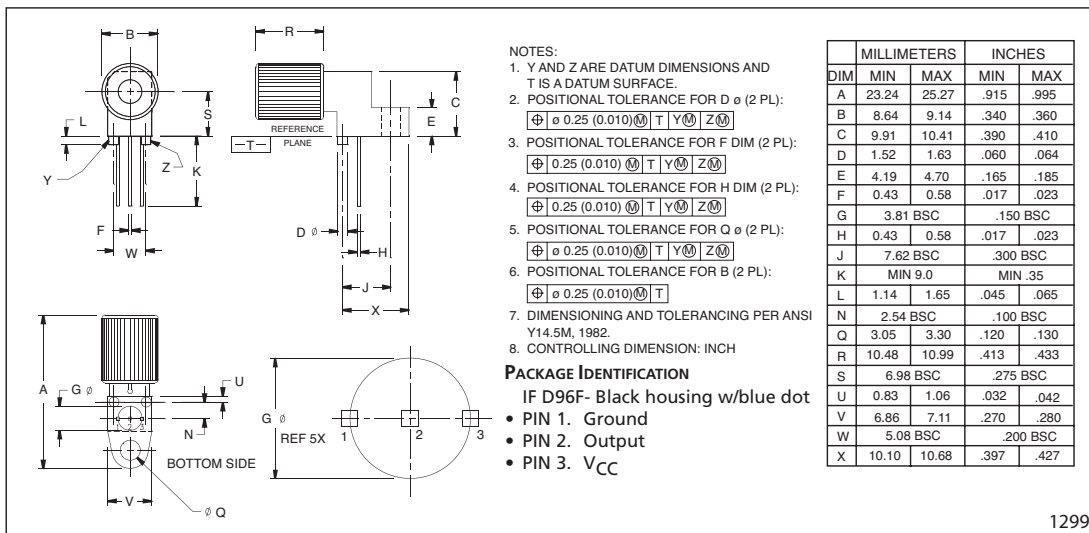

FIGURE 3. Case outline. Specifications are believed to be accurate but are subject to change. Industrial Fiber Optics assumes no responsibility for the consequences of using the information provided beyond replacement warranty for products not meeting stated specifications. Industrial Fiber Optics products are not authorized for use in life support applications without written approval from the President of Industrial Fiber Optics Corporation.

**CAUTION:**

- To avoid degraded device life due to package stress, do not bend or form leads outside the orientation shown on drawing.
- Ensure that solder flux does not migrate into the device and block the optical path, degrading the performance.
- If washing the device, liquid may become trapped in the part cavity. Ensure that all potentially corrosive materials are flushed out of the device.