

Excellent Integrated System Limited

Stocking Distributor

Click to view price, real time Inventory, Delivery & Lifecycle Information:

[NMB Technologies Corp.](#)
[FBA08T12L](#)

For any questions, you can email us directly:

sales@integrated-circuit.com

FBA08T (80mm Thin)

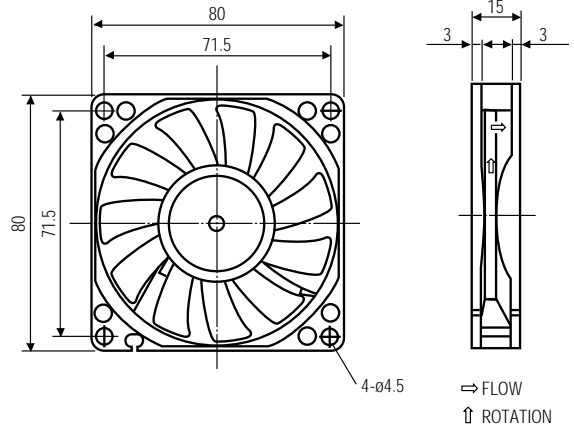

CUT OUT

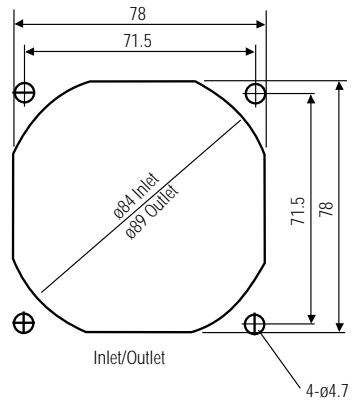

Features

- Operating Temperature: -10°C — +70°C (65% RH)
- Storage Temperature: -40°C — +75°C (65% RH)
- Bearing Type: Hydro Wave
- Aerodynamic blade and venturi design
- Locked rotor protection and auto-start function
- Lower circuit noise by new IC
- Optional third wire lead signal (Locked rotor alarm sensor)

Basic Data (nominal at room temperature)

	Rated Voltage (V)	Operating Voltage (V)	Rated Current (mA)	Rated Input (W)	Nominal Speed (r/min)	Maximum Air Flow		Maximum Air Pressure		Noise (dB-A)
						(m3/min)	(CFM)	(mmH2O)	(Pa)	
FBA08T12L	12	7—13.8	79	0.95	2000	0.62	21.9	1.55	15.2	23.0
FBA08T12H	12	7—13.8	200	2.40	3100	0.95	33.5	3.20	31.4	34.0
FBA08T24L	24	14—27.6	47	1.13	2000	0.62	21.9	1.55	15.2	23.0
FBA08T24H	24	14—27.6	110	2.64	3100	0.95	33.5	3.20	31.4	34.0

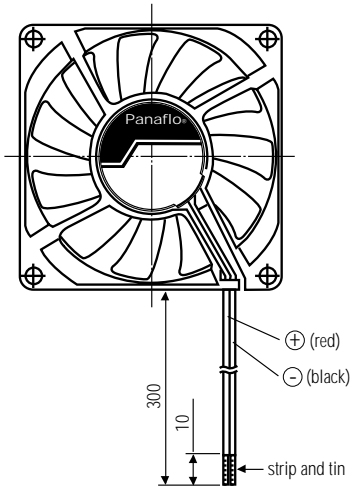

All dimensions in mm.

Lead Wire

All lead wires are 325 mm in length \pm 15 mm.

Housing and Fan Blade: Plastic (PET, PBT, ABS)

Size

80.0 x 80.0 x 15.0
(3.15 x 3.15 x 0.59)

Weight

70 grams (2.47 ounces)

Case Quantity

100 per box

Conversion Factors

1 mm H₂O = 9.8 PA

1 m³/min = 35.313 CFM

FBA08T (80mm Thin)

Characteristics

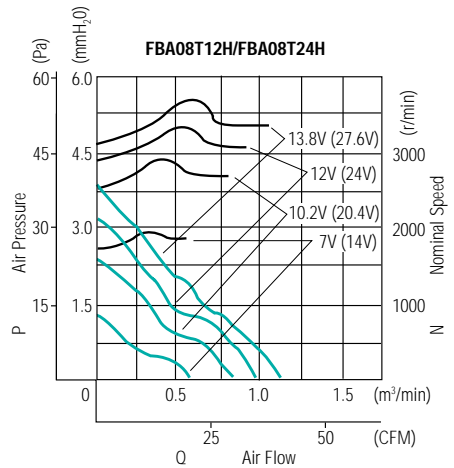
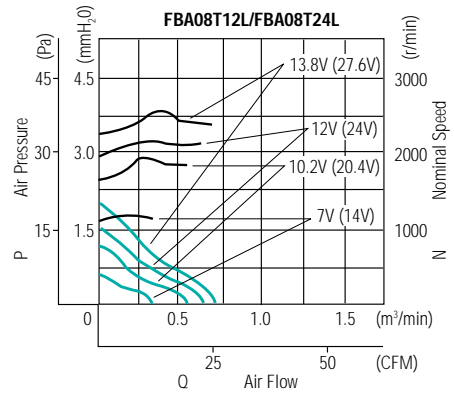

— P—Q
— N—Q