

Excellent Integrated System Limited

Stocking Distributor

Click to view price, real time Inventory, Delivery & Lifecycle Information:

[STMicroelectronics](#)
[74VHC16373TTR](#)

For any questions, you can email us directly:

sales@integrated-circuit.com



74VHC16373

16-BIT D-TYPE LATCH WITH 3-STATE OUTPUTS NON INVERTING

- **HIGH SPEED:**
 $t_{PD} = 5.0 \text{ ns (TYP.) at } V_{CC} = 5V$
- **LOW POWER DISSIPATION:**
 $I_{CC} = 4 \mu A \text{ (MAX.) at } T_A = 25^\circ C$
- **HIGH NOISE IMMUNITY:**
 $V_{NIH} = V_{NIL} = 28\% V_{CC} \text{ (MIN.)}$
- **POWER DOWN PROTECTION ON INPUTS**
- **SYMMETRICAL OUTPUT IMPEDANCE:**
 $|I_{OH}| = I_{OL} = 8 \text{ mA (MIN)}$
- **BALANCED PROPAGATION DELAYS:**
 $t_{PLH} \approx t_{PHL}$
- **OPERATING VOLTAGE RANGE:**
 $V_{CC(OPR)} = 2V \text{ to } 5.5V$
- **PIN AND FUNCTION COMPATIBLE WITH 74 SERIES 16373**
- **IMPROVED LATCH-UP IMMUNITY**
- **LOW NOISE: $V_{OLP} = 0.9V \text{ (MAX.)}$**



ORDER CODES

PACKAGE	TUBE	T & R
TSSOP		74VHC16373TTR

PIN CONNECTION

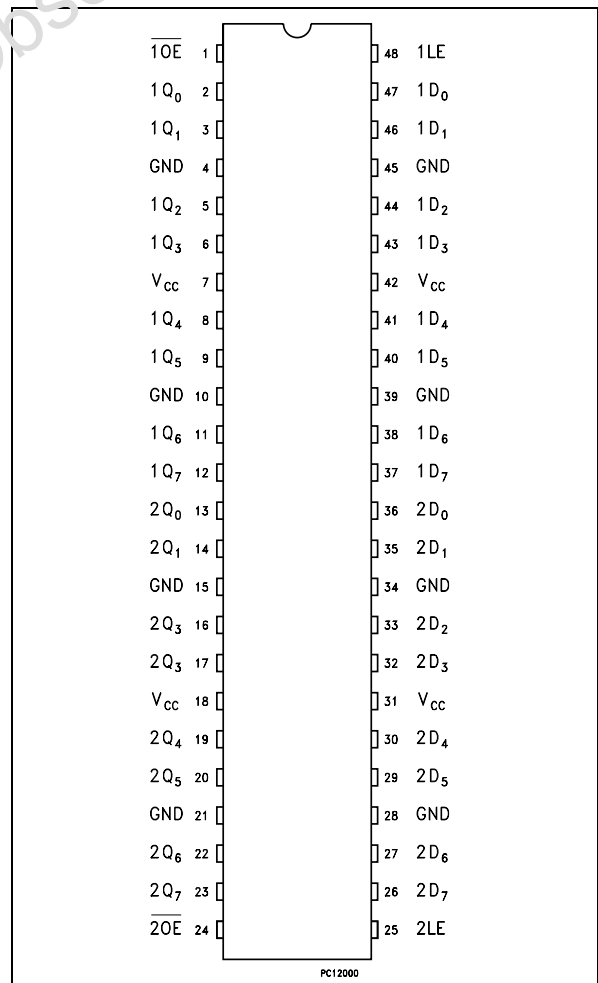

DESCRIPTION

The 74VHC16373 is an advanced high-speed CMOS 16 BIT D-TYPE LATCH with 3 STATE OUTPUTS NON INVERTING fabricated with sub-micron silicon gate and double-layer metal wiring CMOS technology.

These 16 bit D-TYPE latches are byte controlled by two latch enable inputs (nLE) and two output enable inputs (nOE).

While the nLE input is held at a high level, the nQ outputs will follow the data (D) inputs.

When the nLE is taken LOW, the nQ outputs will be latched at the logic level of D data inputs.

When the (nOE) input is low, the nQ outputs will be in a normal logic state (high or low logic level); when nOE is at high level, the outputs will be in a high impedance state.

Power down protection is provided on all inputs and 0 to 7V can be accepted on inputs with no regard to the supply voltage. This device can be used to interface 5V to 3V.

All inputs and outputs are equipped with protection circuits against static discharge, giving them 2KV ESD immunity and transient excess voltage.

74VHC16373

INPUT EQUIVALENT CIRCUIT

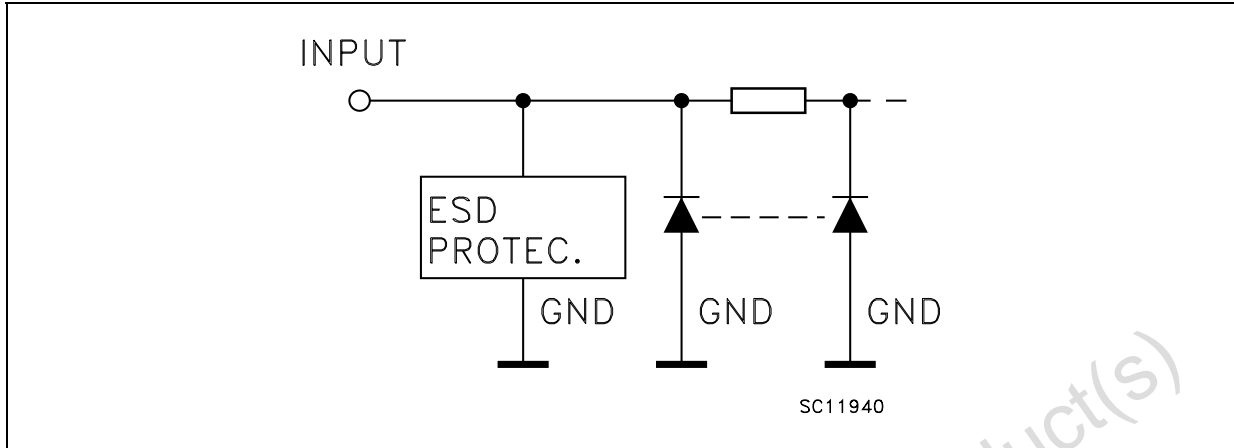

PIN DESCRIPTION

PIN No	SYMBOL	NAME AND FUNCTION
1	1OE	3 State Output Enable Input (Active LOW)
2, 3, 5, 6, 8, 9, 11, 12	1Q0 to 1Q7	3-State Outputs
13, 14, 16, 17, 19, 20, 22, 23	2Q0 to 2Q7	3-State Outputs
24	2OE	3 State Output Enable Input (Active LOW)
25	2LE	Latch Enable Input
36, 35, 33, 32, 30, 29, 27, 26	2D0 to 2D7	Data Inputs
47, 46, 44, 43, 41, 40, 38, 37	1D0 to 1D7	Data Inputs
48	LE	Latch Enable Input
4, 10, 15, 21, 28, 34, 39, 45	GND	Ground (0V)
7, 18, 31, 42	V _{CC}	Positive Supply Voltage

IEC LOGIC SYMBOLS

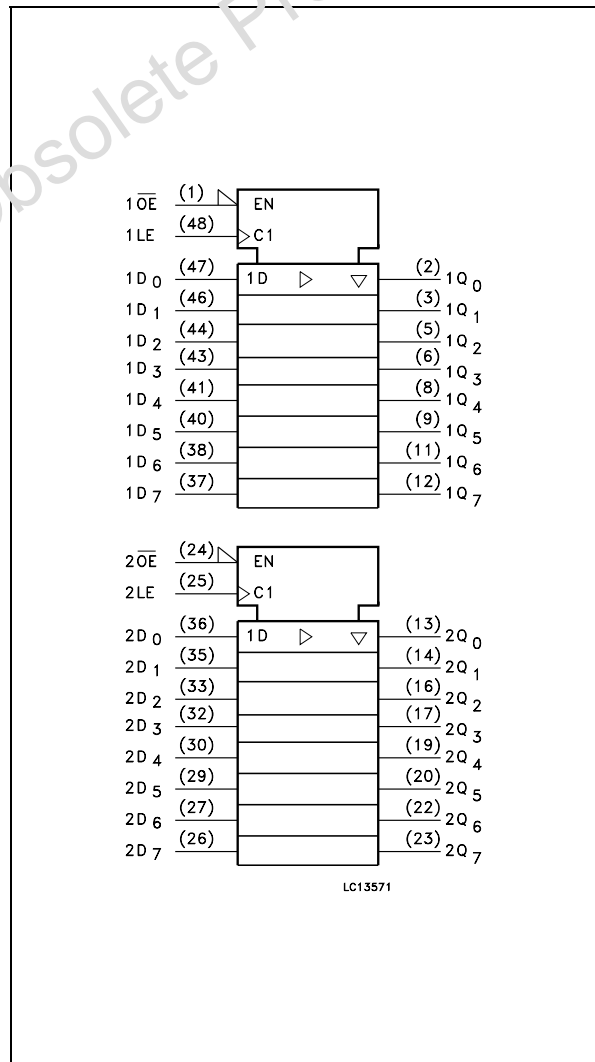

TRUTH TABLE

INPUTS			OUTPUT
OE	LE	D	Q
H	X	X	Z
L	L	X	NO CHANGE *
L	H	L	L
L	H	H	H

X : Don't Care
 Z : High Impedance
 * : Q outputs are latched at the time when the LE input is taken low logic level.

74VHC16373

LOGIC DIAGRAM

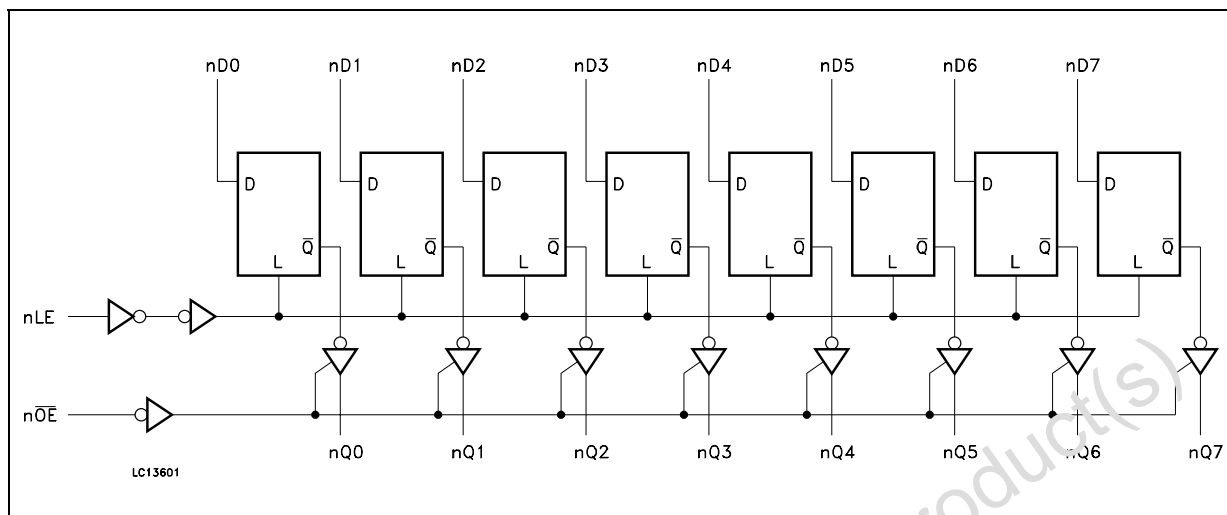

This logic diagram has not to be used to estimate propagation delays

ABSOLUTE MAXIMUM RATINGS

Symbol	Parameter	Value	Unit
V_{CC}	Supply Voltage	-0.5 to +7.0	V
V_I	DC Input Voltage	-0.5 to +7.0	V
V_O	DC Output Voltage	-0.5 to $V_{CC} + 0.5$	V
I_{IK}	DC Input Diode Current	-20	mA
I_{OK}	DC Output Diode Current	± 20	mA
I_O	DC Output Current	± 25	mA
I_{CC} or I_{GND}	DC V_{CC} or Ground Current	± 75	mA
T_{stg}	Storage Temperature	-65 to +150	$^{\circ}C$
T_L	Lead Temperature (10 sec)	300	$^{\circ}C$

Absolute Maximum Ratings are those values beyond which damage to the device may occur. Functional operation under these conditions is not implied

RECOMMENDED OPERATING CONDITIONS

Symbol	Parameter	Value	Unit
V_{CC}	Supply Voltage	2 to 5.5	V
V_I	Input Voltage	0 to 5.5	V
V_O	Output Voltage	0 to V_{CC}	V
T_{op}	Operating Temperature	-55 to 125	$^{\circ}C$
dt/dv	Input Rise and Fall Time (note 1) ($V_{CC} = 3.3 \pm 0.3V$) ($V_{CC} = 5.0 \pm 0.5V$)	0 to 100 0 to 20	ns/V

1) V_{IN} from 30% to 70% of V_{CC}

74VHC16373

DC SPECIFICATIONS

Symbol	Parameter	Test Condition		Value						Unit	
		V _{CC} (V)		T _A = 25°C			-40 to 85°C		-55 to 125°C		
				Min.	Typ.	Max.	Min.	Max.	Min.		Max.
V _{IH}	High Level Input Voltage	2.0		1.5			1.5		1.5		V
		3.0 to 5.5		0.7V _{CC}			0.7V _{CC}		0.7V _{CC}		
V _{IL}	Low Level Input Voltage	2.0				0.5		0.5		0.5	V
		3.0 to 5.5				0.3V _{CC}		0.3V _{CC}		0.3V _{CC}	
V _{OH}	High Level Output Voltage	2.0	I _O =-50 μA	1.9	2.0		1.9		1.9		V
		3.0	I _O =-50 μA	2.9	3.0		2.9		2.9		
		4.5	I _O =-50 μA	4.4	4.5		4.4		4.4		
		3.0	I _O =-4 mA	2.58			2.48		2.4		
		4.5	I _O =-8 mA	3.94			3.8		3.7		
V _{OL}	Low Level Output Voltage	2.0	I _O =50 μA		0.0	0.1		0.1		0.1	V
		3.0	I _O =50 μA		0.0	0.1		0.1		0.1	
		4.5	I _O =50 μA		0.0	0.1		0.1		0.1	
		3.0	I _O =4 mA			0.36		0.44		0.55	
		4.5	I _O =8 mA			0.36		0.44		0.55	
I _{OZ}	High Impedance Output Leakage Current	5.5	V _I = V _{IH} or V _{IL} V _O = V _{CC} or GND			±0.25		±2.5		±5	μA
I _I	Input Leakage Current	0 to 5.5	V _I = 5.5V or GND			±0.1		±1		±1	μA
I _{CC}	Quiescent Supply Current	5.5	V _I = V _{CC} or GND			4		40		40	μA

74VHC16373

AC ELECTRICAL CHARACTERISTICS (Input $t_r = t_f = 3\text{ns}$)

Symbol	Parameter	Test Condition		Value								Unit
		V_{CC} (V)	C_L (pF)	$T_A = 25^\circ\text{C}$			-40 to 85°C		-55 to 125°C			
				Min.	Typ.	Max.	Min.	Max.	Min.	Max.		
t_{PLH} t_{PHL}	Propagation Delay Time LE to Qn	3.3 ^(*)	15		5.5	13	1	15	1	15	ns	
		3.3 ^(*)	50		7	14.5	1	16.5	1	16.5		
		5.0 ^(**)	15		3.6	8.5	1	9.5	1	9.5		
		5.0 ^(**)	50		5	9.5	1	10.5	1	10.5		
t_{PLH} t_{PHL}	Propagation Delay Time Dn to Qn	3.3 ^(*)	15		5.5	13	1	15	1	15	ns	
		3.3 ^(*)	50		7.5	14	1	16	1	16		
		5.0 ^(**)	15		4	8.2	1	9.5	1	9.5		
		5.0 ^(**)	50		5	9.2	1	10.5	1	10.5		
t_{PZL} t_{PZH}	Output Enable Time	3.3 ^(*)	15		5.2	13	1	15	1	15	ns	
		3.3 ^(*)	50		7.6	14.9	1	16	1	16		
		5.0 ^(**)	15		4	9.1	1	10	1	10	ns	
		5.0 ^(**)	50		5	10.1	1	11.5	1	11.5		
t_{PLZ} t_{PHZ}	Output Disable Time	3.3 ^(*)	50		9	15.5	1	17	1	17	ns	
		5.0 ^(**)	50		8	10.5	1	11.5	1	11.5		
t_w	Pulse Width (LE) HIGH	3.3 ^(*)			5			5		5	ns	
		5.0 ^(**)			5			5		5		
t_s	Setup Time Dn to LE HIGH or LOW	3.3 ^(*)			4			4		4	ns	
		5.0 ^(**)			4			4		4		
t_h	Hold Time Dn to LE HIGH or LOW	3.3 ^(*)			1			1		1	ns	
		5.0 ^(**)			1			1		1		
t_{OSLH} t_{OSHL}	Output to Output Skew time (note 1)	3.3 ^(*)	50			1.5		1.5		1.5	ns	
		5.0 ^(**)	50			1		1		1		

(*) Voltage range is $2.3\text{V} \pm 0.3\text{V}$

(**) Voltage range is $5.0\text{V} \pm 0.5\text{V}$

Note 1 : Parameter guaranteed by design. $t_{soLH} = |t_{pLHm} - t_{pLHn}|$; $t_{soHL} = |t_{pHLm} - t_{pHLn}|$

CAPACITIVE CHARACTERISTICS

Symbol	Parameter	Test Condition		Value								Unit
		V_{CC} (V)		$T_A = 25^\circ\text{C}$			-40 to 85°C		-55 to 125°C			
				Min.	Typ.	Max.	Min.	Max.	Min.	Max.		
C_{IN}	Input Capacitance				2.5	10		10		10	pF	
C_{OUT}	Output Capacitance				4						pF	
C_{PD}	Power Dissipation Capacitance (note 1)	5.0	$f_{IN} = 10\text{MHz}$		21						pF	

1) C_{PD} is defined as the value of the IC's internal equivalent capacitance which is calculated from the operating current consumption without load. (Refer to Test Circuit). Average operating current can be obtained by the following equation. $I_{CC(opr)} = C_{PD} \times V_{CC} \times f_{IN} + I_{CC}/n$ (per Latch)

74VHC16373

DYNAMIC SWITCHING CHARACTERISTICS

Symbol	Parameter	Test Condition		Value						Unit	
		V _{CC} (V)		T _A = 25°C			-40 to 85°C		-55 to 125°C		
				Min.	Typ.	Max.	Min.	Max.	Min.		Max.
V _{OLP}	Dynamic Low Voltage Quiet Output (note 1, 2)	5.0	C _L = 50 pF		0.6	0.9					V
V _{OLV}				-0.9	-0.6						
V _{IHD}	Dynamic High Voltage Input (note 1, 3)	5.0		3.5							V
V _{ILD}	Dynamic Low Voltage Input (note 1, 3)	5.0				1.5					V

1) Worst case package.

2) Max number of outputs defined as (n). Data inputs are driven 0V to 5.0V, (n-1) outputs switching and one output a GND.

3) Max number of data inputs (n) switching. (n-1) switching 0V to 5.0V. Inputs under test switching: 5.0V to threshold (V_{ILD}), 0V to threshold (V_{IHD}), f=1MHz.

TEST CIRCUIT

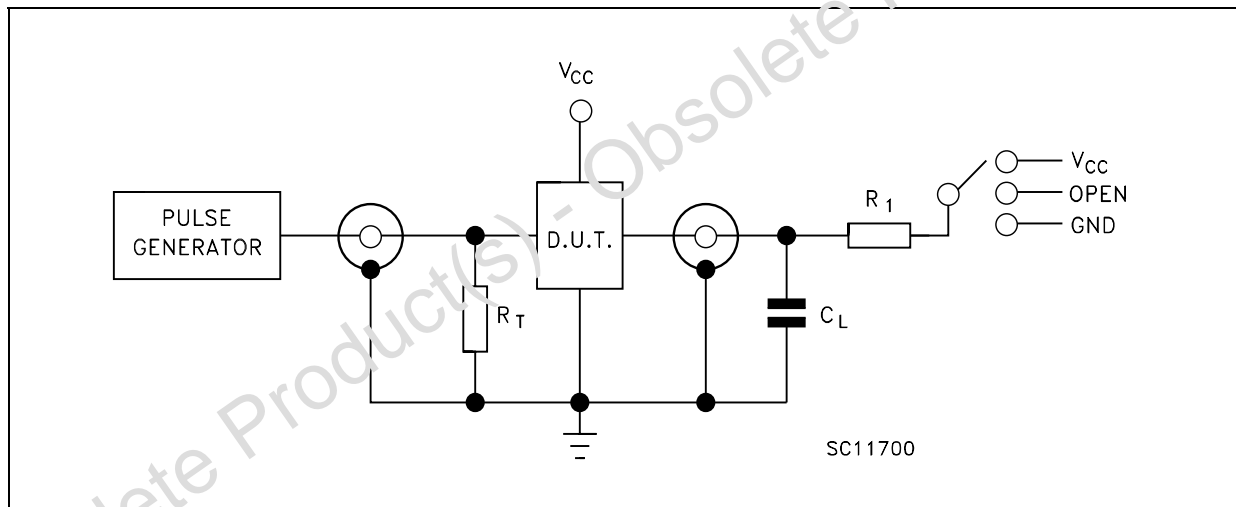

TEST	SWITCH
t _{pLH} , t _{pHL}	Open
t _{pZL} , t _{pLZ}	V _{CC}
t _{pZH} , t _{pHZ}	GND

C_L = 15/50 pF or equivalent (includes jig and probe capacitance)

R_L = R₁ = 1KΩ or equivalent

R_T = Z_{OUT} of pulse generator (typically 50Ω)

74VHC16373

WAVEFORM 1 : LE TO Qn PROPAGATION DELAYS, LE MINIMUM PULSE WIDTH, Dn TO LE SETUP AND HOLD TIMES (f=1MHz; 50% duty cycle)

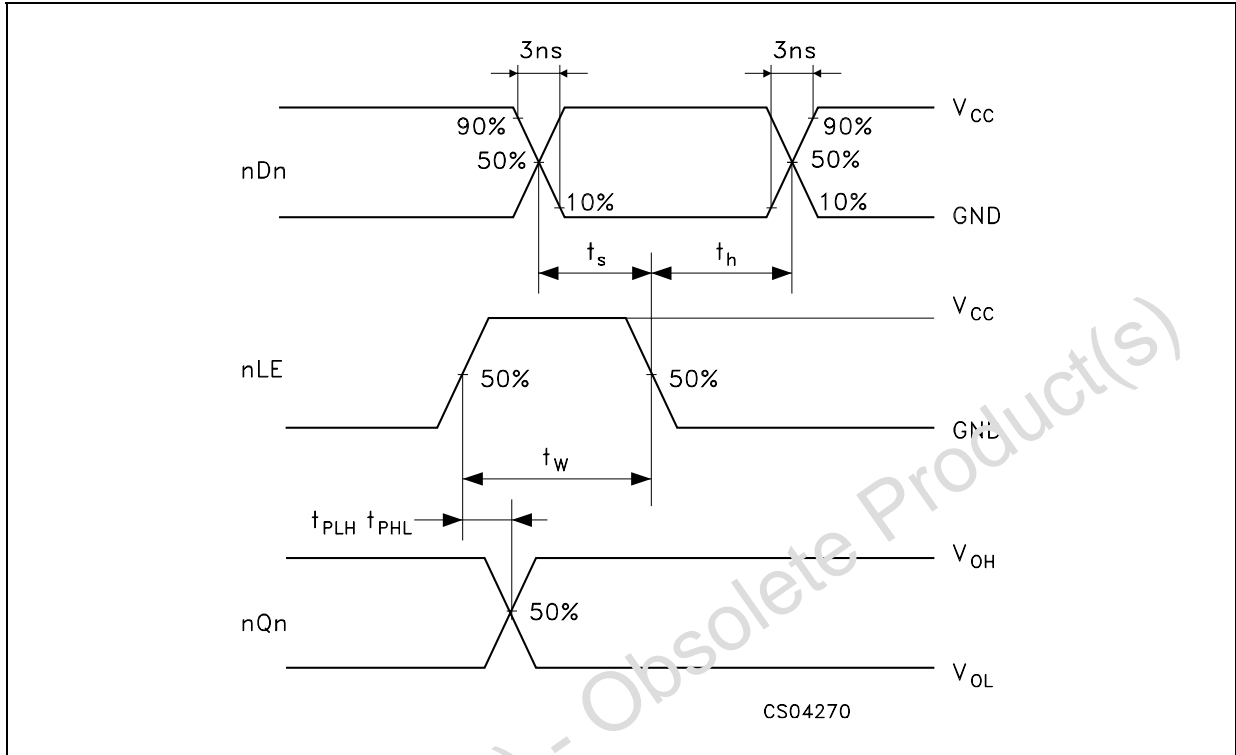

WAVEFORM 2: OUTPUT ENABLE AND DISABLE TIME (f=1MHz; 50% duty cycle)

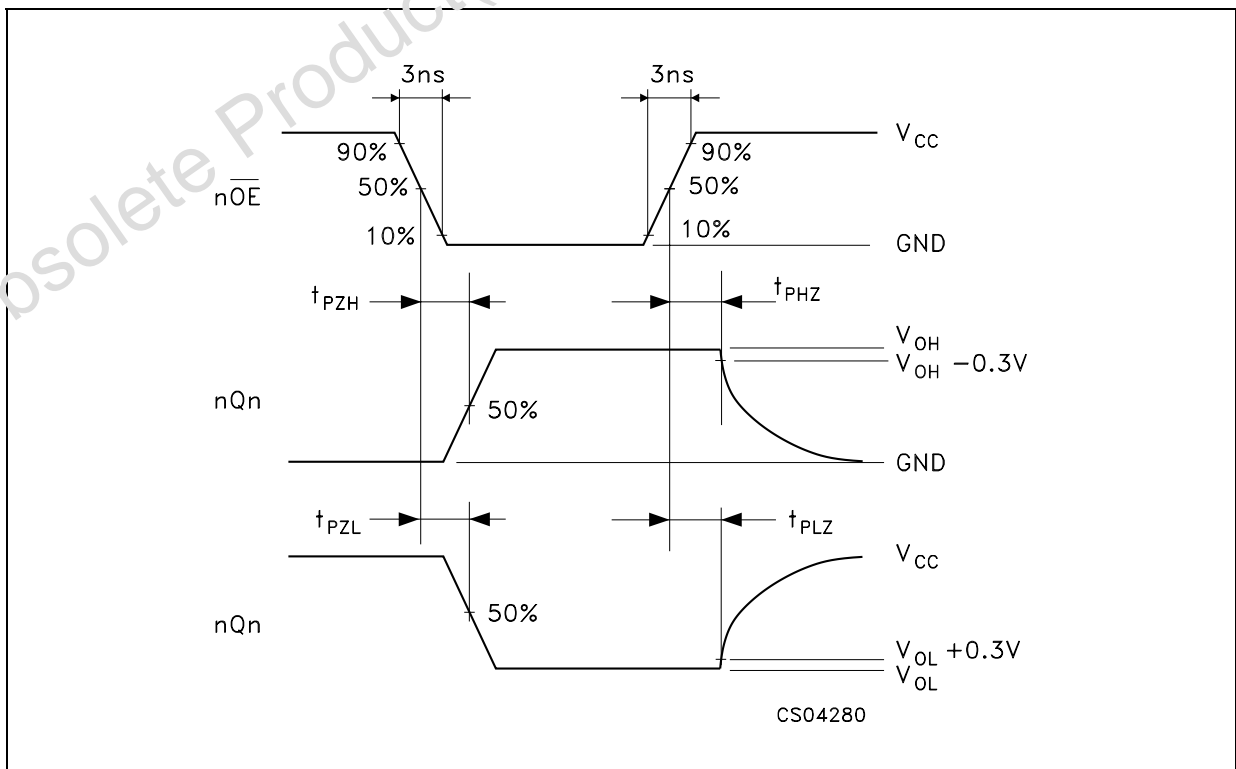

74VHC16373

WAVEFORM 3 : PROPAGATION DELAY TIME (f=1MHz; 50% duty cycle)

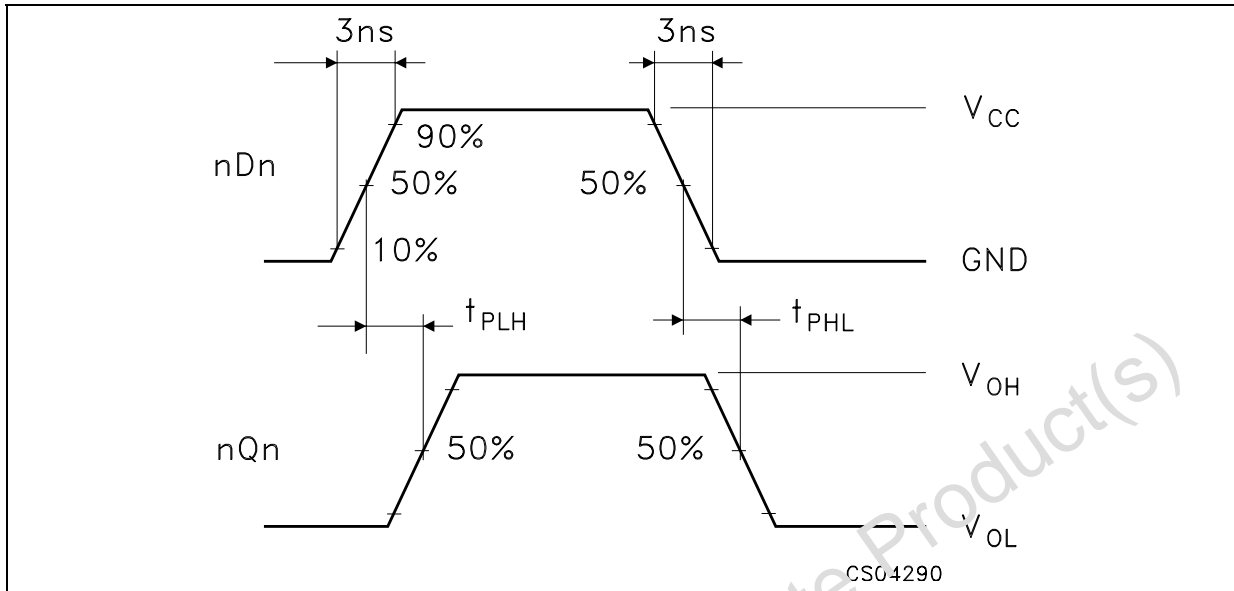

Obsolete Product(s) - Obsolete Product(s)

74VHC16373

TSSOP48 MECHANICAL DATA

DIM.	mm.			inch		
	MIN.	TYP	MAX.	MIN.	TYP.	MAX.
A			1.2			0.047
A1	0.05		0.15	0.002		0.006
A2		0.9			0.035	
b	0.17		0.27	0.0067		0.011
c	0.09		0.20	0.0035		0.0079
D	12.4		12.6	0.488		0.496
E		8.1 BSC			0.318 BSC	
E1	6.0		6.2	0.236		0.244
e		0.5 BSC			0.0197 BSC	
K	0°		8°	0°		8°
L	0.50		0.75	0.020		0.030

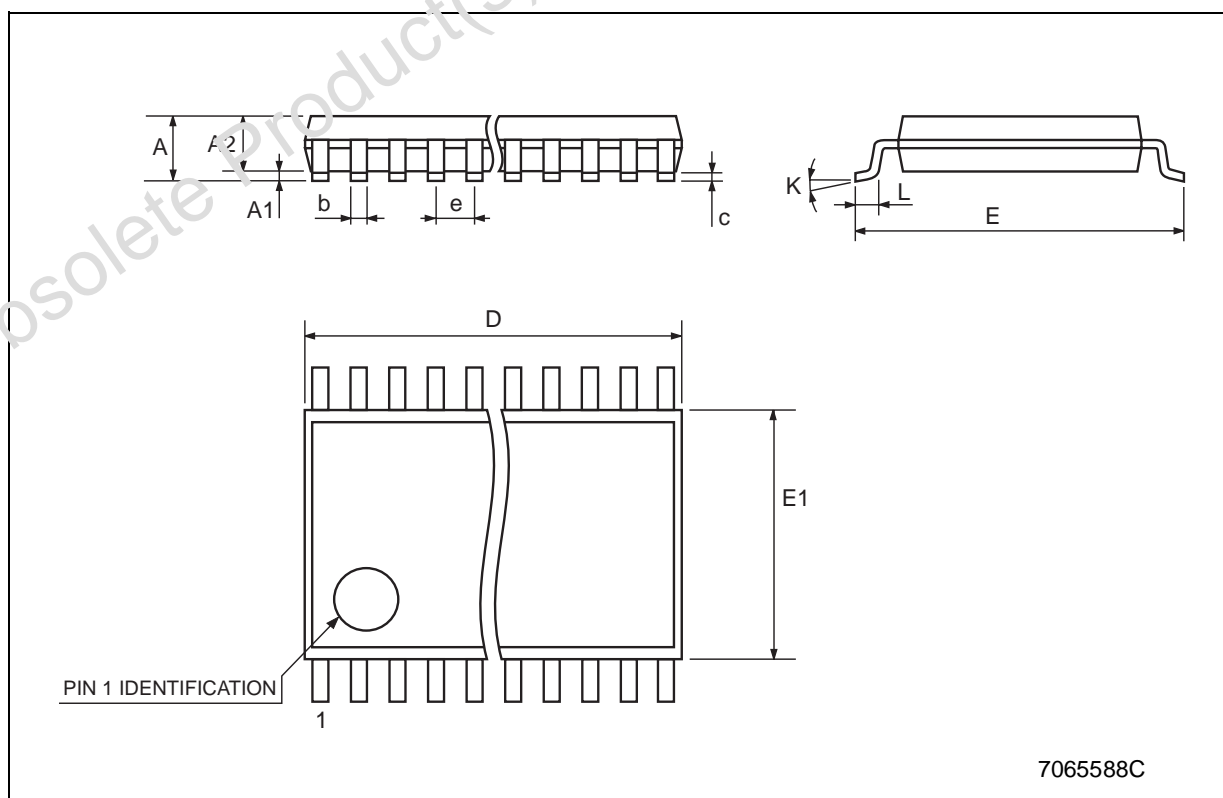

7065588C

74VHC16373

Tape & Reel TSSOP48 MECHANICAL DATA

DIM.	mm.			inch		
	MIN.	TYP	MAX.	MIN.	TYP.	MAX.
A			330			12.992
C	12.8		13.2	0.504		0.519
D	20.2			0.795		
N	60			2.362		
T			30.4			1.197
Ao	8.7		8.9	0.343		0.350
Bo	13.1		13.3	0.516		0.524
Ko	1.5		1.7	0.059		0.067
Po	3.9		4.1	0.153		0.161
P	11.9		12.1	0.468		0.476

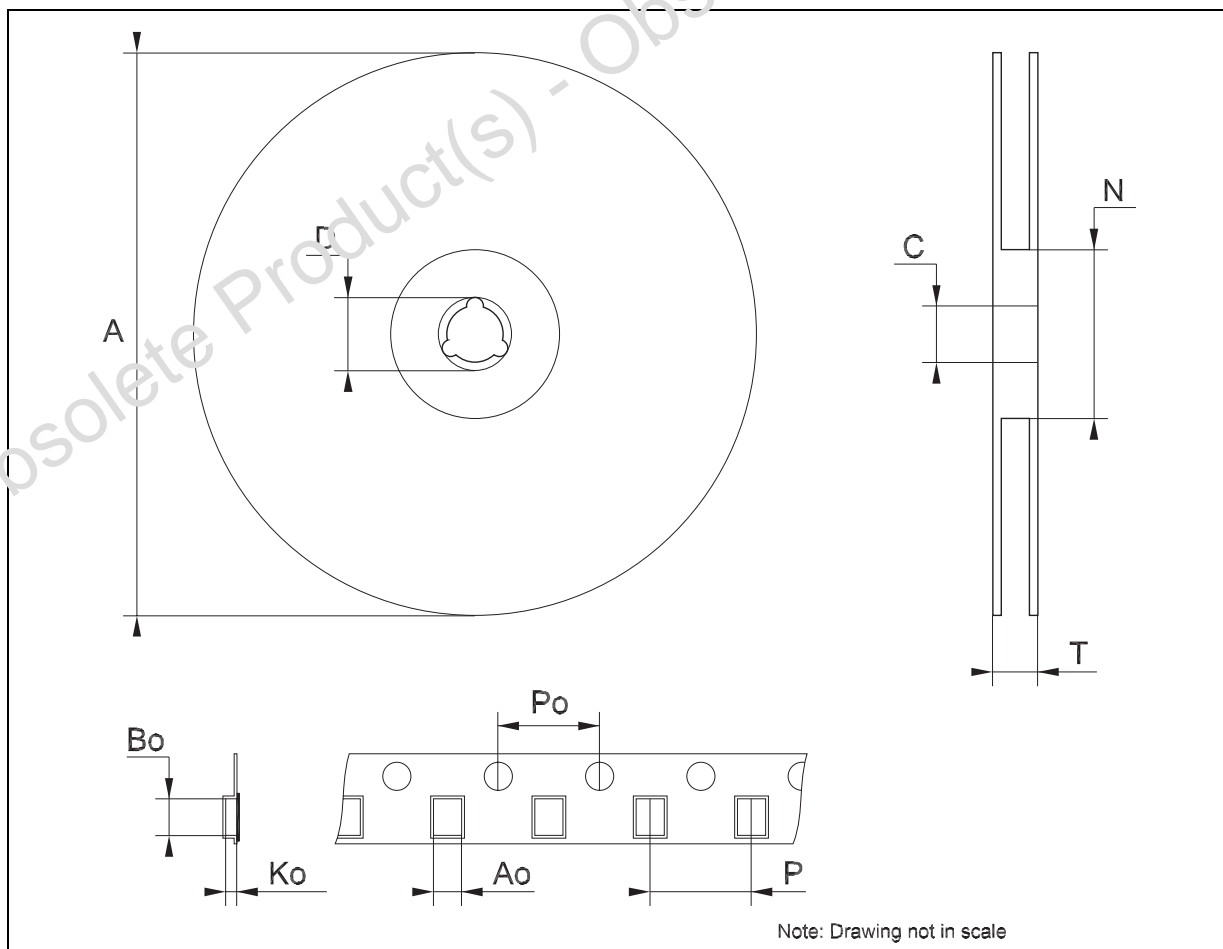

74VHC16373

Obsolete Product(s) - Obsolete Product(s)

Information furnished is believed to be accurate and reliable. However, STMicroelectronics assumes no responsibility for the consequences of use of such information nor for any infringement of patents or other rights of third parties which may result from its use. No license is granted by implication or otherwise under any patent or patent rights of STMicroelectronics. Specifications mentioned in this publication are subject to change without notice. This publication supersedes and replaces all information previously supplied. STMicroelectronics products are not authorized for use as critical components in life support devices or systems without express written approval of STMicroelectronics.

© The ST logo is a registered trademark of STMicroelectronics

© 2003 STMicroelectronics - Printed in Italy - All Rights Reserved
STMicroelectronics GROUP OF COMPANIES

Australia - Brazil - Canada - China - Finland - France - Germany - Hong Kong - India - Israel - Italy - Japan - Malaysia - Malta - Morocco
Singapore - Spain - Sweden - Switzerland - United Kingdom - United States.

© <http://www.st.com>