

Excellent Integrated System Limited

Stocking Distributor

Click to view price, real time Inventory, Delivery & Lifecycle Information:

[STMicroelectronics](#)
[TS512AIN](#)

For any questions, you can email us directly:

sales@integrated-circuit.com



TS512,A

PRECISION DUAL OPERATIONAL AMPLIFIER

- **LOW INPUT OFFSET VOLTAGE:**
500 μ V max.
- **LOW POWER CONSUMPTION**
- **SHORT CIRCUIT PROTECTION**
- **LOW DISTORTION, LOW NOISE**
- **HIGH GAIN-BANDWIDTH PRODUCT:**
3MHz
- **HIGH CHANNEL SEPARATION**
- **ESD INTERNAL PROTECTION**
- **LOW INPUT OFFSER CURRENT**

- **MACROMODEL INCLUDED IN THIS SPECIFICATION**

DESCRIPTION

The TS512 is a high performance dual operational amplifier with frequency and phase compensation built into the chip. The internal phase compensation allows stable operation as voltage follower in spite of its high gain-bandwidth products.

The circuit presents very stable electrical characteristics over the entire supply voltage range, and is particularly intended for professional and telecom applications (active filter, etc).

PIN CONNECTIONS (top view)

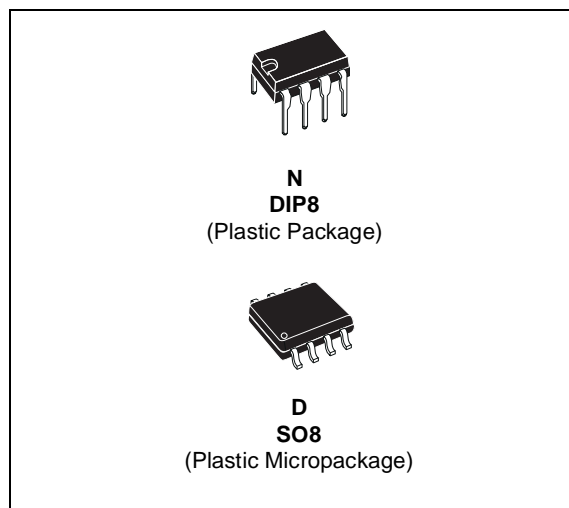
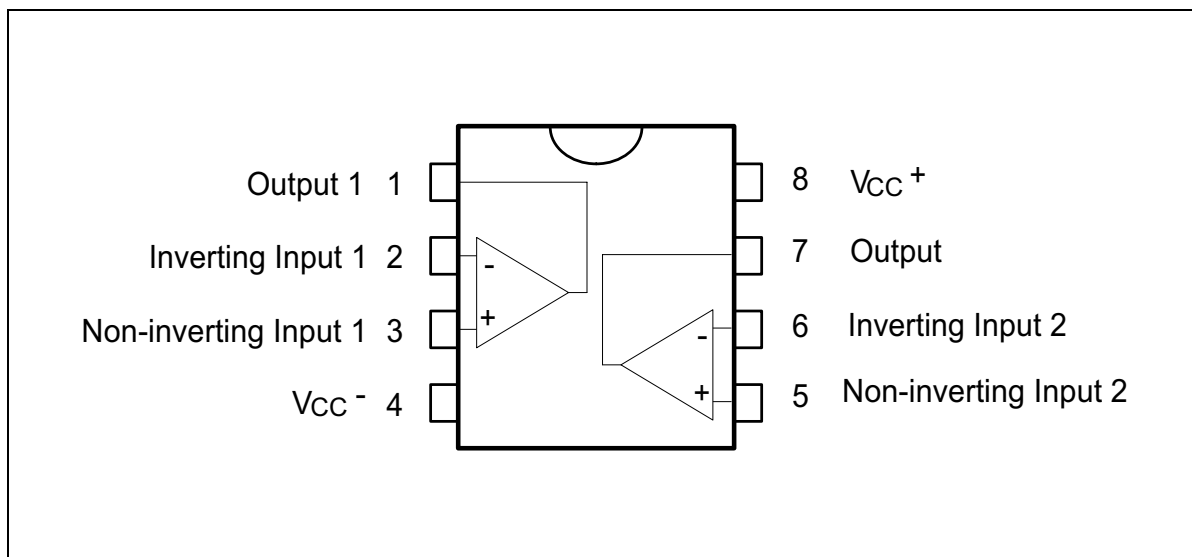

ORDER CODE

Part Number	Temperature Range	Package	
		N	D
TS512I	-40°C, +125°C	•	•
TS512AI	-40°C, +125°C	•	•

N = Dual in Line Package (DIP)
 D = Small Outline Package (SO) - also available in Tape & Reel (DT)

TS512, A

SCHEMATIC DIAGRAM (1/2 TS512)

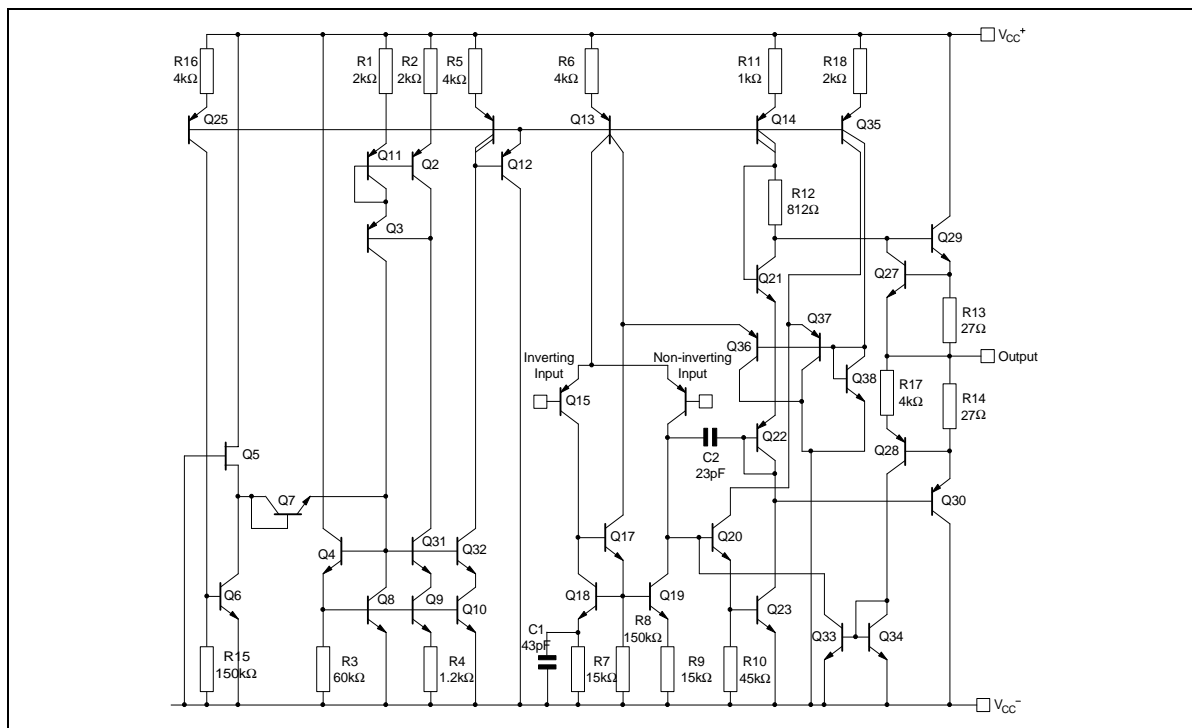

ABSOLUTE MAXIMUM RATINGS

Symbol	Parameter	Value	Unit
V_{CC}	Supply Voltage	± 18	V
V_i	Input Voltage	$\pm V_{CC}$	
V_{id}	Differential Input Voltage	$\pm(V_{CC} - 1)$	
T_{oper}	Operating Free-Air Temperature Range	-40 to +125	°C
P_{tot}	Power Dissipation at $T_{amb} = 70^\circ\text{C}^{1)}$	500	mW
T_j	Junction Temperature	+ 150	°C
T_{stg}	Storage Temperature Range	-65 to +150	°C

1. Power dissipation must be considered to ensure maximum junction temperature (T_j) is not exceeded.

ELECTRICAL CHARACTERISTICS
 $V_{CC} = \pm 15V$, $T_{amb} = 25^{\circ}C$ (unless otherwise specified)

Symbol	Parameter	Min.	Typ.	Max.	Unit
I_{cc}	Supply Current		0.7	1.2	mA
I_{ib}	Input Bias Current $T_{min} \leq T_{op} \leq T_{max}$		50	150 300	nA
R_i	Input Resistance, $f = 1kHz$		1		M Ω
V_{io}	Input Offset Voltage TS512 TS512A $T_{min} \leq T_{op} \leq T_{max}$ TS512 TS512A		0.5	2.5 0.5 3.5 1.5	mv
ΔV_{io}	Input Offset Voltage Drift $T_{min} \leq T_{op} \leq T_{max}$		2		$\mu V/^{\circ}C$
I_{io}	Input Offset Current $T_{min} \leq T_{op} \leq T_{max}$		5	20 40	nA
ΔI_{io}	Input Offset Current Drift $T_{min} \leq T_{op} \leq T_{max}$		0.08		$\frac{nA}{^{\circ}C}$
I_{os}	Output Short Circuit Current		23		mA
A_{vd}	Large Signal Voltage Gain $R_L = 2k\Omega$ $V_{CC} = \pm 15V$ $V_{CC} = \pm 4V$	90	100 95		dB
GBP	Gain-bandwidth Product, $f = 100kHz$	1.8	3		MHz
e_n	Equivalent Input Noise Voltage, $f = 1kHz$ $R_s = 50\Omega$ $R_s = 1k\Omega$ $R_s = 10k\Omega$		8 10 18		$\frac{nV}{\sqrt{Hz}}$
THD	Total Harmonic Distortion $A_v = 20dB$ $V_o = 2V_{pp}$ $R_L = 2k\Omega$ $f = 1kHz$		0.03		%
$\pm V_{opp}$	Output Voltage Swing $R_L = 2k\Omega$ $V_{CC} = \pm 15V$ $V_{CC} = \pm 4V$	± 13	± 3		V
V_{opp}	Large Signal Voltage Swing $R_L = 10k\Omega$ $f = 10kHz$		28		V_{pp}
SR	Slew Rate Unity Gain, $R_L = 2k\Omega$	0.8	1.5		V/ μs
CMR	Common Mode Rejection Ratio $V_{ic} = \pm 10V$	90			dB
SVR	Supply Voltage Rejection Ratio	90			dB
V_{o1}/V_{o2}	Channel Separation, $f = 1kHz$		120		dB

TS512, A

MACROMODEL

** Standard Linear Ics Macromodels, 1993.

** CONNECTIONS :

- * 1 INVERTING INPUT
- * 2 NON-INVERTING INPUT
- * 3 OUTPUT
- * 4 POSITIVE POWER SUPPLY
- * 5 NEGATIVE POWER SUPPLY

.SUBCKT TS512 1 3 2 4 5 (analog)

.MODEL MDTH D IS=1E-8 KF=6.565195E-17
CJO=10F

* INPUT STAGE

CIP 2 5 1.000000E-12
CIN 1 5 1.000000E-12
EIP 10 5 2 5 1
EIN 16 5 1 5 1
RIP 10 11 2.600000E+01
RIN 15 16 2.600000E+01
RIS 11 15 1.061852E+02
DIP 11 12 MDTH 400E-12
DIN 15 14 MDTH 400E-12
VOFP 12 13 DC 0
VOFN 13 14 DC 0
IPOL 13 5 1.000000E-05
CPS 11 15 12.47E-10
DINN 17 13 MDTH 400E-12
VIN 17 5 1.500000E+00
DINR 15 18 MDTH 400E-12
VIP 4 18 1.500000E+00
FCP 4 5 VOFP 3.400000E+01
FCN 5 4 VOFN 3.400000E+01

FIBP 2 5 VOFN 1.000000E-02
FIBN 5 1 VOFP 1.000000E-02
* AMPLIFYING STAGE
FIP 5 19 VOFP 9.000000E+02
FIN 5 19 VOFN 9.000000E+02
RG1 19 5 1.727221E+06
RG2 19 4 1.727221E+06
CC 19 5 6.000000E-09
DOPM 19 22 MDTH 400E-12
DONM 21 19 MDTH 400E-12
HOPM 22 28 VOUT 6.521739E+03
VIPM 28 4 1.500000E+02
HONM 21 27 VOUT 6.521739E+03
VINM 5 27 1.500000E+02
GCOMP 5 4 4 5 6.485084E-04
RPM1 5 80 1E+06
RPM2 4 80 1E+06
GAVPH 5 82 19 80 2.59E-03
RAVPHGH 82 4 771
RAVPHGB 82 5 771
RAVPHDH 82 83 1000
RAVPHDB 82 84 1000
CAVPHH 4 83 0.331E-09
CAVPHB 5 84 0.331E-09
EOUT 26 23 82 5 1
VOUT 23 5 0
ROUT 26 3 6.498455E+01
COUT 3 5 1.000000E-12
DOP 19 25 MDTH 400E-12
VOP 4 25 1.742230E+00
DON 24 19 MDTH 400E-12
VON 24 5 1.742230E+00
.ENDS

ELECTRICAL CHARACTERISTICS

V_{cc} = ±15V, T_{amb} = 25°C (unless otherwise specified)

Symbol	Conditions	Value	Unit
V _{io}		0	mV
A _{vd}	R _L = 2kΩ	100	V/mV
I _{cc}	No load, per operator	350	μA
V _{icm}		-13.5 to 13.5	V
V _{OH}	R _L = 2kΩ	+13	V
V _{OL}	R _L = 2kΩ	-13	V
I _{sink}	V _o = 0V	23	mA
I _{source}	V _o = 0V	23	mA
GBP	R _L = 2kΩ, C _L = 100pF	3	MHz
SR	R _L = 2kΩ	1.4	V/μs
∅m	R _L = 2kΩ, C _L = 100pF	55	Degrees

TS512, A

PACKAGE MECHANICAL DATA

8 PINS - PLASTIC DIP

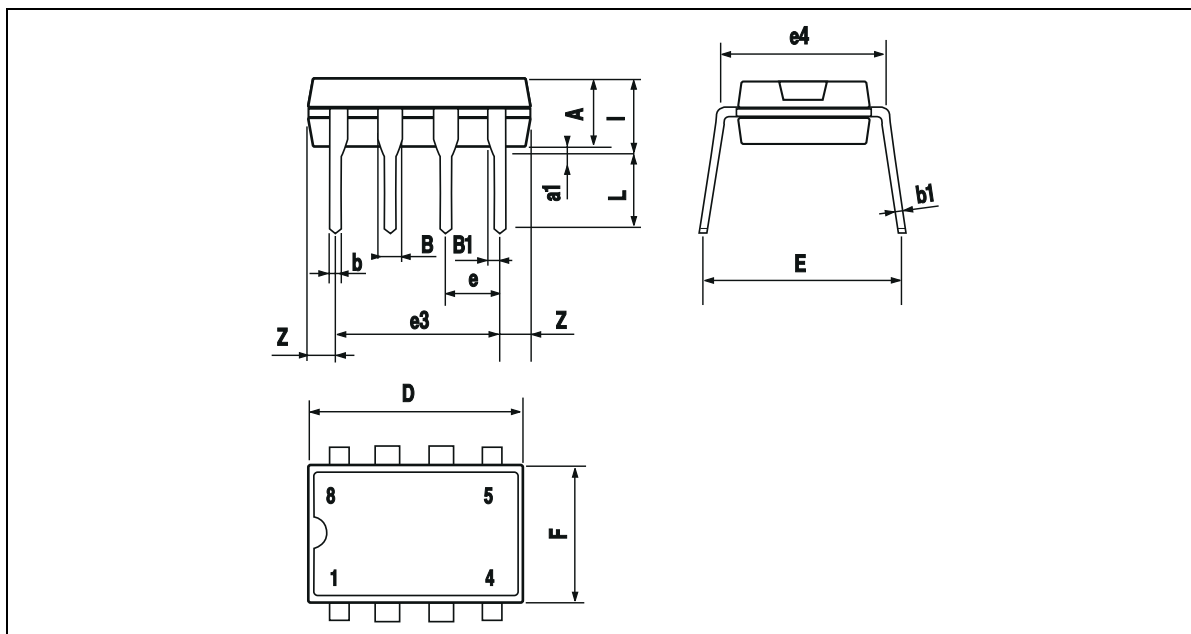

Dim.	Millimeters			Inches		
	Min.	Typ.	Max.	Min.	Typ.	Max.
A		3.32			0.131	
a1	0.51			0.020		
B	1.15		1.65	0.045		0.065
b	0.356		0.55	0.014		0.022
b1	0.204		0.304	0.008		0.012
D			10.92			0.430
E	7.95		9.75	0.313		0.384
e		2.54			0.100	
e3		7.62			0.300	
e4		7.62			0.300	
F			6.6			0.260
i			5.08			0.200
L	3.18		3.81	0.125		0.150
Z			1.52			0.060

TS512, A

PACKAGE MECHANICAL DATA

8 PINS - PLASTIC MICROPACKAGE (SO)

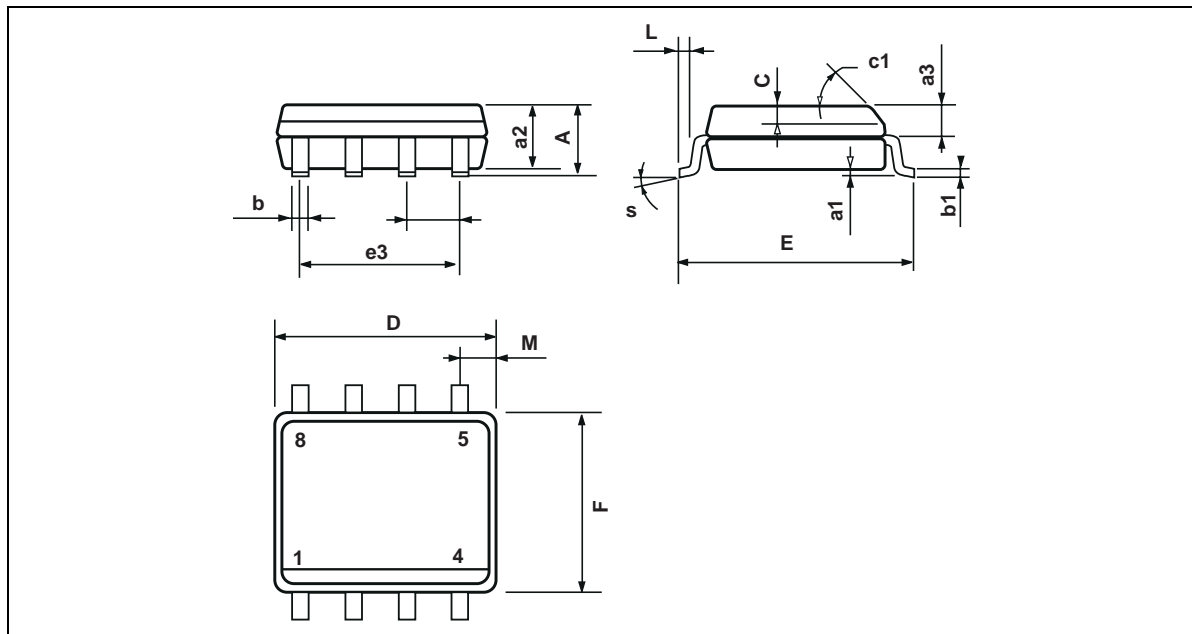

Dim.	Millimeters			Inches		
	Min.	Typ.	Max.	Min.	Typ.	Max.
A			1.75			0.069
a1	0.1		0.25	0.004		0.010
a2			1.65			0.065
a3	0.65		0.85	0.026		0.033
b	0.35		0.48	0.014		0.019
b1	0.19		0.25	0.007		0.010
C	0.25		0.5	0.010		0.020
c1	45° (typ.)					
D	4.8		5.0	0.189		0.197
E	5.8		6.2	0.228		0.244
e		1.27			0.050	
e3		3.81			0.150	
F	3.8		4.0	0.150		0.157
L	0.4		1.27	0.016		0.050
M			0.6			0.024
S	8° (max.)					

Information furnished is believed to be accurate and reliable. However, STMicroelectronics assumes no responsibility for the consequences of use of such information nor for any infringement of patents or other rights of third parties which may result from its use. No license is granted by implication or otherwise under any patent or patent rights of STMicroelectronics. Specifications mentioned in this publication are subject to change without notice. This publication supersedes and replaces all information previously supplied. STMicroelectronics products are not authorized for use as critical components in life support devices or systems without express written approval of STMicroelectronics.

© The ST logo is a registered trademark of STMicroelectronics

© 2001 STMicroelectronics - Printed in Italy - All Rights Reserved
 STMicroelectronics GROUP OF COMPANIES

Australia - Brazil - Canada - China - Finland - France - Germany - Hong Kong - India - Israel - Italy - Japan - Malaysia
 Malta - Morocco - Singapore - Spain - Sweden - Switzerland - United Kingdom - United States

© <http://www.st.com>