

Excellent Integrated System Limited

Stocking Distributor

Click to view price, real time Inventory, Delivery & Lifecycle Information:

[STMicroelectronics](#)

[TSM104WAID](#)

For any questions, you can email us directly:

sales@integrated-circuit.com



TSM104W/A

QUAD OPERATIONAL AMPLIFIER AND PROGRAMMABLE VOLTAGE REFERENCE

OPERATIONAL AMPLIFIERS

- LOW SUPPLY CURRENT : 375 μ A/op. (@ $V_{CC} = 5V$)
- LOW INPUT BIAS CURRENT : 20nA
- MEDIUM SPEED : 0.9MHz
- LOW INPUT OFFSET VOLTAGE : 0.5mV typ for TSM104WA
- WIDE POWER SUPPLY RANGE : $\pm 1.5V$ to $\pm 15V$
- 2kV ESD PROTECTION

VOLTAGE REFERENCE

- ADJUSTABLE OUTPUT VOLTAGE : V_{ref} to 36V
- 0.4% AND 1% VOLTAGE PRECISION
- SINK CURRENT CAPABILITY : 1 to 100mA
- TYPICAL OUTPUT IMPEDANCE : 0.2 Ω

DESCRIPTION

The TSM104W is a monolithic IC that includes four op-amps and an adjustable shunt voltage reference. This device is offering space and cost saving in many applications like power supply management or data acquisition systems.

PIN CONNECTIONS (top view)

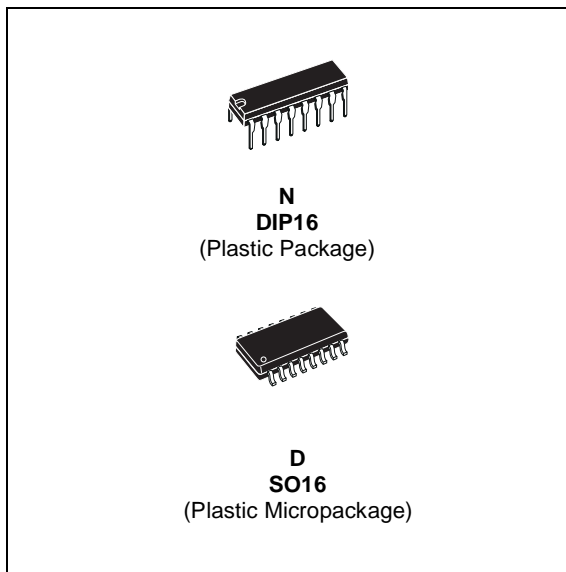
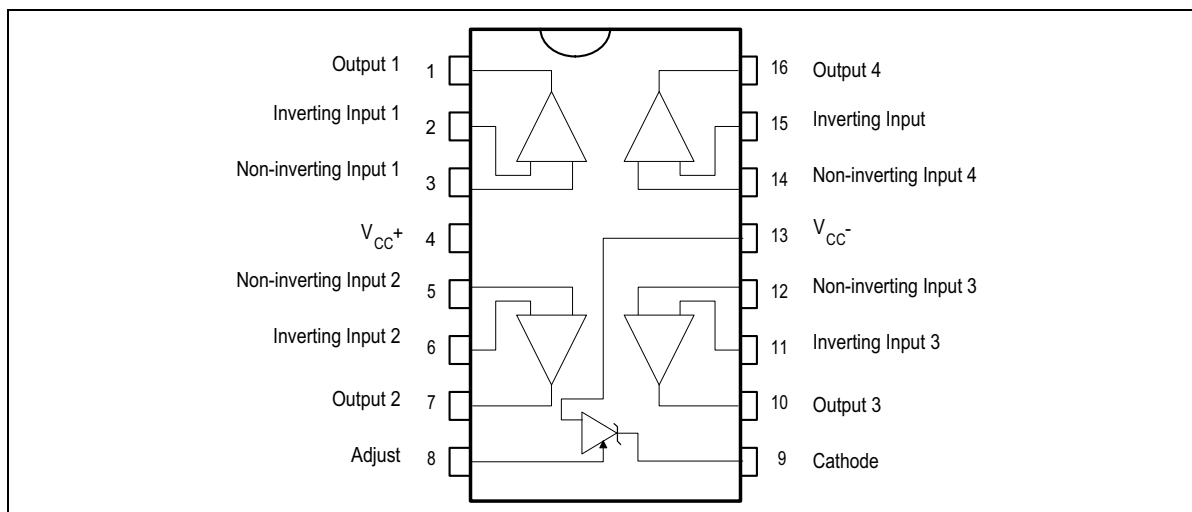

ORDER CODE

Part Number	Temperature Range	Package	
		N	D
TSM104WI/AI	-40°C, +105°C	•	•

N = Dual in Line Package (DIP)
 D = Small Outline Package (SO) - also available in Tape & Reel (DT)

TSM104W/A
ABSOLUTE MAXIMUM RATINGS

Symbol	Parameter	Value	Unit
V_{CC}	Supply Voltage	36	V
V_{id}	Differential Input Voltage	36	V
V_i	Input Voltage	-0.3 to $V_{CC} + 0.3$	V
	Output Short-circuit Duration	Infinite	
T_{oper}	Operating Free-Air Temperature Range	-55 to +125	°C
T_j	Maximum Junction Temperature	150	°C
R_{thja}	Thermal Resistance Junction to Ambient (SO package)	150	°C/W
ESD	Electrostatic Discharge Protection	2	kV

ELECTRICAL CHARACTERISTICS
 $V_{CC}^+ = 5V, V_{CC}^- = 0V, T_{amb} = 25^\circ C$ (unless otherwise specified)

Symbol	Parameter	Min	Typ	Max	Unit
I_{CC}	Total Supply Current, excluding current in the Voltage Reference $V_{CC}^+ = 5V$, no load $T_{min.} < T_{amb} < T_{max.}$ $V_{CC}^+ = 30V$, no load $T_{min.} < T_{amb} < T_{max.}$		1.4	2.4 4	mA

TSM104W/A
ELECTRICAL CHARACTERISTICS
 $V_{CC}^+ = 5V$, $V_{CC}^- = \text{Ground}$, $V_O = 1.4V$, $T_{amb} = 25^\circ\text{C}$ (unless otherwise specified)

Symbol	Parameter	Min.	Typ.	Max.	Unit
V_{io}	Input Offset Voltage TSM104W, $T_{amb} = 25^\circ\text{C}$ $T_{min} \leq T_{amb} \leq T_{max}$ TSM104WA, $T_{amb} = 25^\circ\text{C}$ $T_{min} \leq T_{amb} \leq T_{max}$		1 0.5	5 6 3 4	mV
ΔV_{io}	Input Offset Voltage Drift		7		$\mu\text{V}/^\circ\text{C}$
I_{io}	Input Offset Current $T_{min} \leq T_{amb} \leq T_{max}$		2	30 50	nA
I_{ib}	Input Bias Current $T_{min} \leq T_{amb} \leq T_{max}$		20	150 200	nA
A_{vd}	Large Signal Voltage Gain $V_{CC} = 15V$, $R_L = 2k$ $V_O = 1.4V$ to $11.4V$ $T_{min} \leq T_{amb} \leq T_{max}$	50 25	100		V/mV
SVR	Supply Voltage Rejection Ratio $V_{CC} = 5V$ to $30V$	65	100		dB
V_{icm}	Input Voltage Mode Voltage Range $V_{CC} = +30V$ see note ¹⁾ $T_{min} \leq T_{amb} \leq T_{max}$	0 0		$V_{CC}^+ - 1.5$ $V_{CC}^+ - 2$	V
CMR	Common Mode Rejection Ratio $T_{min} \leq T_{amb} \leq T_{max}$	70 60	85		dB
I_{source}	Output Current Source $V_O = 2V$, $V_{CC} = +15V$, $V_{id} = +1V$	20	40		mA
I_o	Output Short Circuit to Ground $V_{CC} = +15V$		40	60	mA
I_{sink}	Output Current Sink $V_{id} = -1V$ $V_{CC} = +15V$, $V_O = +2V$	10	20		mA
V_{OH}	High Level Output Voltage $R_L = 10k$, $V_{CC}^+ = 30V$ $T_{amb} = 25^\circ\text{C}$ $T_{min} \leq T_{amb} \leq T_{max}$	27 27	28		V
V_{OL}	Low Level Output Voltage $R_L = 10k$ $T_{min} \leq T_{amb} \leq T_{max}$		5	20 20	mV
SR	Slew Rate at Unity Gain $V_i = 0.5$ to $3V$, $V_{CC} = 15V$ $R_L = 2k\Omega$, $C_L = 100pF$, unity gain	0.1	0.3		V/ μs
GBP	Gain Bandwidth Product $V_{CC} = 30V$, $R_L = 2k$, $C_L = 100pF$ $f = 100kHz$, $V_{in} = 10mV$	0.5	0.9		MHz
THD	Total Harmonic Distortion $f = 1kHz$ $A_V = 20dB$, $R_L = 2$, $V_{CC} = 30V$ $C_L = 100pF$, $V_O = 2V_{pp}$		0.02		%
e_n	Equivalent Input Noise Voltage $f = 1kHz$, $V_{CC} = 30V$, $R_s = 100\Omega$		50		$\frac{nV}{\sqrt{Hz}}$
C_s	Channel Separation $1kHz < f < 20kHz$		120		dB

1. The input common-mode voltage of either input signal voltage should not be allowed to go negative by more than 0.3V. The upper end of the common-mode voltage range is $V_{CC}^+ - 1.5V$, but either of both inputs can go to $V_{CC}^+ + 0.3V$ without damage.

TSM104W/A
VOLTAGE REFERENCE

Symbol	Conditions	Value	Unit
I_k	Cathode Current	1 to 100	mA

Symbol	Parameter	Min	Typ	Max	Unit
V_{ref}	Reference Input Voltage TSM104W, $T_{amb} = 25^{\circ}\text{C}$ $T_{min} \leq T_{amb} \leq T_{max}$ TSM104WA, $T_{amb} = 25^{\circ}\text{C}$ $T_{min} \leq T_{amb} \leq T_{max}$	2.475 2.45 2.49 2.48	2.5 2.5	2.525 2.55 2.51 2.52	V
ΔV_{ref}	Reference Input Voltage Deviation Over Temperature Range $V_{KA} = V_{ref}$, $I_K = 10\text{mA}$ $T_{min} \leq T_{amb} \leq T_{max}$		7	30	mV
$\frac{\Delta V_{ref}}{\Delta V_{KA}}$	Ratio of Change in Reference Input Voltage to Change in Cathode to Anode Voltage $I_K = 10\text{mA}$, $\Delta V_{KA} = 36\text{V to } 3\text{V}$	-2	-1.1		mV/V
I_{ref}	Reference Input Current $I_K = 10\text{mA}$ $T_{min} \leq T_{amb} \leq T_{max}$		1.5	2.5 3	μA
ΔI_{ref}	Reference Input Current Deviation over T° Range		0.8	1.2	μA
I_{min}	Minimum Cathode Current for Regulation $V_{KA} = V_{ref}$		0.5	1	mA
I_{off}	Off-State Cathode Current		180	500	nA
$ Z_{KA} $	Dynamic Impedance - note 1 $V_{KA} = V_{ref}$, $\Delta I_K = 1$ to 100mA , $f < 1\text{kHz}$		0.2	0.5	Ω

1) The dynamic impedance is defined as $|Z_{KA}| = \frac{\Delta V_{KA}}{\Delta I_K}$

OPERATIONAL AMPLIFIERS

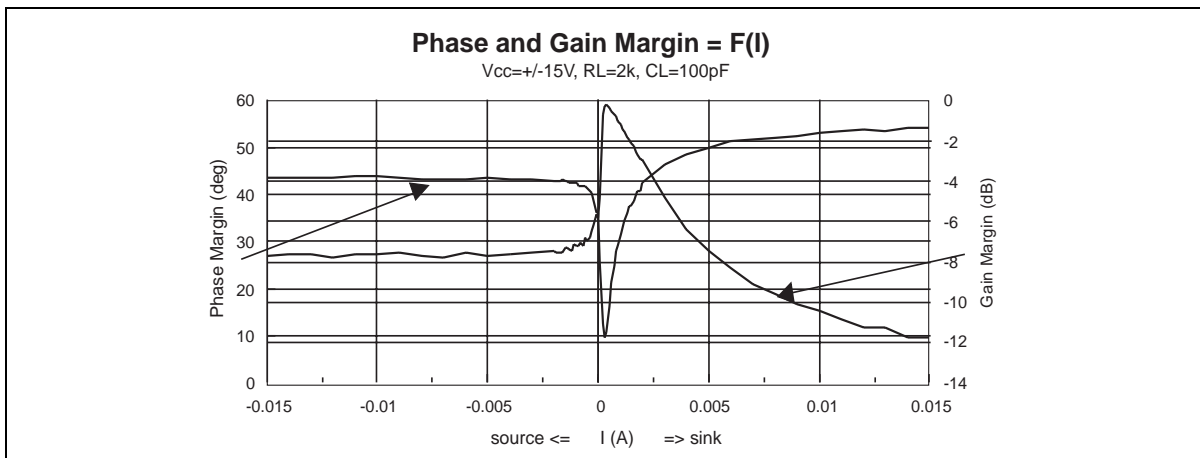
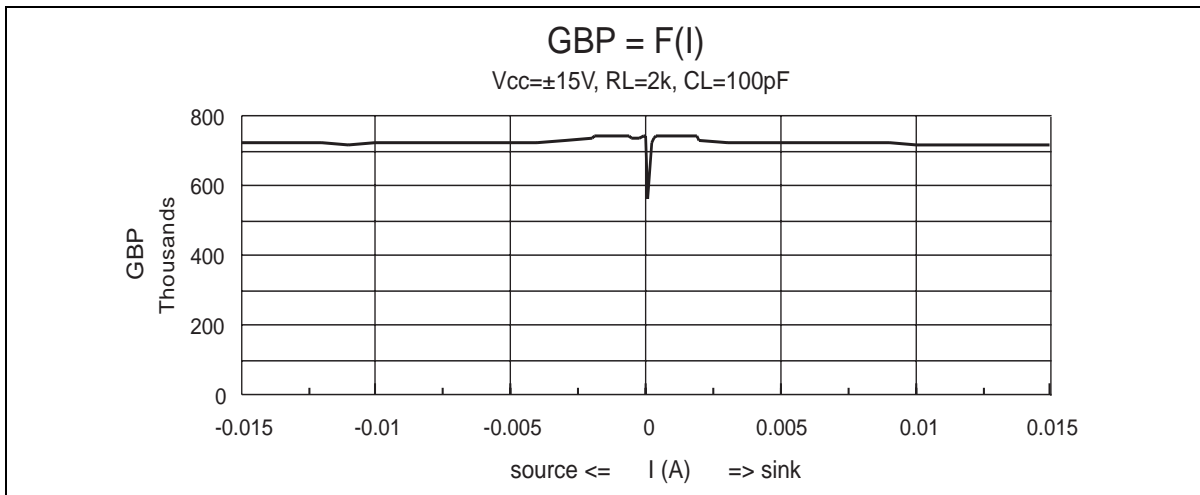
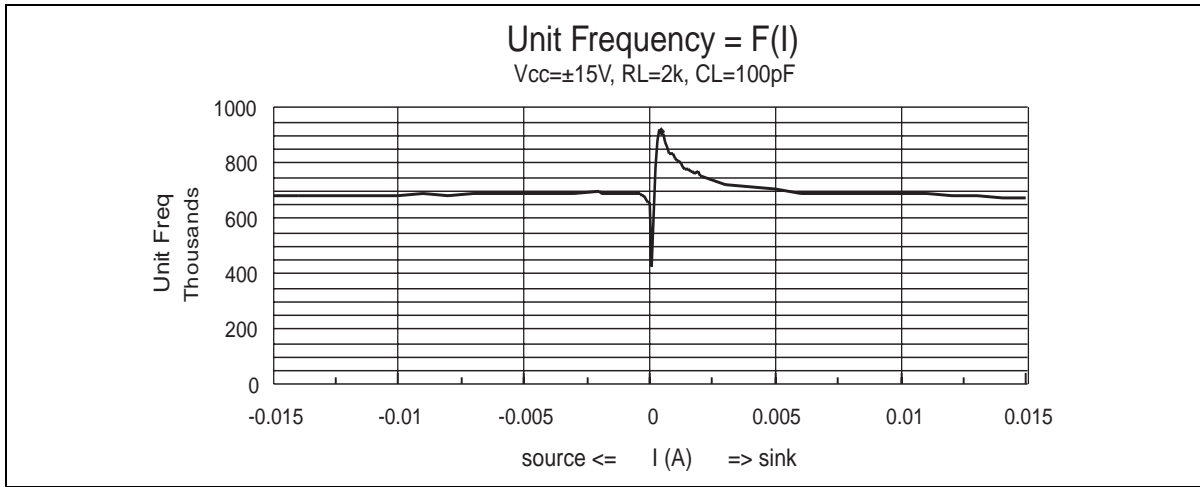

TSM104W/A

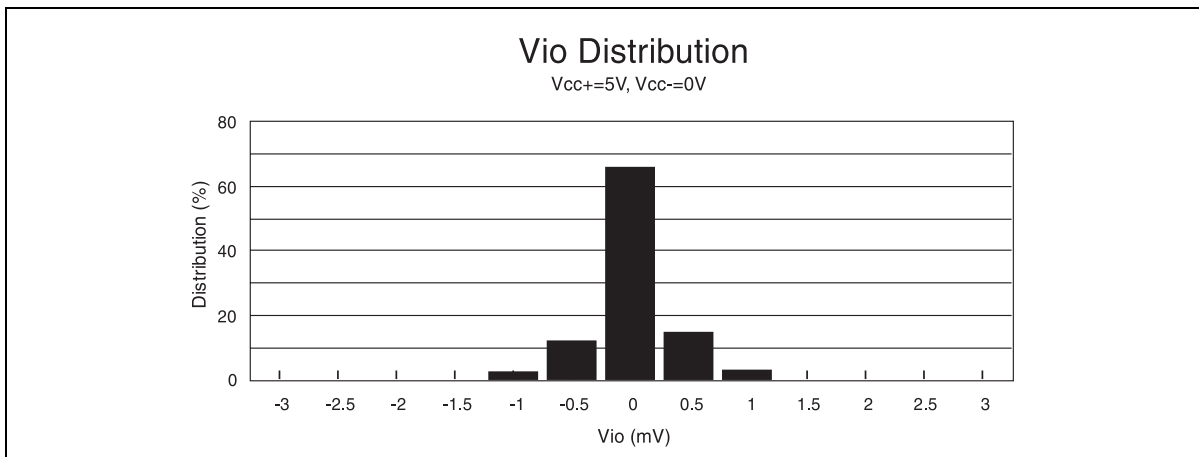
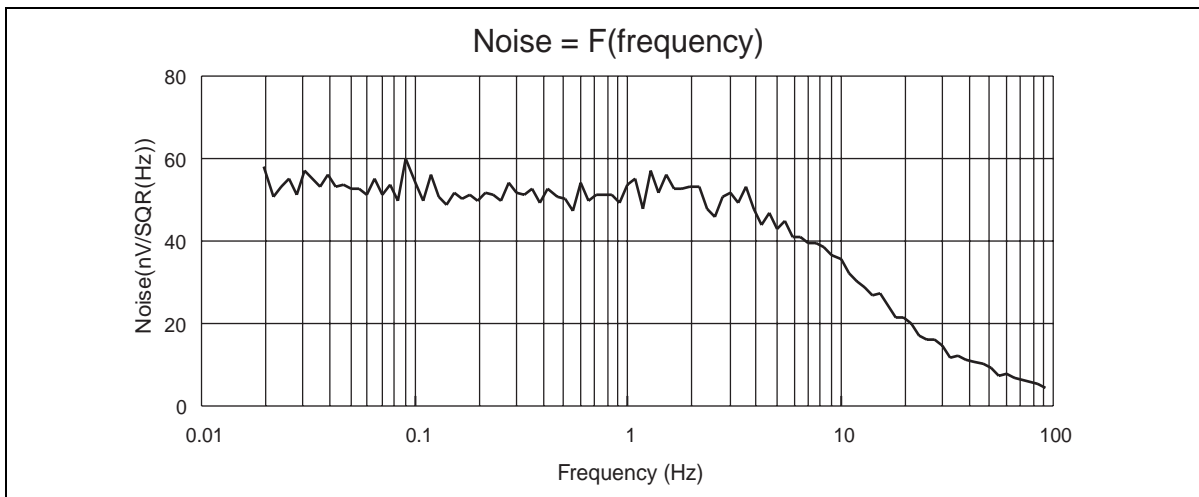
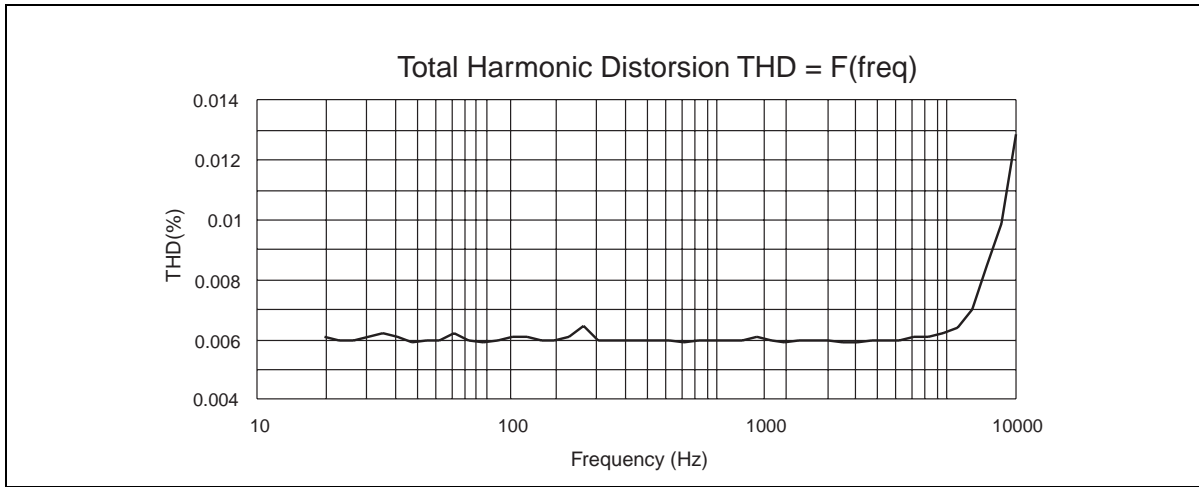

VOLTAGE REFERENCE

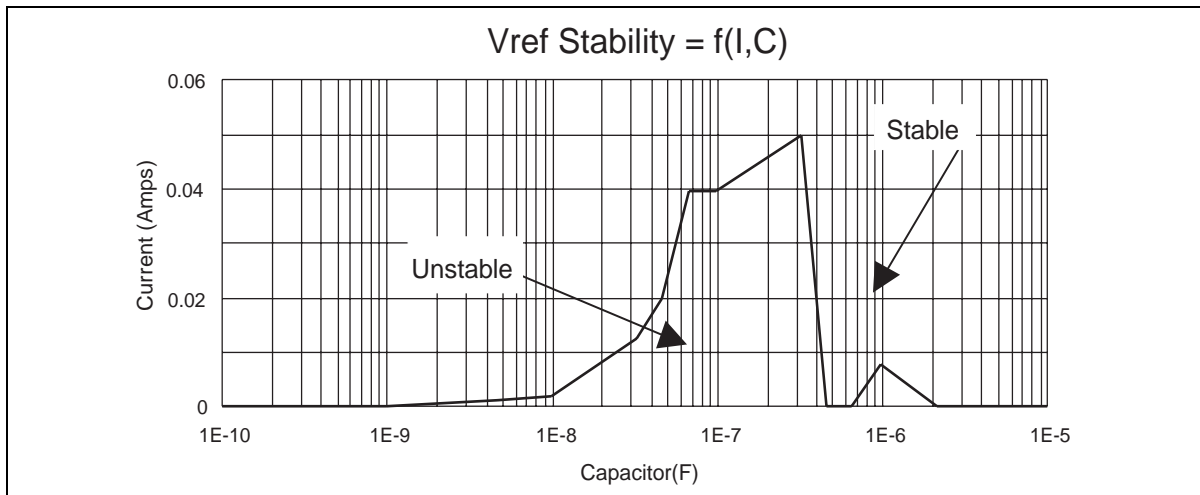
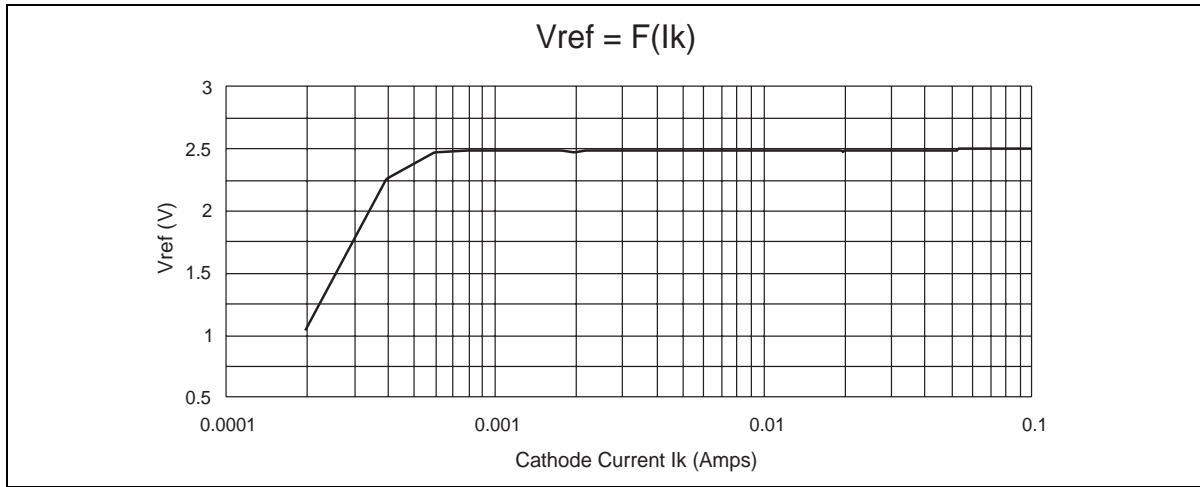

TSM104W/A

PACKAGE MECHANICAL DATA

16 PINS - PLASTIC PACKAGE

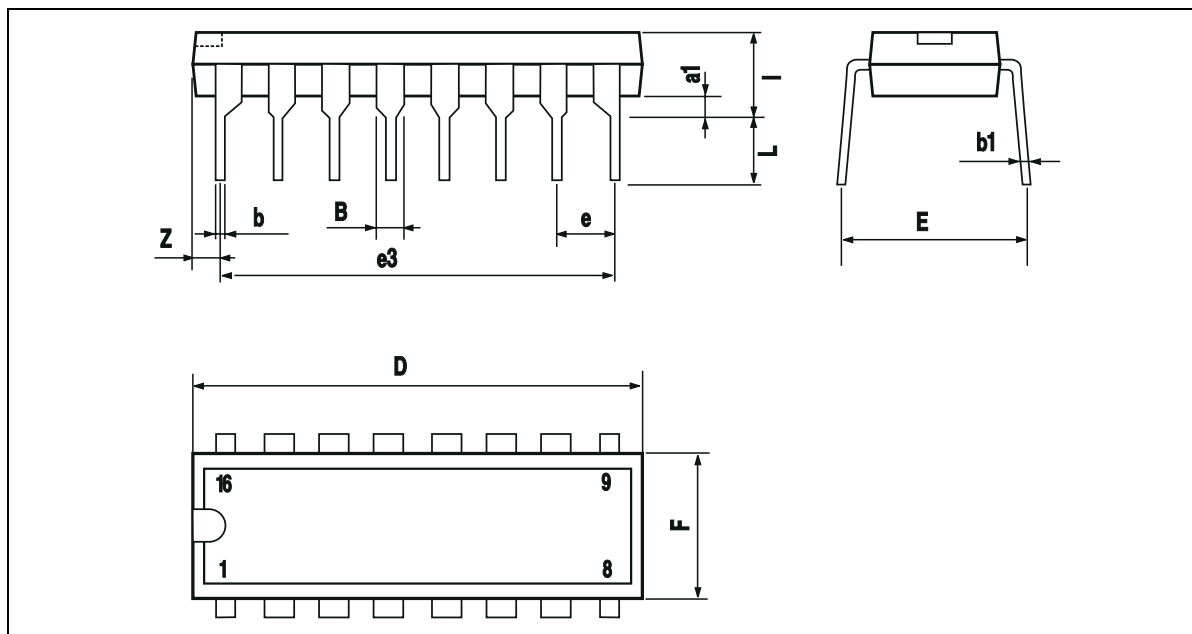

Dim.	Millimeters			Inches		
	Min.	Typ.	Max.	Min.	Typ.	Max.
a1	0.51			0.020		
B	0.77		1.65	0.030		0.065
b		0.5			0.020	
b1		0.25			0.010	
D			20			0.787
E		8.5			0.335	
e		2.54			0.100	
e3		17.78			0.700	
F			7.1			0.280
i			5.1			0.201
L		3.3			0.130	
Z			1.27			0.050

TSM104W/A

PACKAGE MECHANICAL DATA
 16 PINS - PLASTIC MICROPACKAGE (SO)

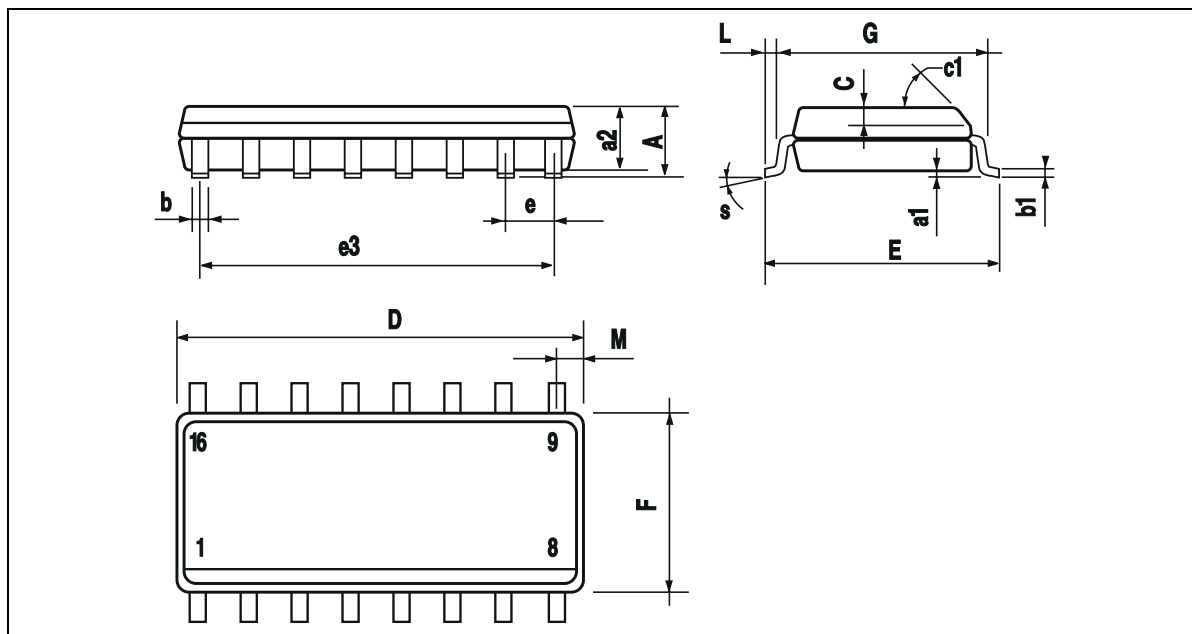

Dim.	Millimeters			Inches		
	Min.	Typ.	Max.	Min.	Typ.	Max.
A			1.75			0.069
a1	0.1		0.2	0.004		0.008
a2			1.6			0.063
b	0.35		0.46	0.014		0.018
b1	0.19		0.25	0.007		0.010
C		0.5			0.020	
c1	45° (typ.)					
D	9.8		10	0.386		0.394
E	5.8		6.2	0.228		0.244
e		1.27			0.050	
e3		8.89			0.350	
F	3.8		4.0	0.150		0.157
G	4.6		5.3	0.181		0.209
L	0.5		1.27	0.020		0.050
M			0.62			0.024
S	8° (max.)					

Information furnished is believed to be accurate and reliable. However, STMicroelectronics assumes no responsibility for the consequences of use of such information nor for any infringement of patents or other rights of third parties which may result from its use. No license is granted by implication or otherwise under any patent or patent rights of STMicroelectronics. Specifications mentioned in this publication are subject to change without notice. This publication supersedes and replaces all information previously supplied. STMicroelectronics products are not authorized for use as critical components in life support devices or systems without express written approval of STMicroelectronics.

The ST logo is a registered trademark of STMicroelectronics

© 2003 STMicroelectronics - All Rights Reserved
 STMicroelectronics GROUP OF COMPANIES

Australia - Brazil - China - Finland - France - Germany - Hong Kong - India - Italy - Japan - Malaysia - Malta - Morocco
 Singapore - Spain - Sweden - Switzerland - United Kingdom
<http://www.st.com>