

Excellent Integrated System Limited

Stocking Distributor

Click to view price, real time Inventory, Delivery & Lifecycle Information:

[Panasonic Electronic Components](#)
[LN48YCP](#)

For any questions, you can email us directly:

sales@integrated-circuit.com

丸形 Round Type

φ 3.0mm Series

Type No. Lighting Color
 LN48YPP Amber
 LN48YCPP Amber
 LN48CPP Amber

絶対最大定格 Absolute Maximum Ratings (Ta=25 °C)

Lighting Color	P _D (mW)	I _F (mA)	I _{FP} (mA)*	V _R (V)	Topr (°C)	Tstg (°C)
Amber	90	30	150	4	-25~+85	-30~+100

* I_{FP}の条件は、 duty 10%. Pulse width 1 msec. The condition of I_{FP} is duty 10%, Pulse width 1 msec

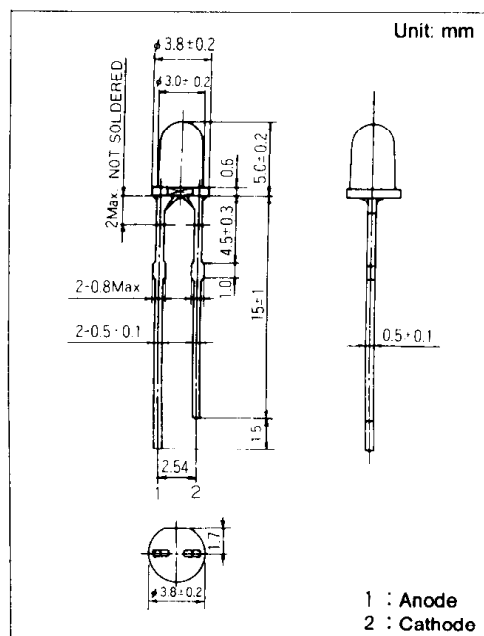

電気的光学的特性 Electro-Optical Characteristics (Ta=25 °C)

Type No.	Lighting Color	Lens Color	I ₀			V _F		λ _P	Δλ	I _F	I _R	
			Typ.	Min.	I _F	Typ.	Max.				Max.	V _R
LN48YPP	Amber	Amber Diffused	5.0	1.7	20	2.2	2.8	590	30	20	10	4
LN48YCPP	Amber	Amber Clear	6.0	3.0	20	2.2	2.8	590	30	20	10	4
LN48CPP	Amber	Clear	10.0	4.0	20	2.2	2.8	590	30	20	10	4
Unit	—	—	mcd	mcd	mA	V	V	nm	nm	mA	μA	V

