

Excellent Integrated System Limited

Stocking Distributor

Click to view price, real time Inventory, Delivery & Lifecycle Information:

[Fairchild Semiconductor](#)
[MM74HC594MX](#)

For any questions, you can email us directly:

sales@integrated-circuit.com



January 1992
Revised May 1999

MM74HC594 8-Bit Shift Register with Output Registers

General Description

This high speed shift register utilizes advanced silicon-gate CMOS technology. This device possesses the high noise immunity and low power consumption of standard CMOS integrated circuits, as well as the ability to drive 15 LS-TTL loads.

This device contains an 8-bit serial-in, parallel-out shift register that feeds an 8-bit D-type storage register. Separate clocks and direct overriding clears are provided for both the shift register and the storage register. The shift register has a direct-overriding clear, serial input, and serial output (standard) pins for cascading. Both the shift register and storage register use positive-edge triggered clocks. If both clocks are connected together, the shift register state will always be one clock pulse ahead of the storage register.

The 74HC logic family is speed, function, and pin-out compatible with the standard 74LS logic family. All inputs are protected from damage due to static discharge by internal diode clamps to V_{CC} and ground.

Features

- Low quiescent current: 80 μ A maximum
- Low input current: 1 μ A maximum
- 8-bit serial-in, parallel-out shift register with storage
- Wide operating voltage range: 2V to 6V
- Cascadable
- Shift register has direct clear
- Guaranteed shift frequency: DC to 30 MHz

Ordering Code:

Order Number	Package Number	Package Description
MM74HC594M	M16A	16-Lead Small Outline Integrated Circuit (SOIC), JEDEC MS-012, 0.150 Narrow
MM74HC594N	N16E	16-Lead Plastic Dual-In-Line Package (PDIP), JEDEC MS-001, 0.300 Wide

Devices also available in Tape and Reel. Specify by appending the suffix letter "X" to the ordering code.

Connection Diagram

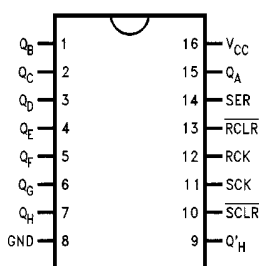

Truth Table

RCK	SCK	SCLR	RCLR	Function
X	X	X	L	Storage Register cleared
X	X	L	X	Shift Register cleared $Q'_H = 0$
X	\uparrow	H	H	Shift Register clocked $Q_N = Q_{N-1}, Q_0 = SER$
\uparrow	X	H	H	Contents of Shift Register transferred to output latches

MM74HC594

Logic Diagram

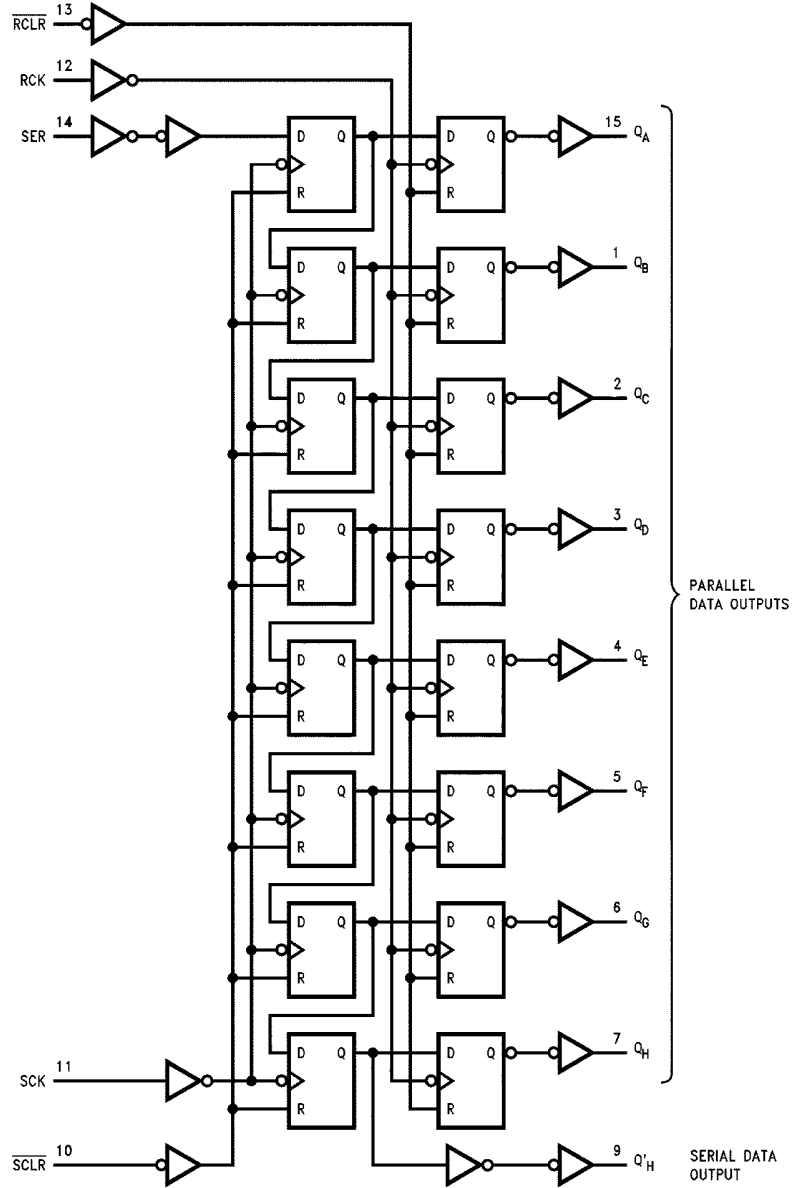

Absolute Maximum Ratings (Note 1)		Recommended Operation Conditions						
(Note 2)								
Supply Voltage (V_{CC})	-0.5 to +7.0V							
DC Input Voltage (V_{IN})	-1.5 to $V_{CC} + 1.5V$	Min	Max Units					
DC Output Voltage (V_{OUT})	-0.5 to $V_{CC} + 0.5V$	2	6 V					
Clamp Diode Current (I_{IK}, I_{OK})	± 20 mA	0	V_{CC} V					
DC Output Current, per pin (I_{OUT})	± 35 mA	(V_{IN}, V_{OUT})						
DC V_{CC} or GND Current, per pin (I_{CC})	± 70 mA	Operating Temperature Range (T_A)	-40 +85 °C					
Storage Temperature Range (T_{STG})	-65°C to +150°C	Input Rise or Fall Times						
Power Dissipation (P_D)		(t_r, t_f) $V_{CC} = 2.0V$	1000 ns					
(Note 3)	600 mW	$V_{CC} = 4.5V$	500 ns					
S.O. Package only	500 mW	$V_{CC} = 6.0V$	400 ns					
Lead Temperature (T_L)		Note 1: Absolute Maximum Ratings are those values beyond which damage to the device may occur.						
(Soldering 10 seconds)	260°C	Note 2: Unless otherwise specified all voltages are referenced to ground.						
		Note 3: Power Dissipation temperature derating—plastic "N" package: -12 mW/°C from 65°C to 85°C.						
DC Electrical Characteristics (Note 4)								
Symbol	Parameter	Conditions	V_{CC}	$T_A = 25^\circ C$		$T_A = -40 \text{ to } 85^\circ C$		Units
				Typ	Guaranteed Limits			
V_{IH}	Minimum HIGH Level Input Voltage		2.0V		1.5	1.5	V	
			4.5V		3.15	3.15		
			6.0V		4.2	4.2		
V_{IL}	Maximum LOW Level Input Voltage		2.0V		0.5	0.5	V	
			4.5V		1.35	1.35		
			6.0V		1.8	1.8		
V_{OH}	Minimum HIGH Level Output Voltage	$V_{IN} = V_{IH} \text{ or } V_{IL}$ $ I_{OUT} \leq 20 \mu A$	2.0V	2.0	1.9	1.9	V	
			4.5V	4.5	4.4	4.4		
			6.0V	6.0	5.9	5.9		
Q_H		$V_{IN} = V_{IH} \text{ or } V_{IL}$ $ I_{OUT} \leq 4.0 \text{ mA}$ $ I_{OUT} \leq 5.2 \text{ mA}$	4.5V	4.7	3.98	3.84	V	
			6.0V	5.2	5.48	5.34		
			$Q_A \text{ thru } Q_H$	$V_{IN} = V_{IH} \text{ or } V_{IL}$ $ I_{OUT} \leq 6.0 \text{ mA}$ $ I_{OUT} \leq 7.8 \text{ mA}$	4.5V	4.2		3.98
6.0V	5.7	5.48			5.34			
V_{OL}	Maximum LOW Level Output Voltage	$V_{IN} = V_{IH} \text{ or } V_{IL}$ $ I_{OUT} \leq 20 \mu A$			2.0V	0	0.1	0.1
			4.5V	0	0.1	0.1		
			6.0V	0	0.1	0.1		
Q_H		$V_{IN} = V_{IH} \text{ or } V_{IL}$ $ I_{OUT} \leq 4.0 \text{ mA}$ $ I_{OUT} \leq 5.2 \text{ mA}$	4.5V	0.2	0.26	0.33	V	
			6.0V	0.2	0.26	0.33		
			$Q_A \text{ thru } Q_H$	$V_{IN} = V_{IH} \text{ or } V_{IL}$ $ I_{OUT} \leq 6.0 \text{ mA}$ $ I_{OUT} \leq 7.8 \text{ mA}$	4.5V	0.2		0.26
6.0V	0.2	0.26			0.33			
I_{IN}	Maximum Input Current	$V_{IN} = V_{CC} \text{ or } GND$			6.0V		± 0.1	± 1.0
I_{CC}	Maximum Quiescent Supply Current	$V_{IN} = V_{CC} \text{ or } GND$ $I_{OUT} = 0 \mu A$	6.0V		8.0	80	μA	
Note 4: For a power supply of 5V $\pm 10\%$ the worst case output voltages (V_{OH} , and V_{OL}) occur for HC at 4.5V. Thus the 4.5V values should be used when designing with this supply. Worst case V_{IH} and V_{IL} occur at $V_{CC} = 5.5V$ and 4.5V respectively. (The V_{IH} value at 5.5V is 3.85V.) The worst case leakage current (I_{IN} , I_{CC} , and I_{OZ}) occur for CMOS at the higher voltage and so the 6.0V values should be used.								

MM74HC594

AC Electrical Characteristics								
<small>V_{CC} = 2.0V to 6.0V, C_L = 50 pF, t_r = t_f = 6 ns (unless otherwise specified)</small>								
Symbol	Parameter	Conditions	V _{CC}	T _A = 25°C		-40°C to +85°C		Units
				Typ	Guaranteed Limits			
f _{MAX}	Maximum Operating Frequency	C _L = 50 pF	2.0V 4.5V 6.0V		6 30 35	4.8 24 28		MHz
t _{PHL} , t _{PLH}	Maximum Propagation Delay from SCK to Q' _H	C _L = 50 pF	2.0V 4.5V 6.0V		150 30 25	185 37 31		ns
t _{PHL} , t _{PLH}	Maximum Propagation Delay from RCK to Q _A thru Q _H	C _L = 50 pF	2.0V		150	185		ns
		C _L = 150 pF	2.0V		200	250		ns
		C _L = 50 pF	4.5V		30	37		ns
		C _L = 150 pF	4.5V		40	50		ns
		C _L = 50 pF C _L = 150 pF	6.0V 6.0V		25 34	31 43		ns
t _{PHL} , t _{PLH}	Maximum Propagation Delay from SCLR to Q' _H		2.0V 4.5V 6.0V		150 30 25	185 37 31		ns
t _{PHL}	Maximum Propagation Delay from RCLR to Q _A thru Q _H	C _L = 50 pF	2.0V 4.5V 6.0V		125 25 21	155 31 26		ns
		C _L = 150 pF	2.0V 4.5V 6.0V		200 40 34	250 50 43		ns
t _S	SCLR LOW to RCK		2.0V 4.5V 6.0V		50 10 9	63 13 11		ns
t _S	RCLR HIGH to SCK		2.0V 4.5V 6.0V		5 5 5	5 5 5		ns
t _S	Minimum Setup Time from SER to SCK		2.0V 4.5V 6.0V		90 18 15	110 22 19		ns
t _R	Minimum Removal Time from SCLR to SCK		2.0V 4.5V 6.0V		20 10 10	20 10 10		ns
t _S	Minimum Setup Time from SCK to RCK		2.0V 4.5V 6.0V		90 18 15	110 22 19		ns
t _H	Minimum Hold Time SER to SCK		2.0V 4.5V 6.0V		5 5 5	5 5 5		ns
t _W	Minimum Pulse Width of SCK or SCLR or RCK or RCLR		2.0V 4.5V 6.0V		100 20 17	125 25 21		ns
t _r , t _f	Maximum Input Rise and Fall Time, Clock		2.0V 4.5V 6.0V		1000 500 400	1000 500 400		ns
t _{RHL} , t _{TLH}	Maximum Output Rise and Fall Time Q _A - Q _H		2.0V		60	75		ns
			4.5V		12	15		ns
			6.0V		10	13		ns
t _{RHL} , t _{TLH}	Maximum Output Rise and Fall Time Q' _H		2.0V		75	95		ns
			4.5V		15	19		ns
			6.0V		13	16		ns

AC Electrical Characteristics (Continued)							
Symbol	Parameter	Conditions	V _{CC}	T _A = 25°C		Units	
				Typ	Guaranteed Limits		
C _{PD}	Power Dissipation Capacitance, Outputs Enabled (Note 5)	$\overline{G} = V_{CC}$ $\overline{G} = GND$		90		pF	
				150			
C _{IN}	Maximum Input Capacitance			5	10	10	pF
C _{OUT}	Maximum Output Capacitance			15	20	20	pF

Note 5: C_{PD} determines the no load dynamic power consumption, and the no load dynamic current consumption.

MM74HC594

Physical Dimensions inches (millimeters) unless otherwise noted

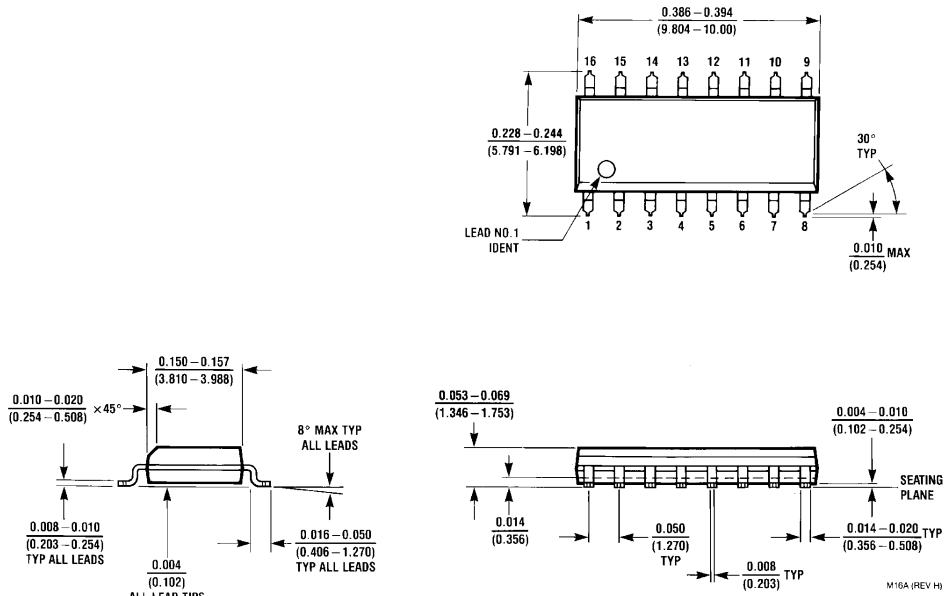

16-Lead Small Outline Integrated Circuit (SOIC), JEDEC MS-012, 0.150 Narrow Package Number M16A

Physical Dimensions inches (millimeters) unless otherwise noted (Continued)

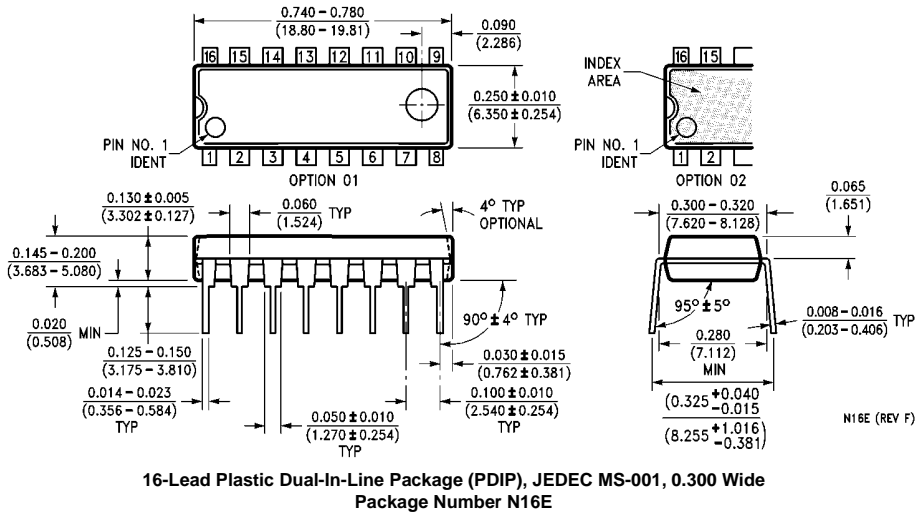

LIFE SUPPORT POLICY

FAIRCHILD'S PRODUCTS ARE NOT AUTHORIZED FOR USE AS CRITICAL COMPONENTS IN LIFE SUPPORT DEVICES OR SYSTEMS WITHOUT THE EXPRESS WRITTEN APPROVAL OF THE PRESIDENT OF FAIRCHILD SEMICONDUCTOR CORPORATION. As used herein:

1. Life support devices or systems are devices or systems which, (a) are intended for surgical implant into the body, or (b) support or sustain life, and (c) whose failure to perform when properly used in accordance with instructions for use provided in the labeling, can be reasonably expected to result in a significant injury to the user.
2. A critical component in any component of a life support device or system whose failure to perform can be reasonably expected to cause the failure of the life support device or system, or to affect its safety or effectiveness.

www.fairchildsemi.com