

Excellent Integrated System Limited

Stocking Distributor

Click to view price, real time Inventory, Delivery & Lifecycle Information:

[Fairchild Semiconductor](#)
[SFH154](#)

For any questions, you can email us directly:

sales@integrated-circuit.com

Advanced Power MOSFET

SFH154

FEATURES

- Avalanche Rugged Technology
- Rugged Gate Oxide Technology
- Lower Input Capacitance
- Improved Gate Charge
- Extended Safe Operating Area
- 150°C Operating Temperature
- Lower Leakage Current : 10 μ A (Max.) @ $V_{DS} = 150V$
- Lower $R_{DS(ON)}$: 0.064 Ω (Typ.)

$$BV_{DSS} = 150 V$$

$$R_{DS(on)} = 0.075 \Omega$$

$$I_D = 34 A$$

TO-3P

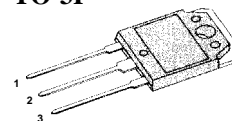

1.Gate 2. Drain 3. Source

Absolute Maximum Ratings

Symbol	Characteristic	Value	Units
V_{DSS}	Drain-to-Source Voltage	150	V
I_D	Continuous Drain Current ($T_C=25^\circ C$)	34	A
	Continuous Drain Current ($T_C=100^\circ C$)	21.6	
I_{DM}	Drain Current-Pulsed ①	136	A
V_{GS}	Gate-to-Source Voltage	± 30	V
E_{AS}	Single Pulsed Avalanche Energy ②	867	mJ
I_{AR}	Avalanche Current ①	34	A
E_{AR}	Repetitive Avalanche Energy ①	20.4	mJ
dv/dt	Peak Diode Recovery dv/dt ③	5.0	V/ns
P_D	Total Power Dissipation ($T_C=25^\circ C$)	204	W
	Linear Derating Factor	1.63	
T_J, T_{STG}	Operating Junction and Storage Temperature Range	- 55 to +150	$^\circ C$
T_L	Maximum Lead Temp. for Soldering Purposes, 1/8 " from case for 5-seconds	300	

Thermal Resistance

Symbol	Characteristic	Typ.	Max.	Units
$R_{\theta JC}$	Junction-to-Case	--	0.61	$^\circ C/W$
$R_{\theta CS}$	Case-to-Sink	0.24	--	
$R_{\theta JA}$	Junction-to-Ambient	--	40	

SFH154

N-CHANNEL POWER MOSFET

Electrical Characteristics (T_C=25°C unless otherwise specified)

Symbol	Characteristic	Min.	Typ.	Max.	Units	Test Condition
BV _{DSS}	Drain-Source Breakdown Voltage	150	--	--	V	V _{GS} =0V, I _D =250μA
ΔBV/ΔT _J	Breakdown Voltage Temp. Coeff.	--	0.11	--	V/°C	I _D =250μA See Fig 7
V _{GS(th)}	Gate Threshold Voltage	2.0	--	4.0	V	V _{DS} =5V, I _D =250μA
I _{GSS}	Gate-Source Leakage, Forward	--	--	100	nA	V _{GS} =20V
	Gate-Source Leakage, Reverse	--	--	-100		V _{GS} =-20V
I _{DSS}	Drain-to-Source Leakage Current	--	--	10	μA	V _{DS} =150V
		--	--	100		V _{DS} =120V, T _C =125°C
R _{DS(on)}	Static Drain-Source On-State Resistance	--	--	0.075	Ω	V _{GS} =10V, I _D =17A ④
g _{fs}	Forward Transconductance	--	20	--	Ω	V _{DS} =40V, I _D =17A ④
C _{iss}	Input Capacitance	--	2590	3370	pF	V _{GS} =0V, V _{DS} =25V, f=1MHz See Fig 5
C _{oss}	Output Capacitance	--	380	450		
C _{rss}	Reverse Transfer Capacitance	--	135	200		
t _{d(on)}	Turn-On Delay Time	--	20	50	ns	V _{DD} =75V, I _D =34A, R _G =6.2Ω See Fig 13 ④ ⑤
t _r	Rise Time	--	25	60		
t _{d(off)}	Turn-Off Delay Time	--	70	145		
t _f	Fall Time	--	30	70		
Q _g	Total Gate Charge	--	90	110	nC	V _{DS} =120V, V _{GS} =10V, I _D =34A See Fig 6 & Fig 12 ④ ⑤
Q _{gs}	Gate-Source Charge	--	20	--		
Q _{gd}	Gate-Drain(" Miller ") Charge	--	35	--		

Source-Drain Diode Ratings and Characteristics

Symbol	Characteristic	Min.	Typ.	Max.	Units	Test Condition
I _S	Continuous Source Current	--	--	34	A	Integral reverse pn-diode in the MOSFET
I _{SM}	Pulsed-Source Current ①	--	--	136		
V _{SD}	Diode Forward Voltage ④	--	--	1.5	V	T _J =25°C, I _S =34A, V _{GS} =0V
t _{rr}	Reverse Recovery Time	--	203	--	ns	T _J =25°C, I _F =34A
Q _{rr}	Reverse Recovery Charge	--	1.52	--	μC	di _F /dt=100A/μs ④

Notes ;

- ① Repetitive Rating : Pulse Width Limited by Maximum Junction Temperature
- ② L=1.0mH, I_{AS}=34A, V_{DD}=50V, R_G=27Ω, Starting T_J=25°C
- ③ I_{SD}≤34A, di/dt≤400A/μs, V_{DD}≤BV_{DSS}, Starting T_J=25°C
- ④ Pulse Test : Pulse Width = 250μs, Duty Cycle ≤ 2%
- ⑤ Essentially Independent of Operating Temperature

**N-CHANNEL
POWER MOSFET**

SFH154

Fig 1. Output Characteristics

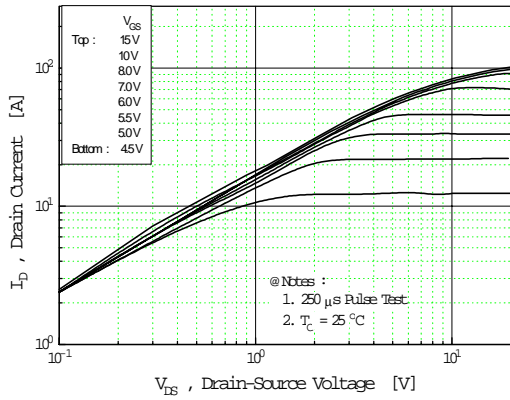

Fig 2. Transfer Characteristics

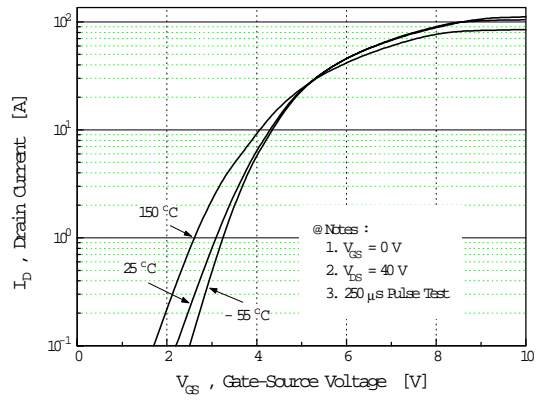

Fig 3. On-Resistance vs. Drain Current

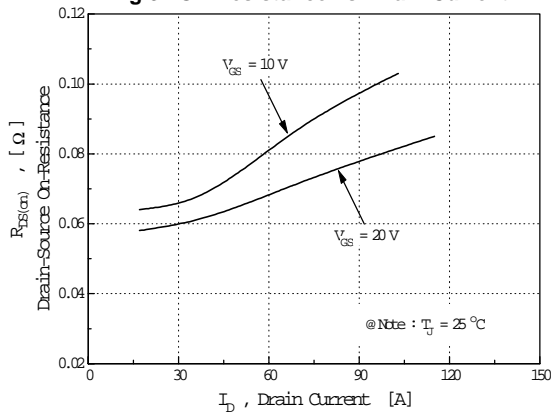

Fig 4. Source-Drain Diode Forward Voltage

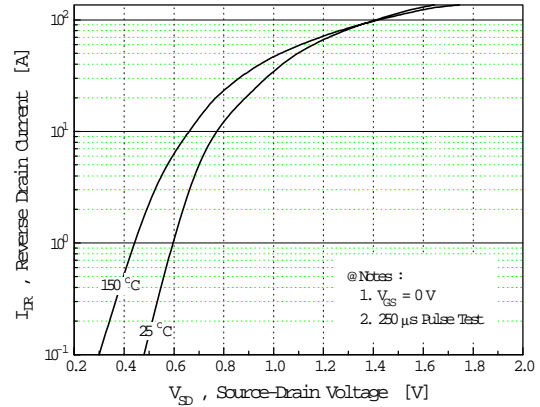

Fig 5. Capacitance vs. Drain-Source Voltage

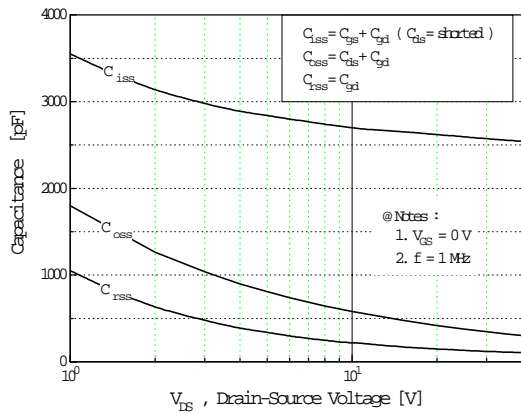
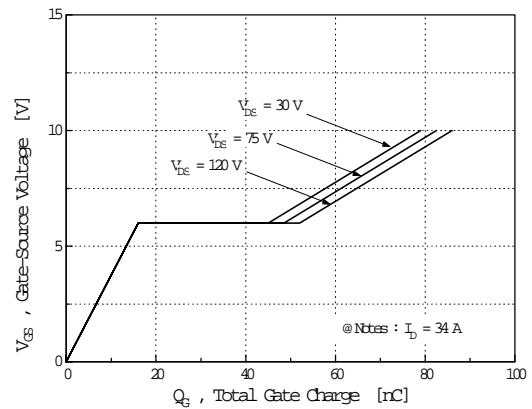

Fig 6. Gate Charge vs. Gate-Source Voltage



SFH154

N-CHANNEL POWER MOSFET

Fig 7. Breakdown Voltage vs. Temperature

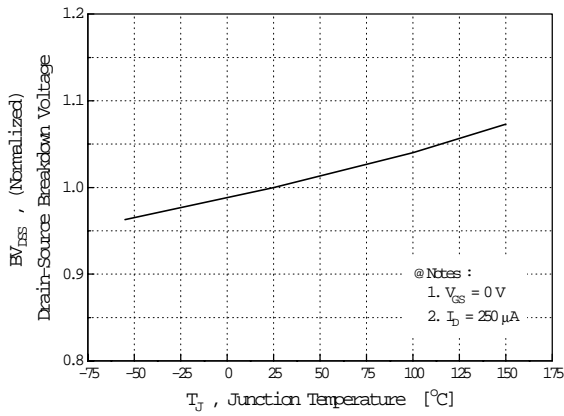

Fig 8. On-Resistance vs. Temperature

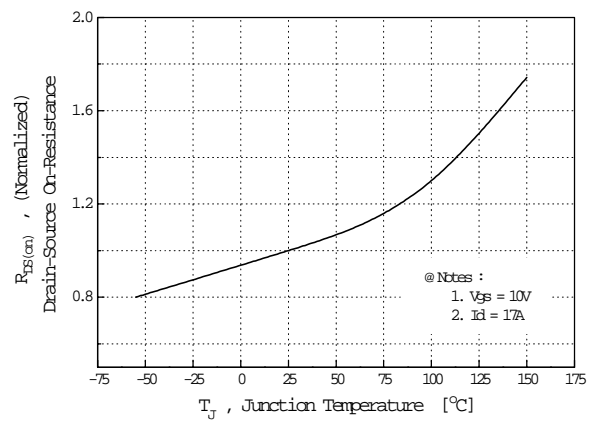

Fig 9. Max. Safe Operating Area

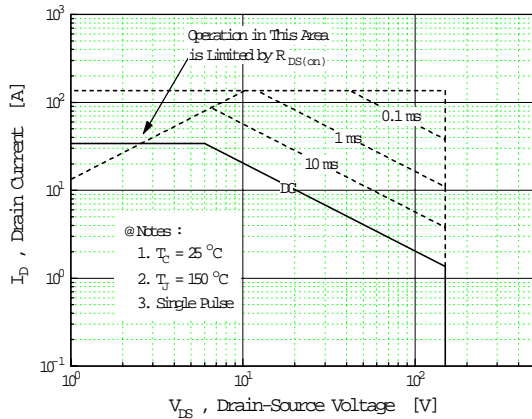

Fig 10. Max. Drain Current vs. Case Temperature

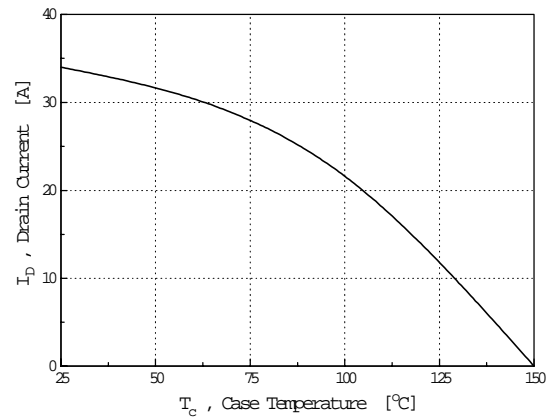
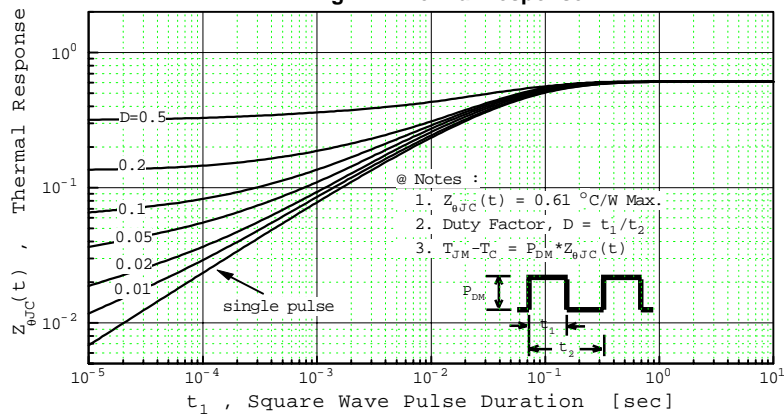

Fig 11. Thermal Response



**N-CHANNEL
POWER MOSFET**

SFH154

Fig 12. Gate Charge Test Circuit & Waveform

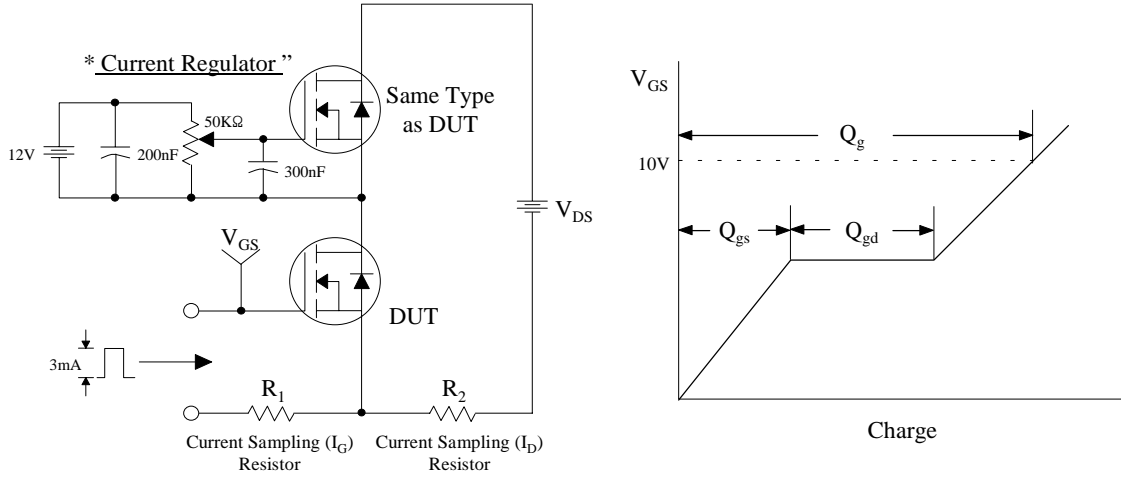

Fig 13. Resistive Switching Test Circuit & Waveforms

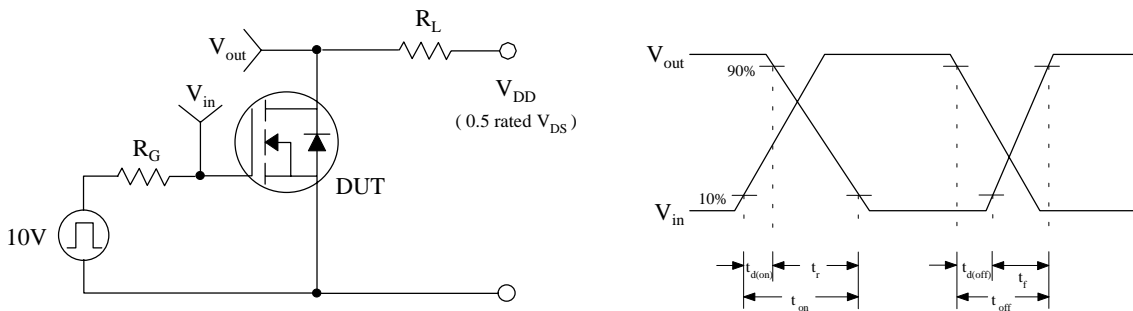
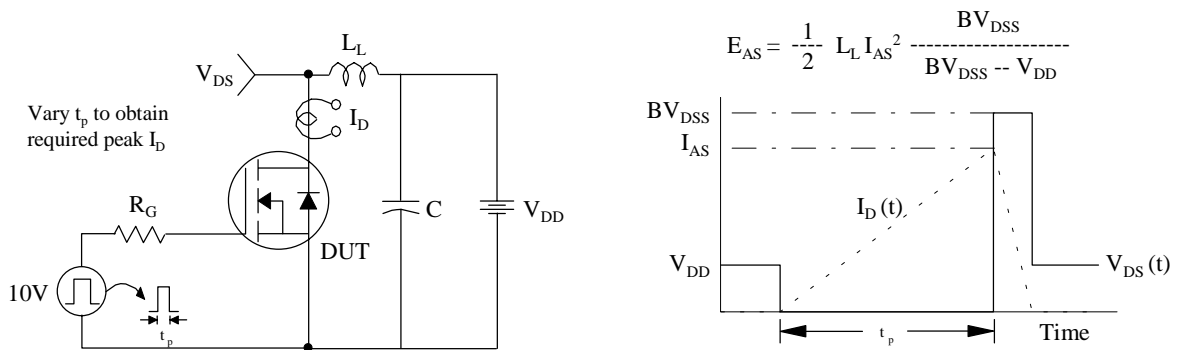

Fig 14. Unclamped Inductive Switching Test Circuit & Waveforms



SFH154

N-CHANNEL POWER MOSFET

Fig 15. Peak Diode Recovery dv/dt Test Circuit & Waveforms

