

Excellent Integrated System Limited

Stocking Distributor

Click to view price, real time Inventory, Delivery & Lifecycle Information:

[Fairchild Semiconductor](#)
[SCAN18374TSSC](#)

For any questions, you can email us directly:
sales@integrated-circuit.com



October 1991
 Revised May 2000

SCAN18374T D-Type Flip-Flop with 3-STATE Outputs

General Description

The SCAN18374T is a high speed, low-power D-type flip-flop featuring separate D-type inputs organized into dual 9-bit bytes with byte-oriented clock and output enable control signals. This device is compliant with IEEE 1149.1 Standard Test Access Port and BOUNDARY-SCAN Architecture with the incorporation of the defined BOUNDARY-SCAN test logic and test access port consisting of Test Data Input (TDI), Test Data Out (TDO), Test Mode Select (TMS), and Test Clock (TCK).

Features

- IEEE 1149.1 (JTAG) Compliant
- Buffered positive edge-triggered clock
- 3-STATE outputs for bus-oriented applications
- 9-bit data busses for parity applications
- Reduced-swing outputs source 32 mA/sink 64 mA
- Guaranteed to drive 50Ω transmission line to TTL input levels of 0.8V and 2.0V
- TTL compatible inputs
- 25 mil pitch SSOP (Shrink Small Outline Package)
- Includes CLAMP and HIGHZ instructions
- Member of Fairchild's SCAN Products

Ordering Code:

Order Number	Package Number	Package Description
SCAN18374TSSC	MS56A	56-Lead Shrink Small Outline Package (SSOP), JEDEC MO-118, 0.300 Wide

Devices also available in Tape and Reel. Specify by appending the suffix letter "X" to the ordering code.

Connection Diagram

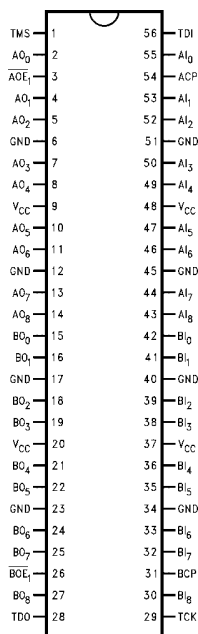

Pin Descriptions

Pin Names	Description
AI ₍₀₋₈₎ , BI ₍₀₋₈₎	Data Inputs
ACP, BCP	Clock Pulse Inputs
AOE ₁ , BOE ₁	3-STATE Output Enable Inputs
AO ₍₀₋₈₎ , BO ₍₀₋₈₎	3-STATE Outputs

Truth Tables

Inputs			AO ₍₀₋₈₎
ACP	AOE ₁	AI ₍₀₋₈₎	
X	H	X	Z
↗	L	L	L
↘	L	H	H

Inputs			BO ₍₀₋₈₎
BCP	BOE ₁	BI ₍₀₋₈₎	
X	H	X	Z
↗	L	L	L
↘	L	H	H

H = HIGH Voltage Level
 L = LOW Voltage Level
 X = Immaterial
 Z = High Impedance
 ↗ = L-to-H Transition

SCAN18374T

Functional Description

The SCAN18374 consists of two sets of nine edge-triggered flip-flops with individual D-type inputs and 3-STATE true outputs. The buffered clock and buffered Output Enable pins are common to all flip-flops. Each set of the nine flip-flops will store the state of their individual D inputs that meet the setup and hold time requirements on the

LOW-to-HIGH Clock (ACP or BCP) transition. With the Output Enable ($\overline{AOE_1}$ or $\overline{BOE_1}$) LOW, the contents of the nine flip-flops are available at the outputs. When the Output Enable is HIGH, the outputs go to the high impedance state. Operation of the Output Enable input does not affect the state of the flip-flops.

Logic Diagram

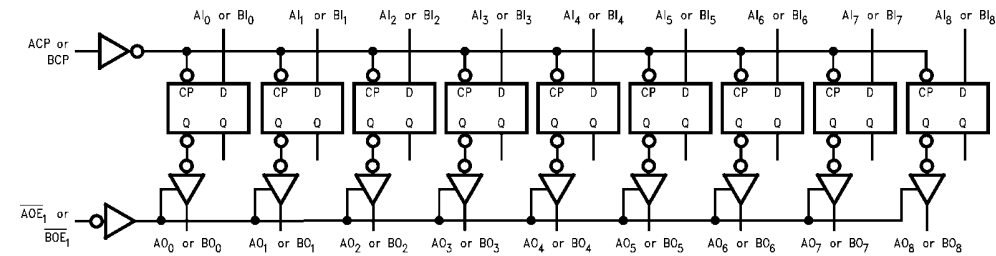

Block Diagrams

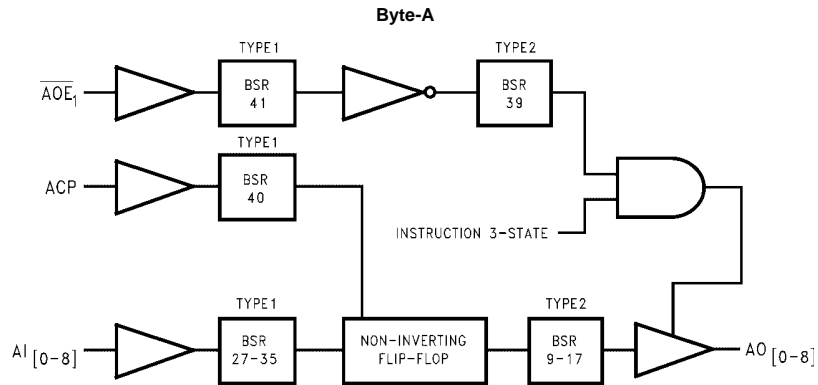

Note: BSR stands for Boundary Scan Register

Block Diagrams (Continued)

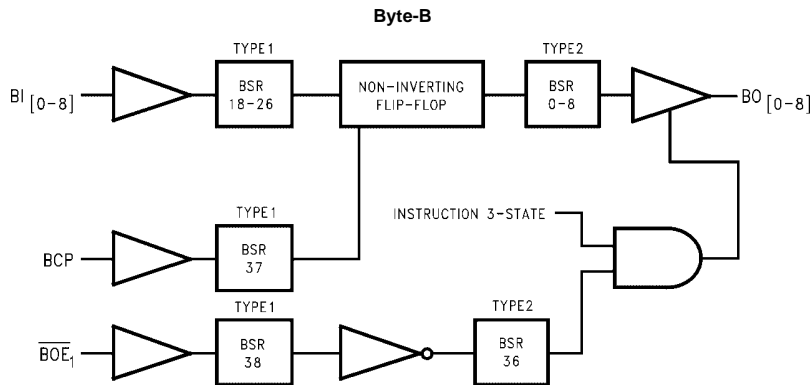
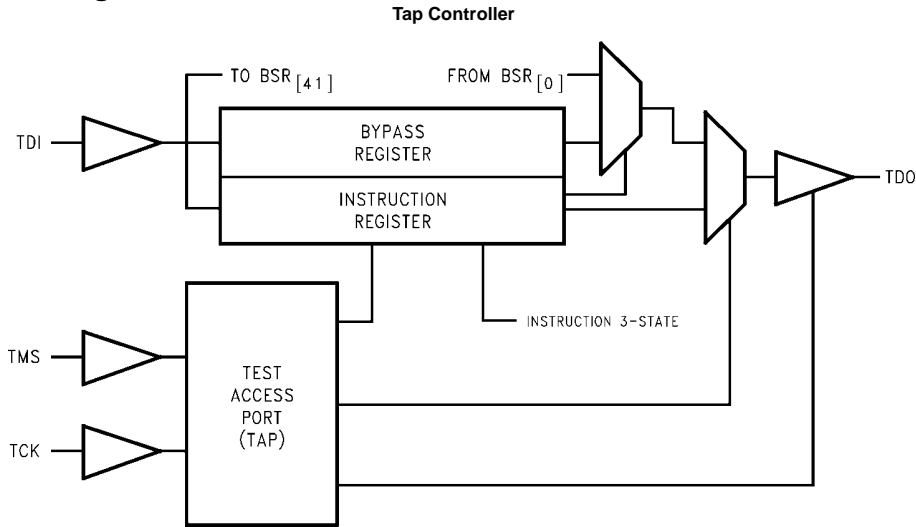

Note: BSR stands for Boundary Scan Register

SCAN18374T

Description of Boundary-Scan Circuitry

The scan cells used in the BOUNDARY-SCAN register are one of the following two types depending upon their location. Scan cell TYPE1 is intended to solely observe system data, while TYPE2 has the additional ability to control system data.

Scan cell TYPE1 is located on each system input pin while scan cell TYPE2 is located at each system output pin as well as at each of the two internal active-high output enable signals. AOE controls the activity of the A-outputs while BOE controls the activity of the B-outputs. Each will activate their respective outputs by loading a logic high.

The BYPASS register is a single bit shift register stage identical to scan cell TYPE1. It captures a fixed logic low.

The two least significant bits of this captured value (01) are required by IEEE Std 1149.1. The upper six bits are unique to the SCAN18374T device. SCAN CMOS Test Access Logic devices do not include the IEEE 1149.1 optional identification register. Therefore, this unique captured value can be used as a "pseudo ID" code to confirm that the correct device is placed in the appropriate location in the boundary scan chain.

Bypass Register Scan Chain Definition
Logic 0

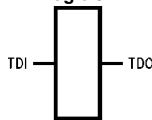

The INSTRUCTION register is an eight-bit register which captures the value 00111101.

Instruction Register Scan Chain Definition

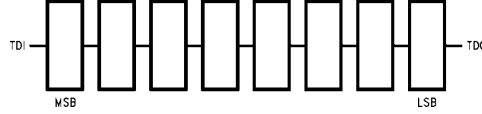

Instruction Code	Instruction
00000000	EXTEST
10000001	SAMPLE/PRELOAD
10000010	CLAMP
00000011	HIGHZ
All Others	BYPASS

Scan Cell TYPE1

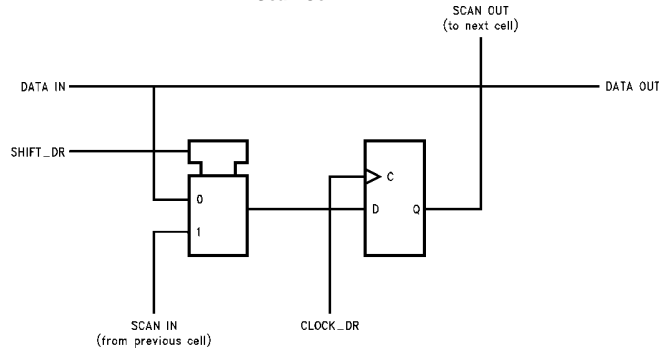

Scan Cell TYPE2

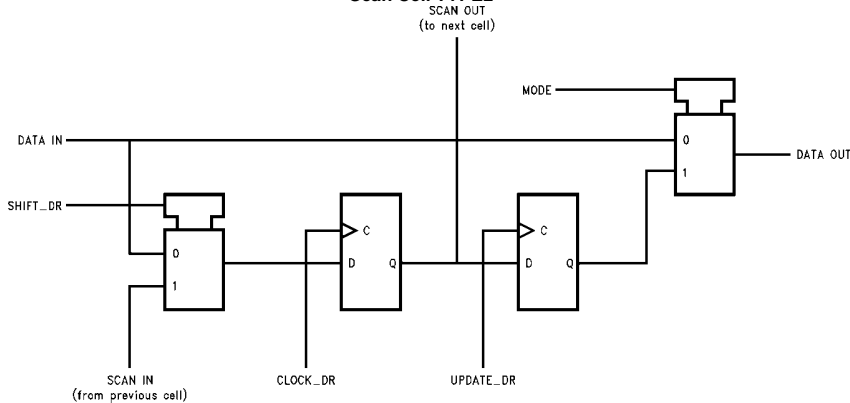

Description of Boundary-Scan Circuitry (Continued)
Boundary-Scan Register
Scan Chain Definition (42 Bits in Length)

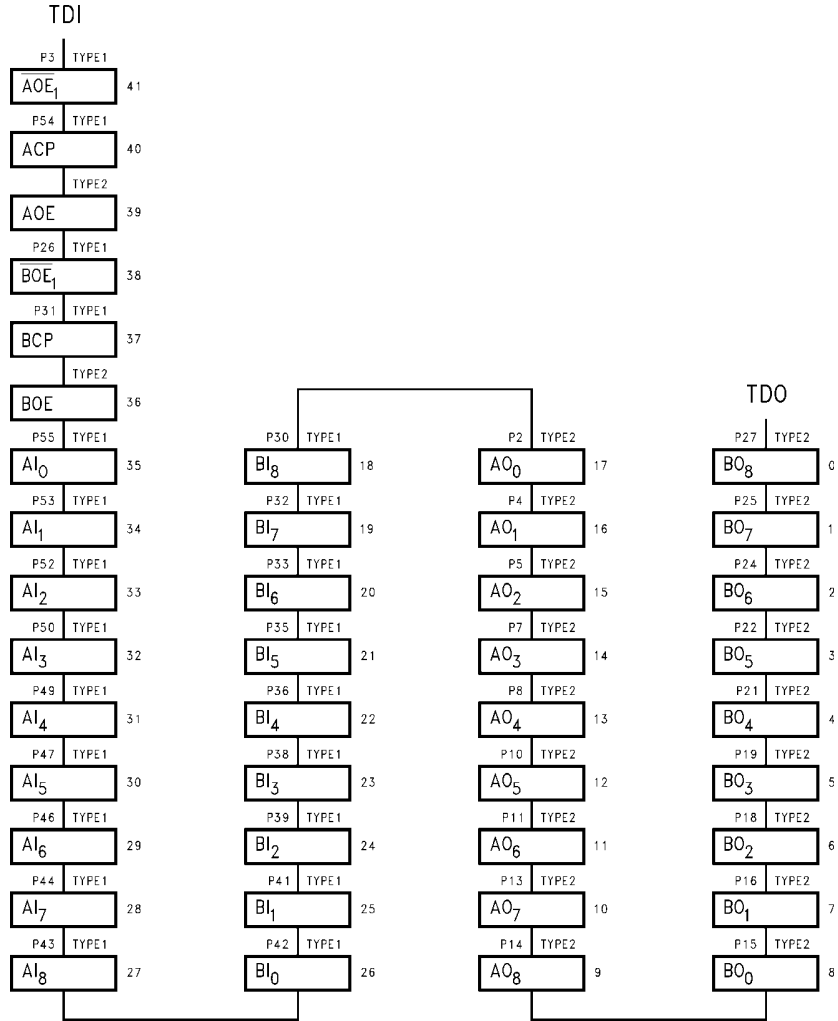

SCAN18374T

Description of Boundary-Scan Circuitry (Continued)

Boundary-Scan Register Definition Index

Bit No.	Pin Name	Pin No.	Pin Type	Scan Cell Type	
41	\overline{AOE}_1	3	Input	TYPE1	Control Signals
40	ACP	54	Input	TYPE1	
39	AOE		Internal	TYPE2	
38	\overline{BOE}_1	26	Input	TYPE1	
37	BCP	31	Input	TYPE1	
36	BOE		Internal	TYPE2	
35	AI ₀	55	Input	TYPE1	A-in
34	AI ₁	53	Input	TYPE1	
33	AI ₂	52	Input	TYPE1	
32	AI ₃	50	Input	TYPE1	
31	AI ₄	49	Input	TYPE1	
30	AI ₅	47	Input	TYPE1	
29	AI ₆	46	Input	TYPE1	
28	AI ₇	44	Input	TYPE1	
27	AI ₈	43	Input	TYPE1	
26	BI ₀	42	Input	TYPE1	B-in
25	BI ₁	41	Input	TYPE1	
24	BI ₂	39	Input	TYPE1	
23	BI ₃	38	Input	TYPE1	
22	BI ₄	36	Input	TYPE1	
21	BI ₅	35	Input	TYPE1	
20	BI ₆	33	Input	TYPE1	
19	BI ₇	32	Input	TYPE1	
18	BI ₈	30	Input	TYPE1	
17	AO ₀	2	Output	TYPE2	A-out
16	AO ₁	4	Output	TYPE2	
15	AO ₂	5	Output	TYPE2	
14	AO ₃	7	Output	TYPE2	
13	AO ₄	8	Output	TYPE2	
12	AO ₅	10	Output	TYPE2	
11	AO ₆	11	Output	TYPE2	
10	AO ₇	13	Output	TYPE2	
9	AO ₈	14	Output	TYPE2	
8	BO ₀	15	Output	TYPE2	B-out
7	BO ₁	16	Output	TYPE2	
6	BO ₂	18	Output	TYPE2	
5	BO ₃	19	Output	TYPE2	
4	BO ₄	21	Output	TYPE2	
3	BO ₅	22	Output	TYPE2	
2	BO ₆	24	Output	TYPE2	
1	BO ₇	25	Output	TYPE2	
0	BO ₈	27	Output	TYPE2	

Absolute Maximum Ratings (Note 1)		Recommended Operating Conditions	
Supply Voltage (V_{CC})	-0.5V to +7.0V	Supply Voltage (V_{CC})	4.5V to 5.5V
DC Input Diode Current (I_{IK})		SCAN Products	0V to V_{CC}
$V_I = -0.5V$	-20 mA	Input Voltage (V_I)	0V to V_{CC}
$V_I = V_{CC} + 0.5V$	+20 mA	Output Voltage (V_O)	0V to V_{CC}
DC Output Diode Current (I_{OK})		Operating Temperature (T_A)	-40°C to +85°C
$V_O = -0.5V$	-20 mA	Minimum Input Edge Rate $\Delta V/\Delta t$	125 mV/ns
$V_O = V_{CC} + 0.5V$	+20 mA	V_{IN} from 0.8V to 2.0V	
DC Output Voltage (V_O)	-0.5V to $V_{CC} + 0.5V$	V_{CC} @ 4.5V, 5.5V	
DC Output Source/Sink Current (I_O)	± 70 mA		
DC V_{CC} or Ground Current			
Per Output Pin	± 70 mA		
Junction Temperature			
SSOP	+140°C		
Storage Temperature	-65°C to +150°C		
ESD (Min)	2000V		

Note 1: Absolute maximum ratings are those values beyond which damage to the device may occur. The databook specifications should be met, without exception, to ensure that the system design is reliable over its power supply, temperature, and output/input loading variables. Fairchild does not recommend operation of SCAN circuits outside databook specifications.

DC Electrical Characteristics

Symbol	Parameter	V_{CC} (V)	$T_A = +25^\circ\text{C}$		$T_A = -40^\circ\text{C to } +85^\circ\text{C}$		Units	Conditions
			Typ	Guaranteed Limits				
V_{IH}	Minimum HIGH Input Voltage	4.5	1.5	2.0	2.0	V	$V_{OUT} = 0.1V$ or $V_{CC} - 0.1V$	
		5.5	1.5	2.0	2.0			
V_{IL}	Maximum LOW Input Voltage	4.5	1.5	0.8	0.8	V	$V_{OUT} = 0.1V$ or $V_{CC} - 0.1V$	
		5.5	1.5	0.8	0.8			
V_{OH}	Minimum HIGH Output Voltage (Note 2)	4.5		3.15	3.15	V	$I_{OUT} = -50 \mu A$	
		5.5		4.15	4.15			
		4.5		2.4	2.4	V	$V_{IN} = V_{IL}$ or V_{IH} $I_{OH} = -32 \text{ mA}$	
		5.5		2.4	2.4			
		4.5		2.4		V	$V_{IN} = V_{IL}$ or V_{IH} $I_{OH} = -24 \text{ mA}$	
		5.5		2.4				
V_{OL}	Maximum LOW Output Voltage (Note 2)	4.5		0.1	0.1	V	$I_{OUT} = 50 \mu A$	
		5.5		0.1	0.1			
		4.5		0.55	0.55	V	$V_{IN} = V_{IL}$ or V_{IH} $I_{OL} = 64 \text{ mA}$	
		5.5		0.55	0.55			
		4.5		0.55		V	$V_{IN} = V_{IL}$ or V_{IH} $I_{OL} = 48 \text{ mA}$	
		5.5		0.55				
I_{IN}	Maximum Input Leakage Current	5.5		± 0.1	± 1.0	μA	$V_I = V_{CC}, \text{ GND}$	
I_{IN} TDI, TMS	Maximum Input Leakage	5.5		2.8	3.6	μA	$V_I = V_{CC}$	
				-385	-385	μA	$V_I = \text{GND}$	
	Minimum Input Leakage	5.5		-160	-160	μA	$V_I = \text{GND}$	
I_{OLD}	Minimum Dynamic	5.5		94	94	mA	$V_{OLD} = 0.8V \text{ Max}$	
I_{OHD}	Output Current (Note 3)			-40	-40	mA	$V_{OHD} = 2.0V \text{ Min}$	
I_{OZ}	Maximum Output Leakage Current	5.5		± 0.5	± 5.0	μA	$V_I (\text{OE}) = V_{IL}, V_{IH}$	
I_{OS}	Output Short Circuit Current	5.5		-100	-100	mA (min)	$V_O = 0V$	
I_{CC}	Maximum Quiescent Supply Current	5.5		16.0	88	μA	$V_O = \text{Open}$ TDI, TMS = V_{CC}	
		5.5		750	820	μA	$V_O = \text{Open}$ TDI, TMS = GND	

SCAN18374T

DC Electrical Characteristics (Continued)								
Symbol	Parameter	V _{CC} (V)	T _A = +25°C		T _A = -40°C to +85°C		Units	Conditions
			Typ	Guaranteed Limits				
I _{CC1}	Maximum I _{CC} Per Input	5.5		2.0	2.0		mA	V _I = V _{CC} - 2.1V
		5.5		2.15	2.15		mA	V _I = V _{CC} - 2.1V TDI/TMS Pin, Test One with the Other Floating
<p>Note 2: All outputs loaded; thresholds associated with output under test. Note 3: Maximum test duration 2.0 ms, one output loaded at a time.</p>								
Noise Specifications								
Symbol	Parameter	V _{CC} (V)	T _A = +25°C		T _A = -40°C to +85°C		Units	
			Typ	Guaranteed Limits				
V _{OLP}	Maximum HIGH Output Noise (Note 5)(Note 6)	5.0	1.0	1.5			V	
V _{OLV}	Minimum LOW Output Noise (Note 5)(Note 6)	5.0	-0.6	-1.2			V	
V _{OHP}	Maximum Overshoot (Note 4)(Note 6)	5.0	V _{OH} +1.0	V _{OH} +1.5			V	
V _{OHV}	Minimum V _{CC} Droop (Note 4)(Note 6)	5.0	V _{OH} -1.0	V _{OH} -1.8			V	
V _{IHD}	Minimum HIGH Dynamic Input Voltage Level (Note 4)(Note 7)	5.5	1.6	2.0	2.0		V	
V _{ILD}	Maximum LOW Dynamic Input Voltage Level (Note 4)(Note 7)	5.5	1.4	0.8	0.8		V	
<p>Note 4: Worst case package. Note 5: Maximum number of outputs that can switch simultaneously is n. (n - 1) outputs are switched LOW and one output held LOW. Note 6: Maximum number of outputs that can switch simultaneously is n. (n - 1) outputs are switched HIGH and one output held HIGH. Note 7: Maximum number of data inputs (n) switching. (n - 1) input switching 0V to 3V. Input under test switching 3V to threshold (V_{ILD}).</p>								
AC Electrical Characteristics								
Symbol	Parameter	V _{CC} (V) (Note 8)	T _A = +25°C C _L = 50 pF			T _A = -40°C to +85°C C _L = 50 pF		Units
			Min	Typ	Max	Min	Max	
t _{PLH}	Propagation Delay CP to Q	5.0	2.5		9.5	2.5	10.5	ns
t _{PHL}			2.5		10.3	2.5	11.5	
t _{PLZ}	Disable Time	5.0	1.5		9.0	1.5	9.5	ns
t _{PHZ}			1.5		9.0	1.5	10.0	
t _{PZL}	Enable Time	5.0	2.0		10.9	2.0	12.0	ns
t _{PZH}			2.0		8.9	2.0	9.5	
<p>Note 8: Voltage Range 5.0 is 5.0V ± 0.5V.</p>								
AC Operating Requirements								
Normal Operation								
Symbol	Parameter	V _{CC} (V) (Note 9)	T _A = +25°C C _L = 50 pF		T _A = -40°C to +85°C C _L = 50 pF		Units	
			Guaranteed Minimum					
t _S	Setup Time, H or L Data to CP	5.0	3.0		3.0		ns	
t _H	Hold Time, H or L CP to Data	5.0	1.5		1.5		ns	
t _W	CP Pulse Width	5.0	5.0		5.0		ns	
f _{MAX}	Maximum ACP/BCP Clock Frequency	5.0	100		90		MHz	
<p>Note 9: Voltage Range 5.0 is 5.0V ± 0.5V.</p>								

AC Electrical Characteristics								
Scan Test Operation								
Symbol	Parameter	V _{CC} (V) (Note 10)	T _A = +25°C C _L = 50 pF			T _A = -40°C to +85°C C _L = 50 pF		Units
			Min	Typ	Max	Min	Max	
t _{PLH} , t _{PHL}	Propagation Delay TCK to TDO	5.0	3.5		13.2	3.5	14.5	ns
t _{PLZ} , t _{PHZ}	Disable Time TCK to TDO	5.0	2.5		11.5	2.5	11.9	ns
t _{PZL} , t _{PZH}	Enable Time TCK to TDO	5.0	3.0		14.5	3.0	15.8	ns
t _{PLH} , t _{PHL}	Propagation Delay TCK to Data Out During Update-DR State	5.0	5.0		18.0	5.0	19.8	ns
t _{PLH} , t _{PHL}	Propagation Delay TCK to Data Out During Update-IR State	5.0	5.0		18.6	5.0	20.2	ns
t _{PLH} , t _{PHL}	Propagation Delay TCK to Data Out During Test Logic Reset State	5.0	5.5		19.9	5.5	21.5	ns
t _{PLZ} , t _{PHZ}	Propagation Delay TCK to Data Out During Update-DR State	5.0	4.0		16.4	4.0	18.2	ns
t _{PLZ} , t _{PHZ}	Propagation Delay TCK to Data Out During Update-IR State	5.0	5.0		19.5	5.0	20.8	ns
t _{PLZ} , t _{PHZ}	Propagation Delay TCK to Data Out During Test Logic Reset State	5.0	5.0		19.9	5.0	21.5	ns
t _{PZL} , t _{PZH}	Propagation Delay TCK to Data Out During Update-DR State	5.0	5.0		18.9	5.0	20.9	ns
t _{PZL} , t _{PZH}	Propagation Delay TCK to Data Out During Update-IR State	5.0	6.5		22.4	6.5	24.2	ns
t _{PZL} , t _{PZH}	Propagation Delay TCK to Data Out During Test Logic Reset State	5.0	7.0		23.8	7.0	25.7	ns

Note 10: Voltage Range 5.0 is 5.0V ± 0.5V.
Note: All Propagation Delays involving TCK are measured from the falling edge of TCK.

SCAN18374T

AC Operating Requirements					
Scan Test Operation					
Symbol	Parameter	V _{CC} (V) (Note 11)	T _A = +25°C	T _A = -40°C to +85°C	Units
			C _L = 50 pF	C _L = 50 pF	
			Guaranteed Minimum		
t _S	Setup Time, H or L Data to TCK (Note 12)	5.0	3.0	3.0	ns
t _H	Hold Time, H or L TCK to Data (Note 12)	5.0	4.5	4.5	ns
t _S	Setup Time, H or L AOE _T , BOE _T to TCK (Note 13)	5.0	3.0	3.0	ns
t _H	Hold Time, H or L TCK to AOE _T , BOE _T (Note 13)	5.0	4.5	4.5	ns
t _S	Setup Time, H or L Internal AOE, BOE to TCK (Note 14)	5.0	3.0	3.0	ns
t _H	Hold Time, H or L TCK to Internal AOE, BOE (Note 14)	5.0	3.0	3.0	ns
t _S	Setup Time ACP, BCP (Note 15) to TCK	5.0	3.0	3.0	ns
t _H	Hold Time TCK to ACP, BCP (Note 15)	5.0	3.5	3.5	ns
t _S	Setup Time, H or L TMS to TCK	5.0	8.0	8.0	ns
t _H	Hold Time, H or L TCK to TMS	5.0	2.0	2.0	ns
t _S	Setup Time, H or L TDI to TCK	5.0	4.0	4.0	ns
t _H	Hold Time, H or L TCK to TDI	5.0	4.5	4.5	ns
t _W	Pulse Width TCK	5.0	H	15.0	ns
			L	5.0	ns
f _{MAX}	Maximum TCK Clock Frequency	5.0	25	25	MHz
T _{pu}	Wait Time, Power Up to TCK	5.0	100	100	ns
T _{dn}	Power Down Delay	0.0	100	100	ms

Note 11: Voltage Range 5.0 is 5.0V ± 0.5V.

Note 12: This delay represents the timing relationship between the data Input and TCK at the associated scan cells numbered 0–8, 9–17, 18–26 and 27–35.

Note 13: Timing pertains to BSR 38 and 41 only.

Note 14: This delay represents the timing relationship between AOE, BOE and TCK at scan cells 36 and 39 only.

Note 15: Timing pertains to BSR 37 and 40 only.

Note: All Input Timing Delays involving TCK are measured from the rising edge of TCK.

Extended AC Electrical Characteristics							
Symbol	Parameter	T _A = +25°C V _{CC} = 5.0V C _L = 50 pF 18 Outputs Switching (Note 16)			T _A = -40°C to +85°C V _{CC} = 5.0V ± 0.5V C _L = 250 pF (Note 17)		Units
		Min	Typ	Max	Min	Max	
t _{PLH}	Propagation Delay	3.0		11.5	4.0	13.5	ns
t _{PHL}	Data to Output	3.0		12.5	4.0	16.5	
t _{PZH}	Output Enable Time	2.5		10.5	(Note 18)		ns
t _{PZL}				2.5			
t _{PHZ}	Output Disable Time	2.0		10.5	(Note 19)		ns
t _{PLZ}				10.5			
t _{OSSL} (Note 20)	Pin to Pin Skew HL Data to Output		0.5	1.0		1.0	ns
t _{OSSLH} (Note 20)	Pin to Pin Skew LH Data to Output		0.5	1.0		1.0	ns

Note 16: This specification is guaranteed but not tested. The limits apply to propagation delays for all paths described switching in phase (i.e., all LOW-to-HIGH, HIGH-to-LOW, etc.).

Note 17: This specification is guaranteed but not tested. The limits represent propagation delays with 250 pF load capacitors in place of the 50 pF load capacitors in the standard AC load. This specification pertains to single output switching only.

Note 18: 3-STATE delays are load dominated and have been excluded from the datasheet.

Note 19: The Output Disable Time is dominated by the RC network (500Ω, 250 pF) on the output and has been excluded from the datasheet.

Note 20: Skew is defined as the absolute value of the difference between the actual propagation delays for any two separate outputs of the same device. The specification applies to any outputs switching HIGH-to-LOW (t_{OSSL}), LOW-to-HIGH (t_{OSSLH}), or any combination switching LOW-to-HIGH and/or HIGH-to-LOW.

Capacitance

Symbol	Parameter	Typ	Units	Conditions
C _{IN}	Input Pin Capacitance	4.0	pF	V _{CC} = 5.0V
C _{OUT}	Output Pin Capacitance	13.0	pF	V _{CC} = 5.0V
C _{PD}	Power Dissipation Capacitance	34.0	pF	V _{CC} = 5.0V

SCAN18374T D-Type Flip-Flop with 3-STATE Outputs

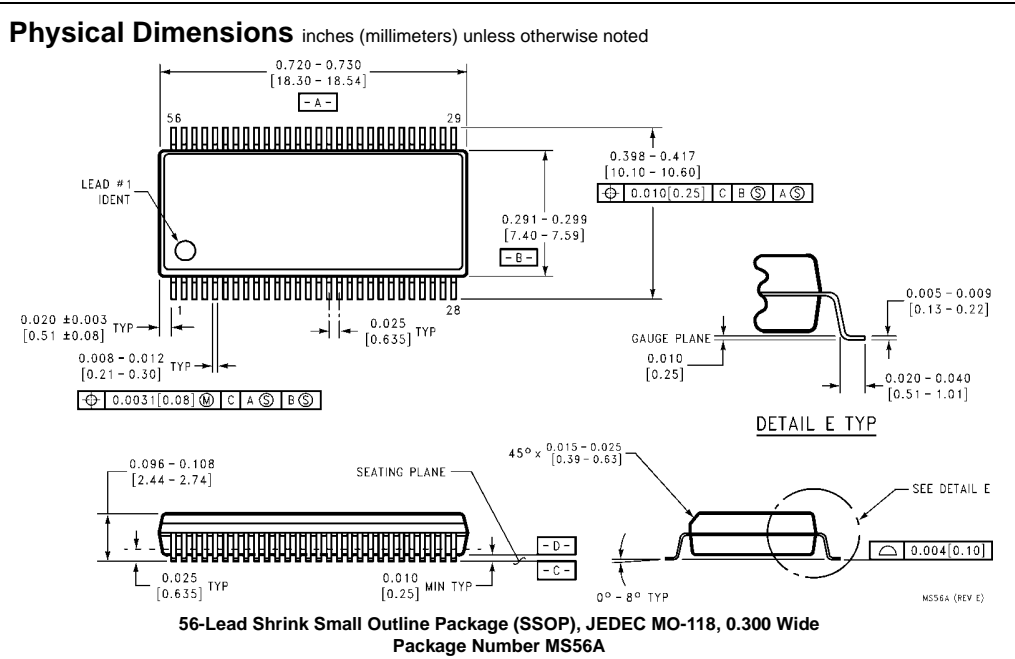

Fairchild does not assume any responsibility for use of any circuitry described, no circuit patent licenses are implied and Fairchild reserves the right at any time without notice to change said circuitry and specifications.

LIFE SUPPORT POLICY

FAIRCHILD'S PRODUCTS ARE NOT AUTHORIZED FOR USE AS CRITICAL COMPONENTS IN LIFE SUPPORT DEVICES OR SYSTEMS WITHOUT THE EXPRESS WRITTEN APPROVAL OF THE PRESIDENT OF FAIRCHILD SEMICONDUCTOR CORPORATION. As used herein:

1. Life support devices or systems are devices or systems which, (a) are intended for surgical implant into the body, or (b) support or sustain life, and (c) whose failure to perform when properly used in accordance with instructions for use provided in the labeling, can be reasonably expected to result in a significant injury to the user.
2. A critical component in any component of a life support device or system whose failure to perform can be reasonably expected to cause the failure of the life support device or system, or to affect its safety or effectiveness.

www.fairchildsemi.com