

Excellent Integrated System Limited

Stocking Distributor

Click to view price, real time Inventory, Delivery & Lifecycle Information:

[NXP Semiconductors/Freescale Semiconductor, Inc.](#)
[TDA6120Q/N2,112](#)

For any questions, you can email us directly:

sales@integrated-circuit.com

INTEGRATED CIRCUITS

DATA SHEET

TDA6120Q Video output amplifier

Product specification
 Supersedes data of 2000 Apr 19
 File under Integrated Circuits, IC02

2000 Dec 13

Video output amplifier

TDA6120Q

FEATURES

- High large-signal bandwidth of 32 MHz (typ.) at 125 V (p-p)
- High small-signal bandwidth of 47 MHz (typ.) at 60 V (p-p)
- Rise/fall time of 12.5 ns for 125 V (p-p)
- High slew rate of 10 V/ns
- Low static power dissipation of 2.6 W at 200 V supply voltage
- High maximum output voltage
- Bandwidth independent of voltage gain

- Maximum overall voltage gain over 46 dB
- High Power Supply Rejection Ratio (PSRR)
- Fast cathode current measurement output for dark current control loop
- Differential voltage input.

GENERAL DESCRIPTION

The TDA6120Q is a single 32 MHz, 125 V (p-p) video output amplifier contained in a plastic DIL-bent-SIL power package. The device uses high-voltage DMOS technology and is intended to drive the cathodes of a CRT in High Definition TVs (HDTVs) or monitors.

ORDERING INFORMATION

TYPE NUMBER	PACKAGE		
	NAME	DESCRIPTION	VERSION
TDA6120Q	DBS13P	plastic DIL-bent-SIL power package; 13 leads (lead length 7.7 mm)	SOT141-8

Video output amplifier

TDA6120Q

BLOCK DIAGRAM

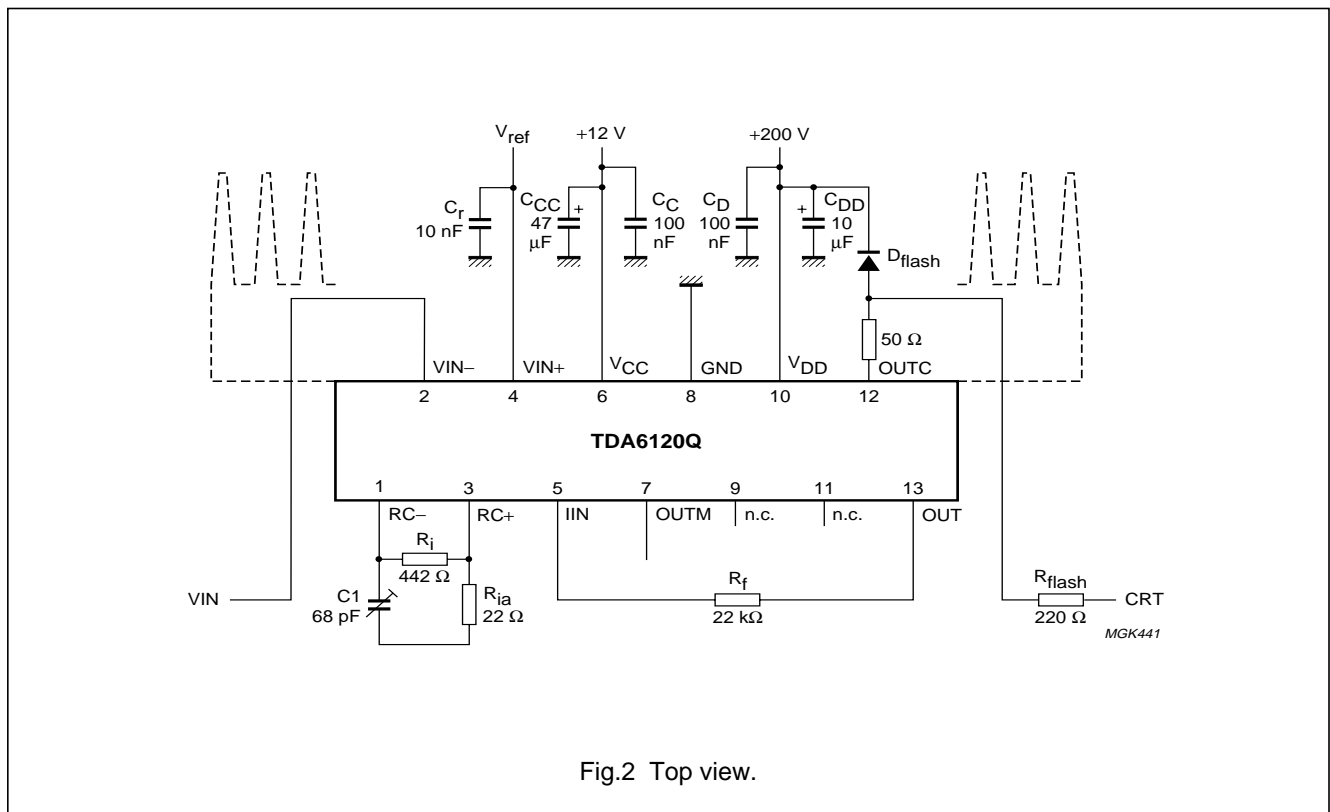
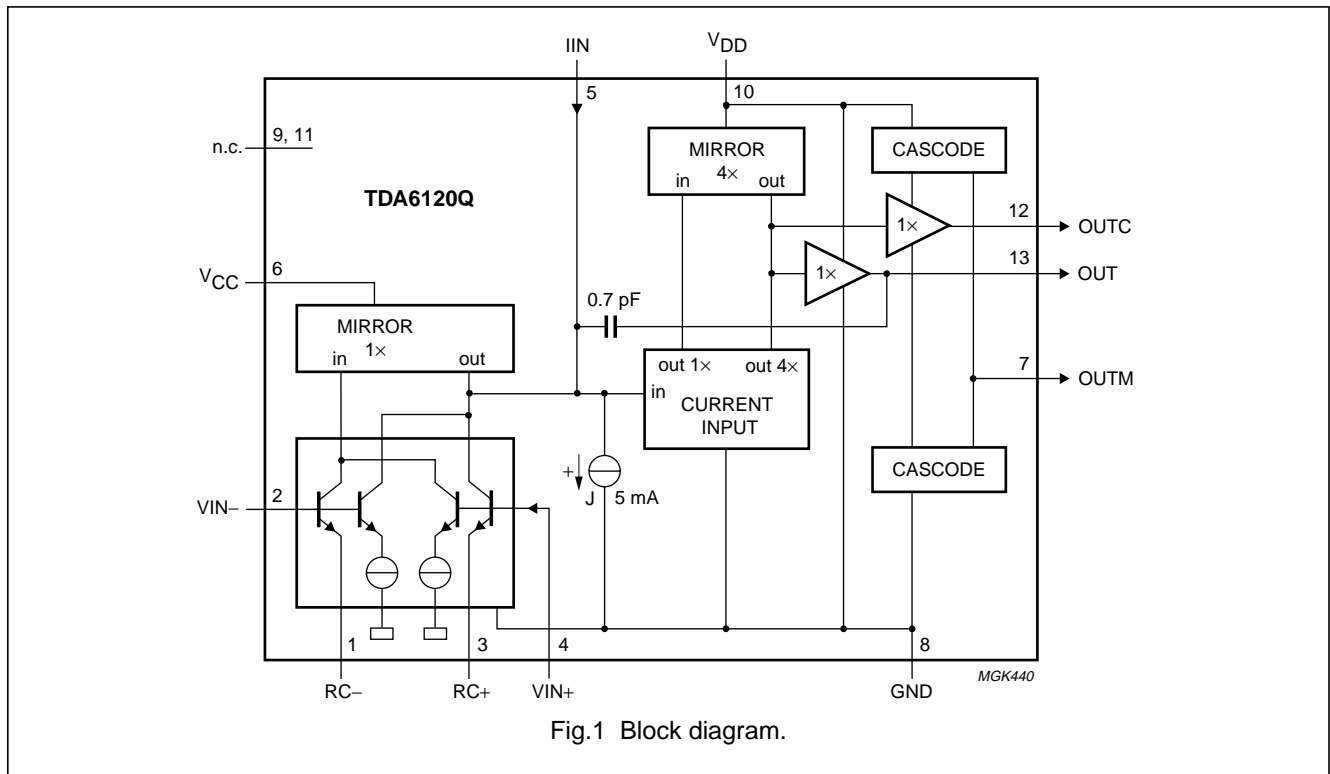

Video output amplifier

TDA6120Q

PINNING

SYMBOL	PIN	DESCRIPTION
RC-	1	inverting input pre-emphasis network
VIN-	2	inverting voltage input
RC+	3	non-inverting input pre-emphasis network
VIN+	4	non-inverting voltage input
IIN	5	feedback current input
V _{CC}	6	low supply voltage (12 V)
OUTM	7	cathode current measurement output
GND	8	power ground
n.c.	9	not connected
V _{DD}	10	high supply voltage (200 V)
n.c.	11	not connected
OUTC	12	cathode output
OUT	13	feedback output

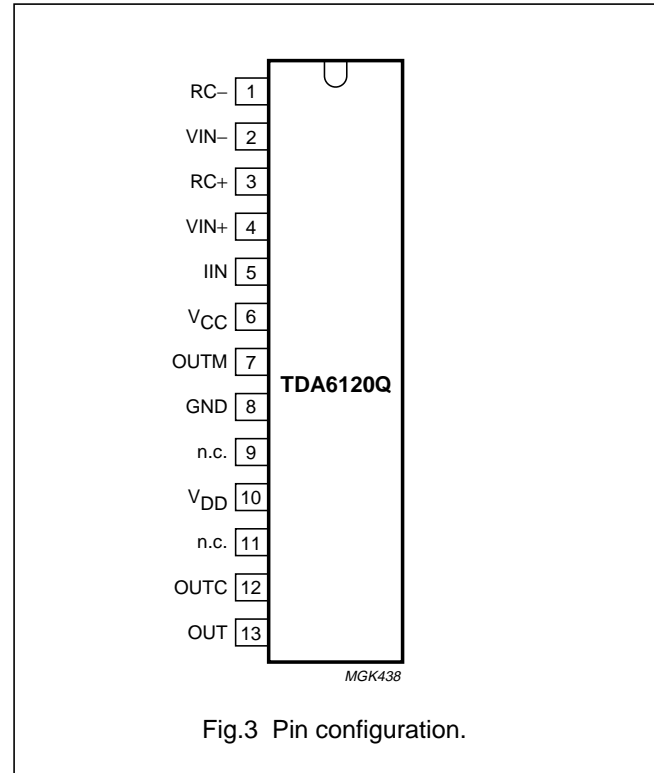

Fig.3 Pin configuration.

LIMITING VALUES

In accordance with the Absolute Maximum Rating System (IEC 60134).

SYMBOL	PARAMETER	MIN.	MAX.	UNIT
V _{DD}	high supply voltage	0	280	V
V _{CC}	low supply voltage	0	20	V
V _i	input voltage (pins 2 and 4)	0	V _{CC}	V
V _{i(dif)}	differential mode input voltage (pins 2 and 4)	-V _{CC}	+V _{CC}	V
V _{i(pe)}	pre-emphasis input voltage (pins 1 and 3)	0	V _{CC}	V
V _{i(dif)(pe)}	differential mode pre-emphasis input voltage (pins 1 and 3)	-V _{CC}	+V _{CC}	V
V _{IIN}	input voltage (pin 5)	0	2V _{BE}	V
V _{OUTM}	measurement output voltage	0	20	V
V _o	output voltage (pins 12 and 13)	0	V _{DD}	V
T _{stg}	storage temperature	-55	+150	°C
T _j	junction temperature	-20	+150	°C
V _{ESD}	voltage peak human body model	-	2000	V
	voltage peak machine model	-	300	V

Video output amplifier

TDA6120Q

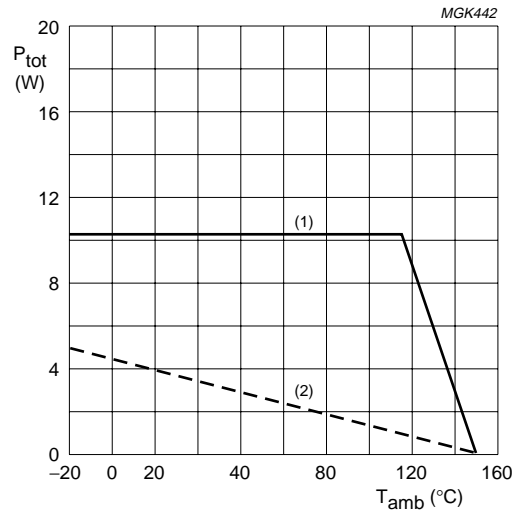

- (1) Infinite heatsink.
- (2) No heatsink.

Fig.4 Power derating curve.

THERMAL CHARACTERISTICS

SYMBOL	PARAMETER	VALUE	UNIT
$R_{th(j-c)}$	thermal resistance from junction to case	3.0	K/W

QUALITY SPECIFICATION

Quality specification in accordance with "SNW-FQ-611 part D".

Video output amplifier

TDA6120Q

CHARACTERISTICS

Operating range: $T_j = -20$ to $+150$ °C; $V_{DD} = 180$ to 210 V; $V_{CC} = 10.8$ to 13.2 V; $V_{OUTM} = 3$ to 16.5 V;
 $V_{VIN-} = 1.5$ to $V_{CC} - 6$ V; $V_{VIN+} = 1.5$ to $V_{CC} - 6$ V. Test conditions: $T_j = 25$ °C; $V_{DD} = 200$ V; $V_{CC} = 12$ V; $V_{VIN+} = 3$ V;
 $V_{OUTM} = 6$ V; $C_L = 10$ pF (C_L consists of parasitic and cathode capacitance); $R_{th(h-a)} = 4$ K/W; test circuit of Fig.5; unless otherwise specified.

SYMBOL	PARAMETER	CONDITIONS	MIN.	TYP.	MAX.	UNIT
$I_{DD(q)}$	quiescent high voltage supply current	$V_{OUTC} = 100$ V	9	11	13	mA
$I_{CC(q)}$	quiescent low voltage supply current	$V_{VIN-} = V_{VIN+}$	35	45	55	mA
I_{bias}	input bias current (pins 2 and 4)	$V_{OUTC} = 100$ V	–	76	–	µA
V_{OUTC}	DC output voltage (pins 12 and 13)	$V_{VIN-} = V_{VIN+}$	85	103	120	V
$\Delta V_{OUTC(T)}$	DC output voltage temperature drift (pins 12 and 13)	$V_{VIN-} = V_{VIN+}$; temperature range 30 °C < T_j < 110 °C	–100	–25	+55	mV/K
$I_{(offset)OUTM}$	offset current of measurement output	note 1	–30	0	+30	µA
$\Delta I_{OUTM}/\Delta I_{OUTC}$	linearity of current transfer	-50 µA < I_{OUTC} < $+50$ µA; note 1	–	1.0	–	
C_i	input capacitance (pins 2 and 4)	$V_{OUTC} = V_{OUTC(max)}$	–	4	–	pF
$I_{OUTC(max)}$	maximum dynamic peak output current (pin 12)	20 V < $V_{OUTC} < V_{DD} - 20$ V	–	100	–	mA
$V_{OUTC(min)}$	minimum output voltage (pin 12)		–	4	10	V
$V_{OUTC(max)}$	maximum output voltage (pin 12)		$V_{DD} - 10$	$V_{DD} - 6$	–	V
$V_{CC(sw)}$	V_{CC} switch level at which pins OUT and OUTC become HIGH		–	8.8	–	V
G_{int}	internal gain		1.68	1.87	2.08	
B_s	small-signal bandwidth (pin 12)	$V_{OUTC(AC)} = 60$ V (p-p); $V_{OUTC(DC)} = 100$ V	40	47	–	MHz
B_l	large-signal bandwidth (pin 12)	$V_{OUTC(AC)} = 125$ V (p-p); $V_{OUTC(DC)} = 100$ V	28	32	–	MHz
t_{pd}	cathode output propagation time 50% input to 50% output (pin 12)	$V_{OUTC(AC)} = 125$ V (p-p); $V_{OUTC(DC)} = 100$ V; square wave; $f < 1$ MHz; $t_{f(VIN-)} = 10$ ns; $t_{r(VIN-)} = 10$ ns; see Figs 6 and 7	10	–	15	ns

Video output amplifier

TDA6120Q

SYMBOL	PARAMETER	CONDITIONS	MIN.	TYP.	MAX.	UNIT
$t_{o(r)}$	cathode output rise time 10% output to 90% output (pin 12)	$V_{OUTC(AC)} = 125\text{ V (p-p)}$; $V_{OUTC(DC)} = 100\text{ V}$; square wave; $f < 1\text{ MHz}$; $t_{f(VIN-)} = 10\text{ ns}$; $t_{r(VIN-)} = 10\text{ ns}$; see Fig.6	10	12.5	18	ns
$t_{o(f)}$	cathode output fall time 90% output to 10% output (pin 12)	$V_{OUTC(AC)} = 125\text{ V (p-p)}$; $V_{OUTC(DC)} = 100\text{ V}$; square wave; $f < 1\text{ MHz}$; $t_{f(VIN-)} = 10\text{ ns}$; $t_{r(VIN-)} = 10\text{ ns}$; see Fig.7	10	12.5	15	ns
t_{st}	settling time 50% input to (99% < output < 101%) (pin 12)	$V_{OUTC(AC)} = 125\text{ V (p-p)}$; $V_{OUTC(DC)} = 100\text{ V}$; square wave $f < 1\text{ MHz}$; $t_{f(VIN-)} = 10\text{ ns}$; $t_{r(VIN-)} = 10\text{ ns}$; see Figs 6 and 7	–	–	350	ns
SR_r	slew rate rise between 30 V to ($V_{DD} - 30\text{ V}$) (pin 12)	$V_{VIN-} = 2\text{ V (p-p)}$; square wave; $f < 1\text{ MHz}$; $t_{f(VIN-)} = 10\text{ ns}$; $t_{r(VIN-)} = 10\text{ ns}$	–	8	–	V/ns
SR_f	slew rate fall between ($V_{DD} - 30\text{ V}$) to 30 V (pin 12)	$V_{VIN-} = 2\text{ V (p-p)}$; square wave; $f < 1\text{ MHz}$; $t_{f(VIN-)} = 10\text{ ns}$; $t_{r(VIN-)} = 10\text{ ns}$	–	10	–	V/ns
O_{Vr}	cathode output voltage overshoot rise (pin 12)	$V_{OUTC(AC)} = 125\text{ V (p-p)}$; $V_{OUTC(DC)} = 100\text{ V}$; square wave; $f < 1\text{ MHz}$; $t_{f(VIN-)} = 10\text{ ns}$; $t_{r(VIN-)} = 10\text{ ns}$; see Figs 6 and 7	–	5	–	%
O_{Vf}	cathode output voltage overshoot fall (pin 12)	$V_{OUTC(AC)} = 125\text{ V (p-p)}$; $V_{OUTC(DC)} = 100\text{ V}$; square wave; $f < 1\text{ MHz}$; $t_{f(VIN-)} = 10\text{ ns}$; $t_{r(VIN-)} = 10\text{ ns}$; see Figs 6 and 7	–	20	–	%
PSRRh	high voltage power supply rejection ratio	$f < 50\text{ kHz}$; note 2	–	44	–	dB
PSRRl	low voltage power supply rejection ratio	$f < 50\text{ kHz}$; note 2	–	48	–	dB

Notes

1. The operating range of the measurement output OUTM is 3 to 16.5 V. Below 3 V, OUTM acts as a voltage source with an output resistance such that the maximum current input from OUTM is 1.25 mA.
2. The ratio of the change in supply voltage to the change in input voltage when there is no change in output voltage.

Video output amplifier

TDA6120Q

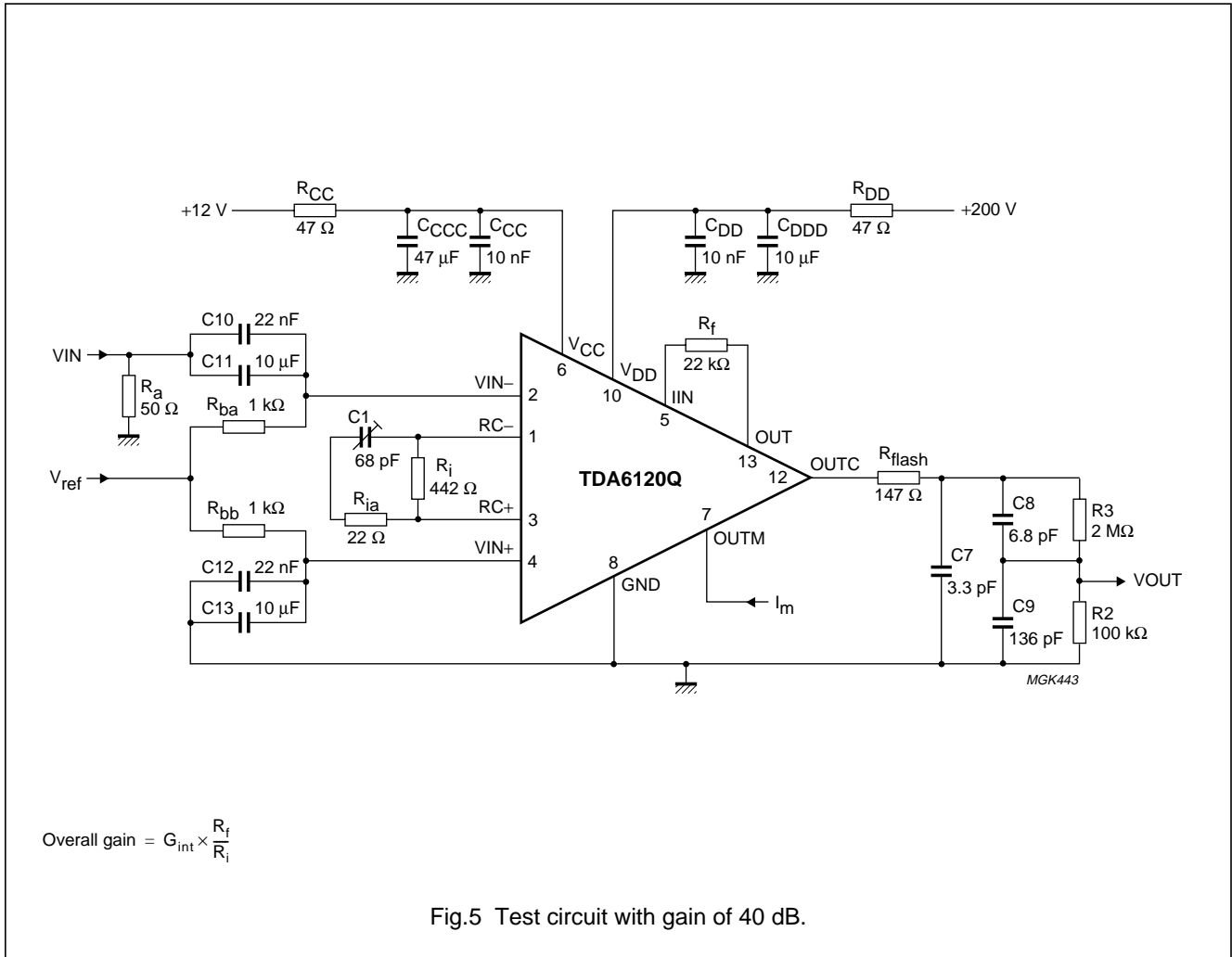

Video output amplifier

TDA6120Q

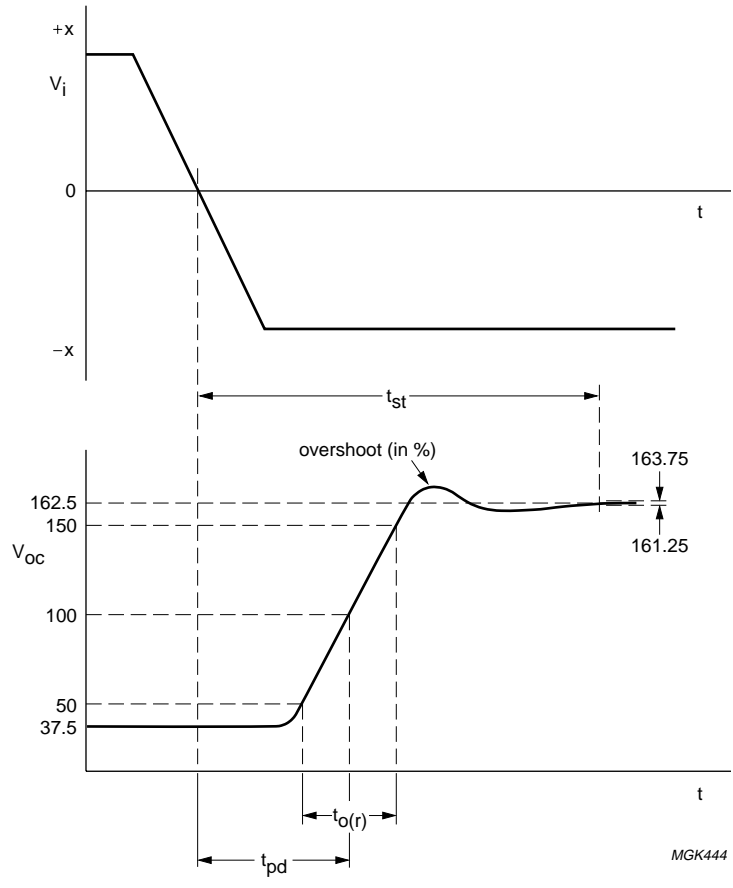

Fig.6 Output (pins 12 and 13; rising edge) as a function of input signal.

Video output amplifier

TDA6120Q

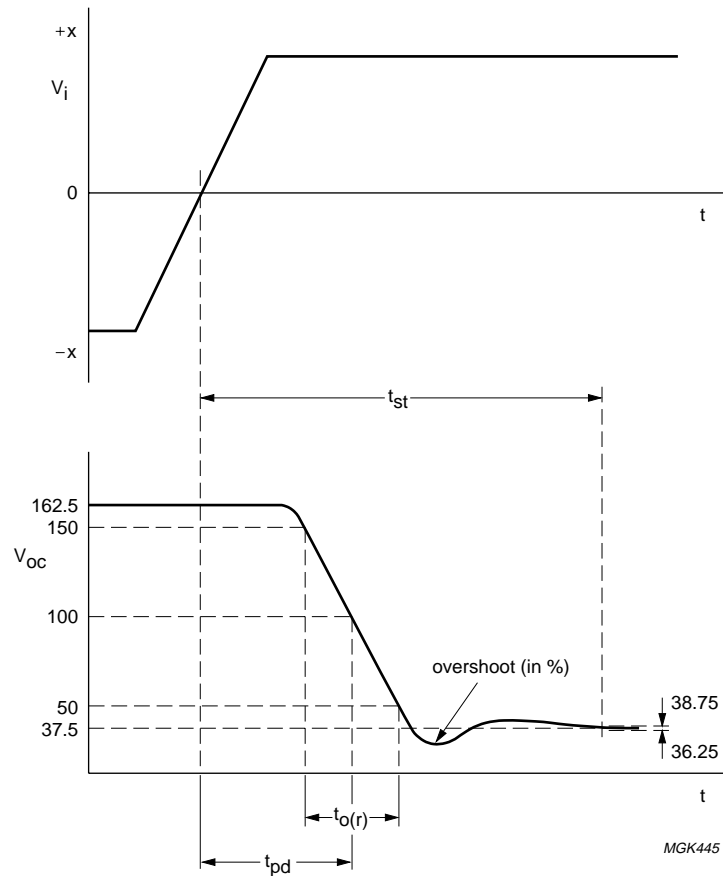

Fig.7 Output (pins 12 and 13; falling edge) as a function of input signal.

FLASHOVER PROTECTION

The TDA6120Q needs an external protection diode combined with a 50 Ω resistor to protect the video amplifier against CRT flashover discharge.

An external 147 Ω carbon high-voltage resistor in combination with a 2 kV spark gap between the cathode and ground will limit the maximum clamp current (for this resistor value, the CRT has to be connected to the main printed-circuit board).

This external network causes an increase in the rise and fall times and a decrease in the overshoot.

Pin 10 must be decoupled to pin 8:

- By a capacitor >100 nF with good HF behaviour (e.g. foil). This capacitor must be placed as close as possible to pins 10 and 8; definitely within 5 mm.
- By a capacitor >10 μ F on the picture tube base printed-circuit board (common for 3 output stages).

Video output amplifier

TDA6120Q

TEST AND APPLICATION INFORMATION

Dissipation

Regarding dissipation, distinction must be made between static dissipation (independent of frequency) and dynamic dissipation (proportional to frequency). The static dissipation of the TDA6120Q is due to supply currents, and currents in the feedback network and CRT.

The static dissipation is given by the following equation:

$$P_{stat} = V_{CC} \times I_{CC} + V_{DD} \times I_{DD} - V_{OUTC} \times \frac{V_{OUTC}}{R_f} - V_{OUTC} \times I_{OUTC}$$

Where:

R_f = feedback resistance

I_{OUTC} = DC cathode current.

The dynamic dissipation is given by the following equation:

$$P_{dyn} = V_{DD} \times (C_L + C_{int}) \times f \times V_{OUTC(p-p)} \times b$$

Where:

C_L = load capacitance

C_{int} = effective internal load capacitance (approximately 7 pF)

f = frequency

$V_{OUTC(p-p)}$ = output voltage (peak-to-peak value)

b = non-blanking duty cycle (0.8).

The IC must be mounted on the picture tube base printed-circuit board to minimize the load capacitance C_L .

Switch-off

The TDA6120Q is equipped with a switch-off circuit to guarantee a controlled switch-off behaviour of the output pins. The switch-off function is activated when the low supply voltage (V_{CC}) drops below a reference level ($V_{CC(sw)}$). Then the voltage at output pins OUT and OUTC is pulled to the high supply voltage level (V_{DD}), independant of input pin voltage levels.

Video output amplifier

TDA6120Q

INTERNAL PIN CONFIGURATION

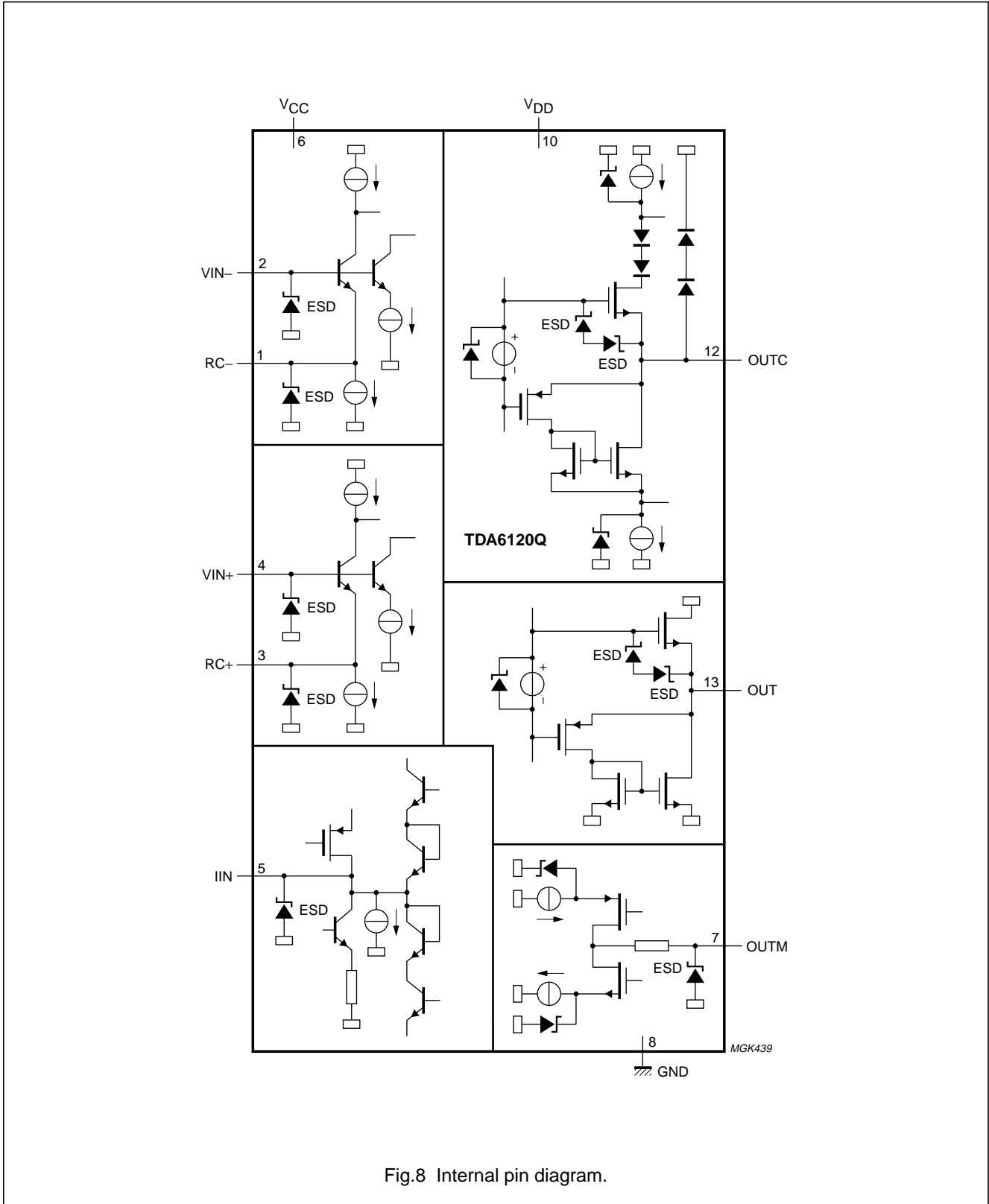

Fig.8 Internal pin diagram.

Video output amplifier

TDA6120Q

PACKAGE OUTLINE

DBS13P: plastic DIL-bent-SIL power package; 13 leads (lead length 7.7 mm)

SOT141-8

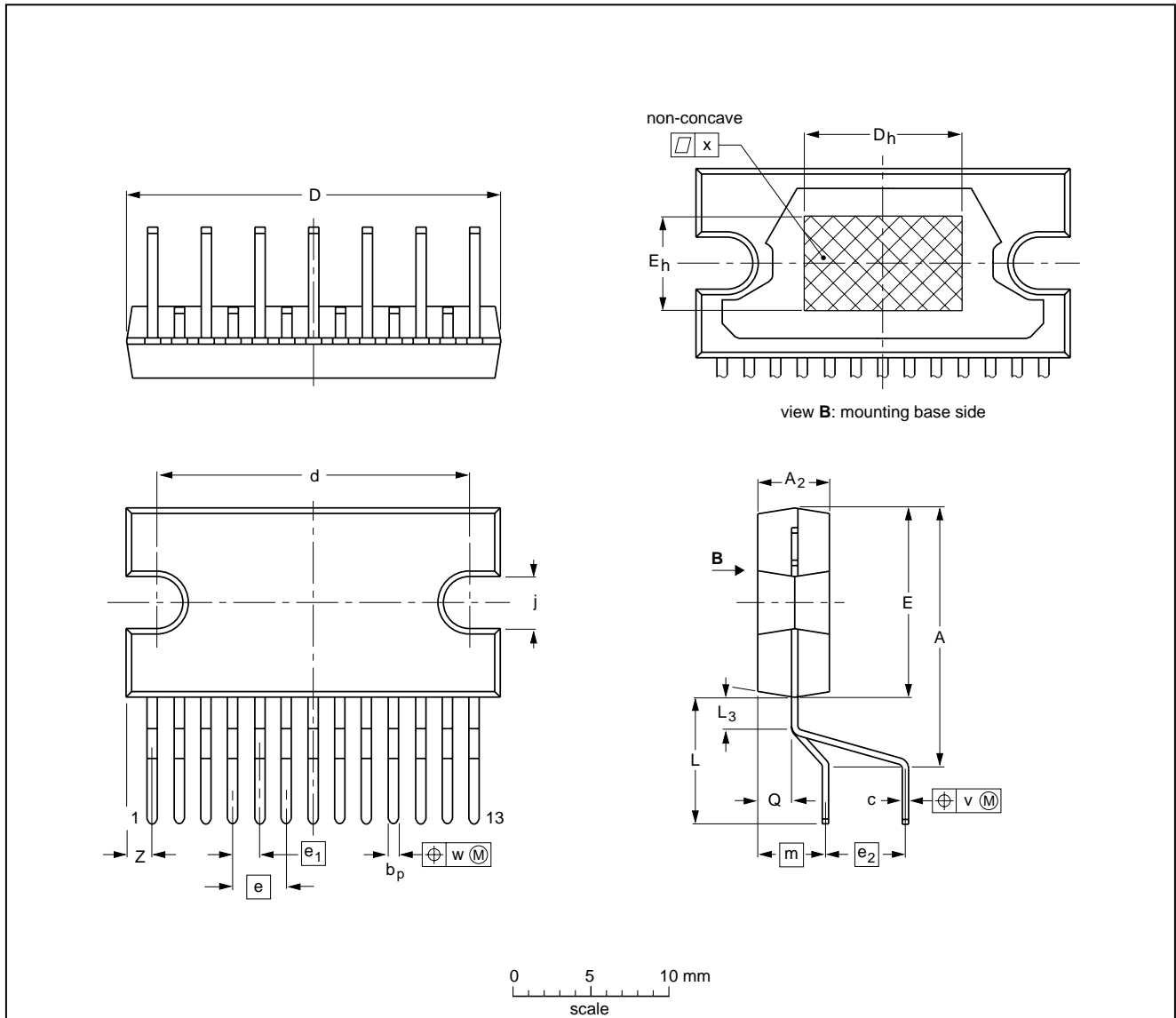

DIMENSIONS (mm are the original dimensions)

UNIT	A	A ₂	b _p	c	D ⁽¹⁾	d	D _h	E ⁽¹⁾	e	e ₁	e ₂	E _h	j	L	L ₃	m	Q	v	w	x	Z ⁽¹⁾
mm	17.0 15.5	4.6 4.4	0.75 0.60	0.48 0.38	24.0 23.6	20.0 19.6	10	12.2 11.8	3.4	1.7	5.08	6	3.4 3.1	8.4 7.0	2.4 1.6	4.3	2.1 1.8	0.6	0.25	0.03	2.00 1.45

Note

1. Plastic or metal protrusions of 0.25 mm maximum per side are not included.

OUTLINE VERSION	REFERENCES			EUROPEAN PROJECTION	ISSUE DATE
	IEC	JEDEC	EIAJ		
SOT141-8					97-12-16 99-12-17

Video output amplifier

TDA6120Q

SOLDERING

Introduction to soldering through-hole mount packages

This text gives a brief insight to wave, dip and manual soldering. A more in-depth account of soldering ICs can be found in our *“Data Handbook IC26; Integrated Circuit Packages”* (document order number 9398 652 90011).

Wave soldering is the preferred method for mounting of through-hole mount IC packages on a printed-circuit board.

Soldering by dipping or by solder wave

The maximum permissible temperature of the solder is 260 °C; solder at this temperature must not be in contact with the joints for more than 5 seconds.

The total contact time of successive solder waves must not exceed 5 seconds.

The device may be mounted up to the seating plane, but the temperature of the plastic body must not exceed the specified maximum storage temperature ($T_{stg(max)}$). If the printed-circuit board has been pre-heated, forced cooling may be necessary immediately after soldering to keep the temperature within the permissible limit.

Manual soldering

Apply the soldering iron (24 V or less) to the lead(s) of the package, either below the seating plane or not more than 2 mm above it. If the temperature of the soldering iron bit is less than 300 °C it may remain in contact for up to 10 seconds. If the bit temperature is between 300 and 400 °C, contact may be up to 5 seconds.

Suitability of through-hole mount IC packages for dipping and wave soldering methods

PACKAGE	SOLDERING METHOD	
	DIPPING	WAVE
DBS, DIP, HDIP, SDIP, SIL	suitable	suitable ⁽¹⁾

Note

1. For SDIP packages, the longitudinal axis must be parallel to the transport direction of the printed-circuit board.

Video output amplifier

TDA6120Q

DATA SHEET STATUS

DATA SHEET STATUS	PRODUCT STATUS	DEFINITIONS ⁽¹⁾
Objective specification	Development	This data sheet contains the design target or goal specifications for product development. Specification may change in any manner without notice.
Preliminary specification	Qualification	This data sheet contains preliminary data, and supplementary data will be published at a later date. Philips Semiconductors reserves the right to make changes at any time without notice in order to improve design and supply the best possible product.
Product specification	Production	This data sheet contains final specifications. Philips Semiconductors reserves the right to make changes at any time without notice in order to improve design and supply the best possible product.

Note

1. Please consult the most recently issued data sheet before initiating or completing a design.

DEFINITIONS

Short-form specification — The data in a short-form specification is extracted from a full data sheet with the same type number and title. For detailed information see the relevant data sheet or data handbook.

Limiting values definition — Limiting values given are in accordance with the Absolute Maximum Rating System (IEC 60134). Stress above one or more of the limiting values may cause permanent damage to the device. These are stress ratings only and operation of the device at these or at any other conditions above those given in the Characteristics sections of the specification is not implied. Exposure to limiting values for extended periods may affect device reliability.

Application information — Applications that are described herein for any of these products are for illustrative purposes only. Philips Semiconductors make no representation or warranty that such applications will be suitable for the specified use without further testing or modification.

DISCLAIMERS

Life support applications — These products are not designed for use in life support appliances, devices, or systems where malfunction of these products can reasonably be expected to result in personal injury. Philips Semiconductors customers using or selling these products for use in such applications do so at their own risk and agree to fully indemnify Philips Semiconductors for any damages resulting from such application.

Right to make changes — Philips Semiconductors reserves the right to make changes, without notice, in the products, including circuits, standard cells, and/or software, described or contained herein in order to improve design and/or performance. Philips Semiconductors assumes no responsibility or liability for the use of any of these products, conveys no licence or title under any patent, copyright, or mask work right to these products, and makes no representations or warranties that these products are free from patent, copyright, or mask work right infringement, unless otherwise specified.

Philips Semiconductors – a worldwide company

Argentina: see South America

Australia: 3 Figtree Drive, HOMEBUSH, NSW 2140,
 Tel. +61 2 9704 8141, Fax. +61 2 9704 8139

Austria: Computerstr. 6, A-1101 WIEN, P.O. Box 213,
 Tel. +43 1 60 101 1248, Fax. +43 1 60 101 1210

Belarus: Hotel Minsk Business Center, Bld. 3, r. 1211, Volodarski Str. 6,
 220050 MINSK, Tel. +375 172 20 0733, Fax. +375 172 20 0773

Belgium: see The Netherlands

Brazil: see South America

Bulgaria: Philips Bulgaria Ltd., Energoproject, 15th floor,
 51 James Bourchier Blvd., 1407 SOFIA,
 Tel. +359 2 68 9211, Fax. +359 2 68 9102

Canada: PHILIPS SEMICONDUCTORS/COMPONENTS,
 Tel. +1 800 234 7381, Fax. +1 800 943 0087

China/Hong Kong: 501 Hong Kong Industrial Technology Centre,
 72 Tat Chee Avenue, Kowloon Tong, HONG KONG,
 Tel. +852 2319 7888, Fax. +852 2319 7700

Colombia: see South America

Czech Republic: see Austria

Denmark: Sydhavnsgade 23, 1780 COPENHAGEN V,
 Tel. +45 33 29 3333, Fax. +45 33 29 3905

Finland: Sinikalliontie 3, FIN-02630 ESPOO,
 Tel. +358 9 615 800, Fax. +358 9 6158 0920

France: 51 Rue Carnot, BP317, 92156 SURESNES Cedex,
 Tel. +33 1 4099 6161, Fax. +33 1 4099 6427

Germany: Hammerbrookstraße 69, D-20097 HAMBURG,
 Tel. +49 40 2353 60, Fax. +49 40 2353 6300

Hungary: see Austria

India: Philips INDIA Ltd, Band Box Building, 2nd floor,
 254-D, Dr. Annie Besant Road, Worli, MUMBAI 400 025,
 Tel. +91 22 493 8541, Fax. +91 22 493 0966

Indonesia: PT Philips Development Corporation, Semiconductors Division,
 Gedung Philips, Jl. Buncit Raya Kav.99-100, JAKARTA 12510,
 Tel. +62 21 794 0040 ext. 2501, Fax. +62 21 794 0080

Ireland: Newstead, Clonskeagh, DUBLIN 14,
 Tel. +353 1 7640 000, Fax. +353 1 7640 200

Israel: RAPAC Electronics, 7 Kehilat Saloniki St, PO Box 18053,
 TEL AVIV 61180, Tel. +972 3 645 0444, Fax. +972 3 649 1007

Italy: PHILIPS SEMICONDUCTORS, Via Casati, 23 - 20052 MONZA (MI),
 Tel. +39 039 203 6838, Fax +39 039 203 6800

Japan: Philips Bldg 13-37, Kohnan 2-chome, Minato-ku,
 TOKYO 108-8507, Tel. +81 3 3740 5130, Fax. +81 3 3740 5057

Korea: Philips House, 260-199 Itaewon-dong, Yongsan-ku, SEOUL,
 Tel. +82 2 709 1412, Fax. +82 2 709 1415

Malaysia: No. 76 Jalan Universiti, 46200 PETALING JAYA, SELANGOR,
 Tel. +60 3 750 5214, Fax. +60 3 757 4880

Mexico: 5900 Gateway East, Suite 200, EL PASO, TEXAS 79905,
 Tel. +9-5 800 234 7381, Fax +9-5 800 943 0087

Middle East: see Italy

Netherlands: Postbus 90050, 5600 PB EINDHOVEN, Bldg. VB,
 Tel. +31 40 27 82785, Fax. +31 40 27 88399

New Zealand: 2 Wagener Place, C.P.O. Box 1041, AUCKLAND,
 Tel. +64 9 849 4160, Fax. +64 9 849 7811

Norway: Box 1, Manglerud 0612, OSLO,
 Tel. +47 22 74 8000, Fax. +47 22 74 8341

Pakistan: see Singapore

Philippines: Philips Semiconductors Philippines Inc.,
 106 Valero St. Salcedo Village, P.O. Box 2108 MCC, MAKATI,
 Metro MANILA, Tel. +63 2 816 6380, Fax. +63 2 817 3474

Poland: Al.Jerozolimskie 195 B, 02-222 WARSAW,
 Tel. +48 22 5710 000, Fax. +48 22 5710 001

Portugal: see Spain

Romania: see Italy

Russia: Philips Russia, Ul. Usatcheva 35A, 119048 MOSCOW,
 Tel. +7 095 755 6918, Fax. +7 095 755 6919

Singapore: Lorong 1, Toa Payoh, SINGAPORE 319762,
 Tel. +65 350 2538, Fax. +65 251 6500

Slovakia: see Austria

Slovenia: see Italy

South Africa: S.A. PHILIPS Pty Ltd., 195-215 Main Road Martindale,
 2092 JOHANNESBURG, P.O. Box 58088 Newville 2114,
 Tel. +27 11 471 5401, Fax. +27 11 471 5398

South America: Al. Vicente Pinzon, 173, 6th floor,
 04547-130 SÃO PAULO, SP, Brazil,
 Tel. +55 11 821 2333, Fax. +55 11 821 2382

Spain: Balmes 22, 08007 BARCELONA,
 Tel. +34 93 301 6312, Fax. +34 93 301 4107

Sweden: Kottbygatan 7, Akalla, S-16485 STOCKHOLM,
 Tel. +46 8 5985 2000, Fax. +46 8 5985 2745

Switzerland: Allmendstrasse 140, CH-8027 ZÜRICH,
 Tel. +41 1 488 2741 Fax. +41 1 488 3263

Taiwan: Philips Semiconductors, 5F, No. 96, Chien Kuo N. Rd., Sec. 1,
 TAIPEI, Taiwan Tel. +886 2 2134 2451, Fax. +886 2 2134 2874

Thailand: PHILIPS ELECTRONICS (THAILAND) Ltd.,
 60/14 MOO 11, Bangna Trad Road KM. 3, Bagna, BANGKOK 10260,
 Tel. +66 2 361 7910, Fax. +66 2 398 3447

Turkey: Yukari Dudullu, Org. San. Blg., 2.Cad. Nr. 28 81260 Umraniye,
 ISTANBUL, Tel. +90 216 522 1500, Fax. +90 216 522 1813

Ukraine: PHILIPS UKRAINE, 4 Patrice Lumumba str., Building B, Floor 7,
 252042 KIEV, Tel. +380 44 264 2776, Fax. +380 44 268 0461

United Kingdom: Philips Semiconductors Ltd., 276 Bath Road, Hayes,
 MIDDLESEX UB3 5BX, Tel. +44 208 730 5000, Fax. +44 208 754 8421

United States: 811 East Arques Avenue, SUNNYVALE, CA 94088-3409,
 Tel. +1 800 234 7381, Fax. +1 800 943 0087

Uruguay: see South America

Vietnam: see Singapore

Yugoslavia: PHILIPS, Trg N. Pasica 5/v, 11000 BEOGRAD,
 Tel. +381 11 3341 299, Fax.+381 11 3342 553

For all other countries apply to: Philips Semiconductors,
 Marketing Communications, Building BE-p, P.O. Box 218, 5600 MD EINDHOVEN,
 The Netherlands, Fax. +31 40 27 24825

Internet: <http://www.semiconductors.philips.com>

© Philips Electronics N.V. 2000

SCA 70

All rights are reserved. Reproduction in whole or in part is prohibited without the prior written consent of the copyright owner.

The information presented in this document does not form part of any quotation or contract, is believed to be accurate and reliable and may be changed without notice. No liability will be accepted by the publisher for any consequence of its use. Publication thereof does not convey nor imply any license under patent- or other industrial or intellectual property rights.

Printed in The Netherlands

753504/04/pp16

Date of release: 2000 Dec 13

Document order number: 9397 750 07562

Let's make things better.