



Distributor of Maxim Integrated: Excellent Integrated System Limited
Datasheet of MAX16800ATE+ - IC LED Driver Linear PWM Dimming 350mA Automotive,
Signage 16-TQFN (5x5)

Contact us: sales@integrated-circuit.com Website: www.integrated-circuit.com

Excellent Integrated System Limited

Stocking Distributor

Click to view price, real time Inventory, Delivery & Lifecycle Information:

[Maxim Integrated](#)
[MAX16800ATE+](#)

For any questions, you can email us directly:

sales@integrated-circuit.com



High-Voltage, 350mA, Adjustable Linear High-Brightness LED (HB LED) Driver

General Description

The MAX16800 current regulator operates from a 6.5V to 40V input voltage range and delivers up to a total of 350mA to one or more strings of high-brightness LEDs. The output current of the MAX16800 is adjusted by using an external current-sense resistor in series with the LEDs. An enable input allows wide-range "pulsed" dimming. Wave-shaping circuitry reduces EMI. The differential current-sense input increases noise immunity. The MAX16800 is well suited for applications requiring high-voltage input and is able to withstand automotive load-dump events up to 40V. An on-board pass element minimizes external components while providing $\pm 3.5\%$ output current accuracy. Additional features include a 5V regulated output and short-circuit and thermal protection.

The MAX16800 is available in a thermally enhanced, 5mm x 5mm, 16-pin TQFN package and is specified over the automotive -40°C to $+125^{\circ}\text{C}$ temperature range.

Applications

- Automotive Interior: Map, Courtesy, and Cluster Lighting
- Automotive Exterior: Tail Lights and CHMSL
- Warning Lights for Emergency Vehicles
- Navigation and Marine Indicators
- General Illumination
- Signage, Gasoline Canopies, Beacons

Pin Configuration

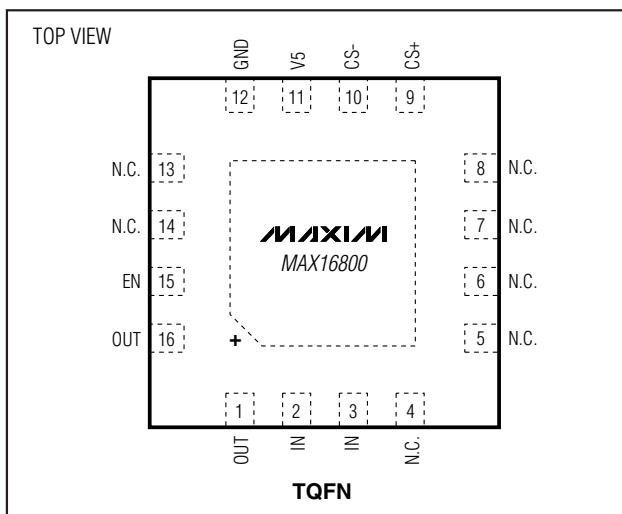

Features

- ◆ +6.5V to +40V Operating Range
- ◆ Adjustable Level (35mA to 350mA)
- ◆ $\pm 3.5\%$ Output Current Accuracy
- ◆ Integrated Pass Element with Low-Dropout Voltage (0.5V typ)
- ◆ Output Short-Circuit Protection
- ◆ +5V Regulated Output with 4mA Source Capability
- ◆ Thermal Shutdown
- ◆ Differential LED Current Sense
- ◆ High-Voltage Enable Pin for Dimming Interface
- ◆ Low Shutdown Supply Current (12 μA typ)
- ◆ Low 204mV Current-Sense Reference Reduces Power Losses
- ◆ Wave-Shaped Soft Edges Reduce Radiated EMI During PWM Dimming
- ◆ Available in Small, Thermally Enhanced, 5mm x 5mm, 16-Pin TQFN Package
- ◆ -40°C to $+125^{\circ}\text{C}$ Operating Temperature Range

Ordering Information

PART	TEMP RANGE	PIN-PACKAGE
MAX16800ATE+	-40°C to $+125^{\circ}\text{C}$	16 TQFN-EP*
MAX16800ATE/V+	-40°C to $+125^{\circ}\text{C}$	16 TQFN-EP*

+ Denotes a lead(Pb)-free/RoHS-compliant package.

*EP = Exposed paddle.

/V denotes an automotive qualified part.

Simplified Diagram

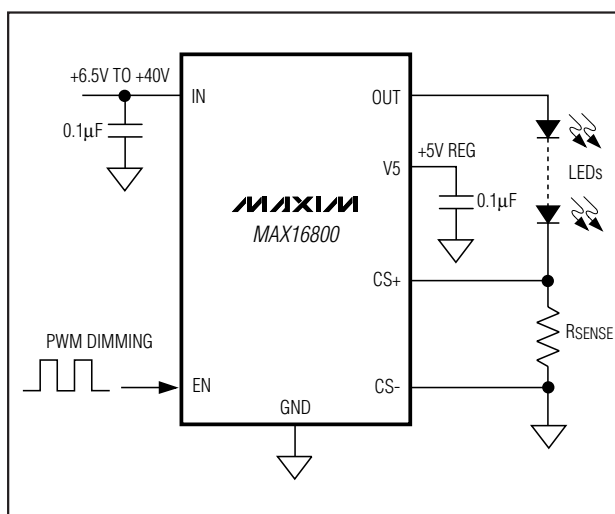

High-Voltage, 350mA, Adjustable Linear High-Brightness LED (HB LED) Driver

ABSOLUTE MAXIMUM RATINGS

IN, OUT, and EN to GND.....	-0.3V to +45V	Continuous Power Dissipation (T _A = +70°C) 16-Pin TQFN 5mm x 5mm (derate 33.3mW/°C above +70°C).....2666.7mW Operating Junction Temperature Range.....-40°C to +125°C Junction Temperature.....+150°C Storage Temperature Range.....-65°C to +150°C Lead Temperature (soldering, 10s).....+300°C
CS+, V5 to GND.....	-0.3V to +6V	
CS- to GND.....	-0.3V to +0.3V	
OUT Short Circuited to GND Duration (at V _{IN} = +16V).....	60 minutes	
Maximum Current Into Any Pin (except V _{IN} and OUT).....	±20mA	

Stresses beyond those listed under "Absolute Maximum Ratings" may cause permanent damage to the device. These are stress ratings only, and functional operation of the device at these or any other conditions beyond those indicated in the operational sections of the specifications is not implied. Exposure to absolute maximum rating conditions for extended periods may affect device reliability.

ELECTRICAL CHARACTERISTICS

(V_{IN} = +12V, EN = V_{IN}, C_{V5} = 0.1µF to GND, I_{V5} = 0, CS- = GND, connect R_{SENSE} = 0.58Ω between CS+ and CS-. Connect OUT to CS+ (Note 1). T_J = -40°C to +125°C, unless otherwise noted. Typical values are at T_A = +25°C.) (Note 2)

PARAMETER	SYMBOL	CONDITIONS	MIN	TYP	MAX	UNITS
Supply Voltage Range	V _{IN}	(Note 1)	6.5		40.0	V
Ground Current	I _G	I _{LOAD} = 350mA		1.4	3	mA
Shutdown Supply Current	I _{SHDN}	V _{EN} ≤ 0.6V		12	40	µA
Guaranteed Output Current	I _{OUT}	R _{SENSE} = 0.55Ω	350			mA
Output Current Accuracy		35mA < I _{OUT} < 350mA		±3.5		%
Dropout Voltage (Note 3)	ΔV _{D0}	I _{OUT} = 350mA (current pulsed), 12V < V _{IN} < 40V		0.5	1.2	V
		I _{OUT} = 350mA (current pulsed), 6.5V < V _{IN} < 40V		0.5	1.5	V
Output Current Slew Rate		Current rising		5.4		mA/µs
		Current falling		90		
Short-Circuit Current		V _{OUT} = 0V, V _{IN} = 12V	400	600	800	mA
LOGIC INPUT						
EN Input Current	I _{EN}				100	nA
EN Input Voltage High	V _{IH}				2.8	V
EN Input Voltage Low	V _{IL}		0.6			V
Turn-On Time	t _{ON}	EN rising edge to 90% of OUT		135	350	µs
CURRENT SENSE (Note 4)						
Regulated R _{SENSE} Voltage	V _{RSNS}	V _{SENSE} = V _{CS+} - V _{CS-}	197	204	211	mV
Input Current (CS+)		V _{CS+} = 220mV	-14			µA
Input Current (CS-)		V _{CS+} = 220mV			+84	µA

High-Voltage, 350mA, Adjustable Linear High-Brightness LED (HB LED) Driver

ELECTRICAL CHARACTERISTICS (continued)

($V_{IN} = +12V$, $EN = V_{IN}$, $C_{V5} = 0.1\mu F$ to GND, $I_{V5} = 0$, $CS^- = GND$, connect $R_{SENSE} = 0.58\Omega$ between CS^+ and CS^- . Connect OUT to CS^+ (Note 1). $T_J = -40^\circ C$ to $+125^\circ C$, unless otherwise noted. Typical values are at $T_A = +25^\circ C$.) (Note 2)

PARAMETER	SYMBOL	CONDITIONS	MIN	TYP	MAX	UNITS
THERMAL OVERLOAD						
Thermal-Shutdown Temperature				+155		$^\circ C$
Thermal-Shutdown Hysteresis				23		$^\circ C$
+5V REGULATOR						
Output Voltage Regulation	V5		5.0	5.27	5.5	V
Output Voltage Change	$\Delta V5$	$0 < I_{LOAD} < 4mA$ (Note 5)		15	60	Ω
V5 Short-Circuit Current		$V5 = 0V$ (Note 6)		30		mA

Note 1: Resistors were added from OUT to CS^+ to aid with the power dissipation during testing.

Note 2: All devices 100% production tested at $T_A = +25^\circ C$. Limits over the operating temperature range are guaranteed by design.

Note 3: Dropout is measured as follows:

Connect $R_O = 27\Omega$ from OUT to CS^+ . Connect $R_{SENSE} = 0.58\Omega$ from CS^+ to CS^- . Set $V_{IN} = +12V$ (record V_{OUT} as V_{OUT1}). Reduce V_{IN} until $V_{OUT} = 0.97 \times V_{OUT1}$ (record as V_{IN2} and V_{OUT2}). $\Delta V_{DO} = V_{IN2} - V_{OUT2}$.

Note 4: $I_{V5} = 0mA$.

Note 5: Current regulation varies with V5 load (see the *Typical Operating Characteristics*).

Note 6: Thermal shutdown does not function if the output of the 5V reference is shorted to ground.

Typical Operating Characteristics

($V_{IN} = V_{EN} = +12V$, $T_A = +25^\circ C$, unless otherwise noted.)

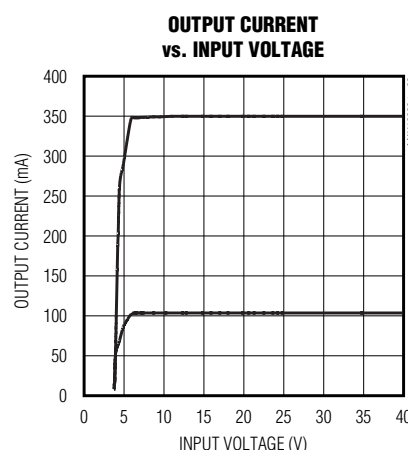
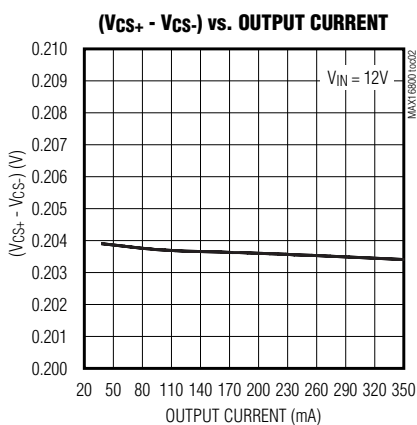
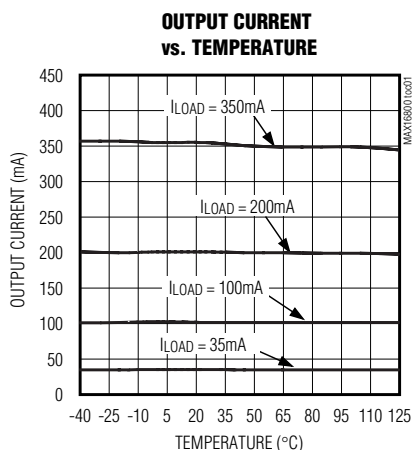

High-Voltage, 350mA, Adjustable Linear High-Brightness LED (HB LED) Driver

Typical Operating Characteristics (continued)

($V_{IN} = V_{EN} = +12V$, $T_A = +25^\circ C$, unless otherwise noted.)

DROPOUT VOLTAGE vs. TEMPERATURE

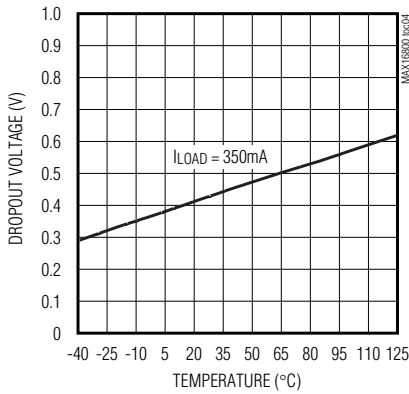

SHUTDOWN CURRENT vs. TEMPERATURE

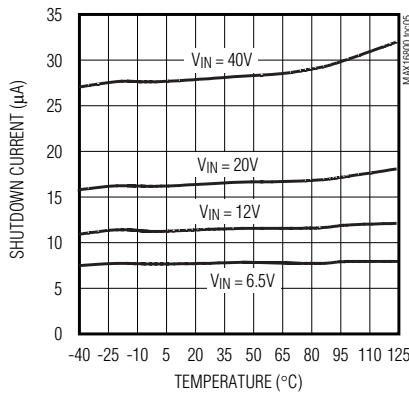

+5V REGULATOR OUTPUT vs. TEMPERATURE

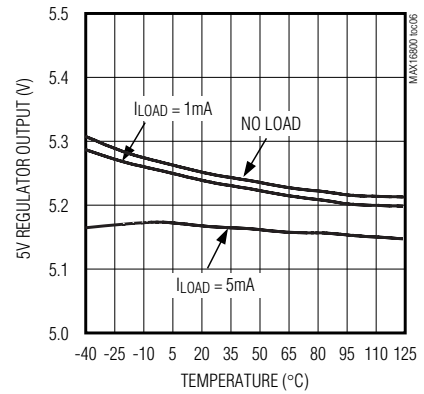

(Vcs+ - Vcs-) vs. I_{v5}

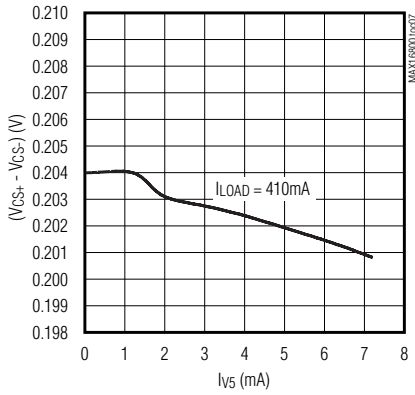

+5V REGULATOR OUTPUT vs. V_{IN}

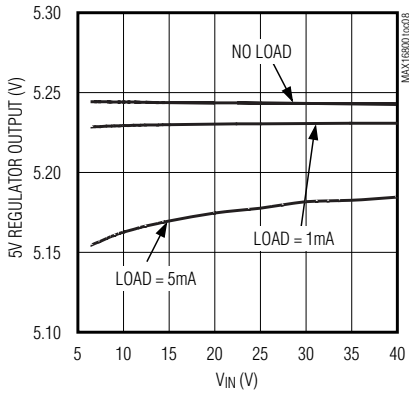

200Hz DIMMED OPERATION

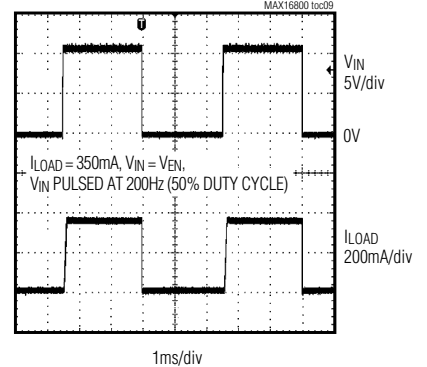

200Hz DIMMED OPERATION EXPANDED

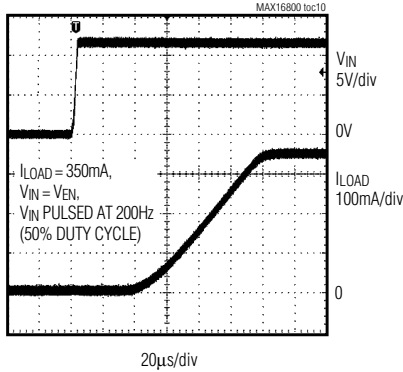

200Hz DIMMED OPERATION EXPANDED

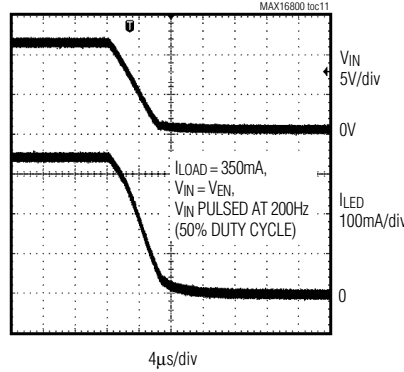

200Hz DIMMED OPERATION

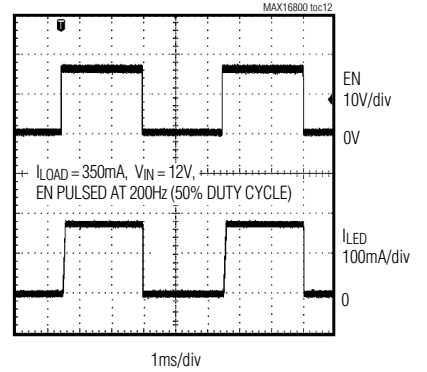

High-Voltage, 350mA, Adjustable Linear High-Brightness LED (HB LED) Driver

Pin Description

PIN	NAME	FUNCTION
1, 16	OUT	Current-Regulated Output. Connect pin 1 to pin 16.
2, 3	IN	Positive Input Supply. Bypass IN with a 0.1 μ F (min) capacitor to GND. Connect pin 2 to pin 3.
4–8, 13, 14	N.C.	Not Internally Connected
9	CS+	Positive Input of the Internal Differential Amplifier. Connect the current-sense resistor between CS+ and CS- to program the output current level.
10	CS-	Negative Input of the Internal Differential Amplifier. Connect the current-sense resistor between CS- and CS+ to program the output current level.
11	V5	+5V Regulated Output. Connect a 0.1 μ F capacitor from V5 to GND.
12	GND	Ground
15	EN	Enable Input. Drive EN high to enable the output.
—	EP	Exposed Pad. Connect to the ground plane for effective power dissipation. Do not use as the only ground connection.

MAX16800

Functional Diagram

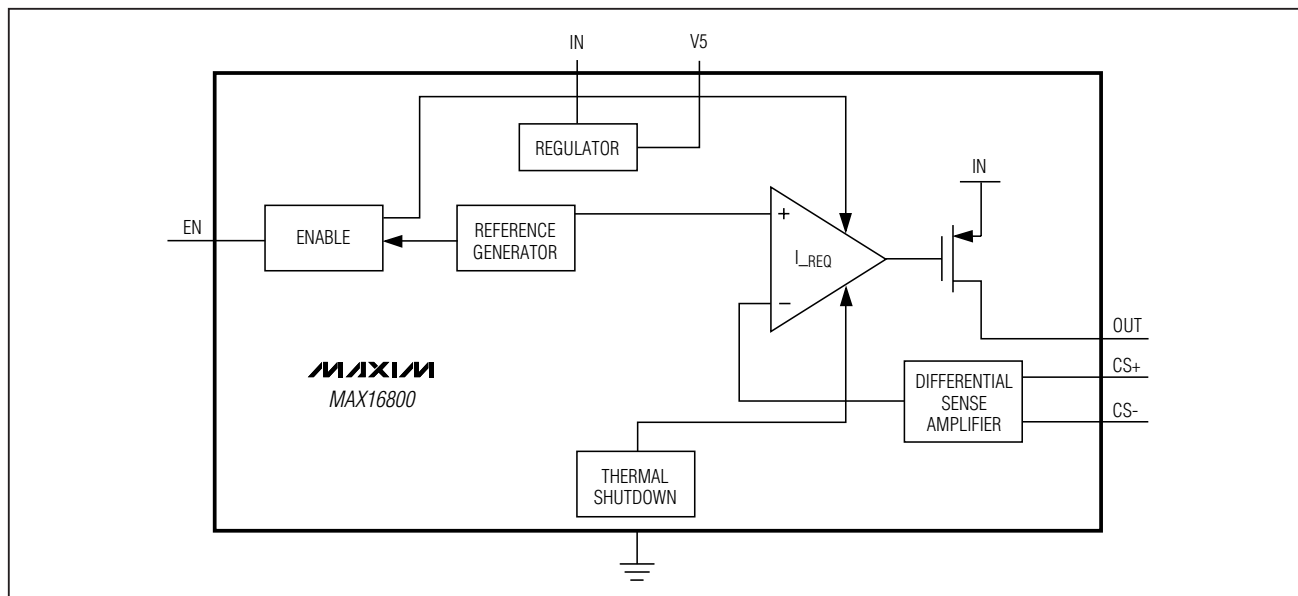

Detailed Description

The MAX16800 is a high-current regulator capable of providing up to a total of 350mA of current to one or more strings of high-brightness LEDs. A wide operating input voltage range of +6.5V to +40V makes the MAX16800 ideal for automotive applications. A +5V regulated output provides up to 4mA of current to power external circuitry. In addition, the MAX16800 fea-

tures thermal and output short-circuit protection. The wide operating voltage range helps protect the MAX16800 against large transients such as those found in load-dump situations up to 40V.

The MAX16800 uses a feedback loop to control the output current. The differential voltage across the sense resistor is compared to a fixed reference voltage, and the error is amplified to serve as the drive to the internal

High-Voltage, 350mA, Adjustable Linear High-Brightness LED (HB LED) Driver

power series pass device (see the *Functional Diagram*). The regulation point is factory set at $(V_{CS+} - V_{CS-}) = 204mV \pm 3.5\%$. The regulated current is user defined by the value of R_{SENSE} .

The MAX16800 is a current controller internally optimized for driving the impedance range expected from one or more HB LEDs.

+5V Regulator

The MAX16800 includes a fixed +5V output regulator that delivers up to 4mA of load current for low-power applications throughout the +6.5V to +40V input voltage range. Connect a 0.1µF compensation capacitor from V5 to ground. Shorting V5 to ground disables the thermal shutdown.

Thermal Protection

The MAX16800 enters a thermal-shutdown mode in the event of overheating. This typically occurs in overload or output short-circuit conditions. When the junction temperature exceeds $T_J = +155^\circ C$ (typ), the internal thermal-protection circuitry turns off the series pass device. The MAX16800 recovers from thermal-shutdown mode once the junction temperature drops by 23°C (typ). The part will therefore protect itself by thermally cycling in the event of a short-circuit or overload condition.

Applications Information

Programming the LED Current

The MAX16800 uses a sense resistor across $CS+$ and $CS-$ to set the LED current. The differential sense ampli-

fier connected across R_{SENSE} provides ground-loop immunity and low-frequency noise rejection. The LED current is given by the equation below:

$$I_{LED} = V_{SENSE} / R_{SENSE}$$

Input Voltage Considerations

For proper operation, the minimum input voltage must always be +1.2V (+1.5V for $V_{IN} < +12V$) higher than the worst-case sum of all the forward drops of all series-connected LEDs to the output of the MAX16800. The minimum operating voltage of the device is +6.5V. The device will operate below +6.5V; however, output current may not meet the full regulation specification (see the *Typical Operating Characteristics*).

Low-Frequency PWM at the Output

The MAX16800 provides pulsed or chopped current dimming. Generally, high-brightness LEDs are binned to match at their full-rated current; however, LEDs from the same bin exhibit poor matching at currents other than full-rated current. To achieve uniformity, HB LED manufacturers recommend PWM pulsing of the LED current at their full-rated value. There are two methods for producing a PWM output. One method is by pulsing the enable input (EN) while having a constant voltage at IN. The other method is to connect EN to IN and pulse both EN and IN. Both methods generate a regulated-amplitude PWM current (variable duty cycle) that can provide control over the LED brightness (see Figures 1 and 2).

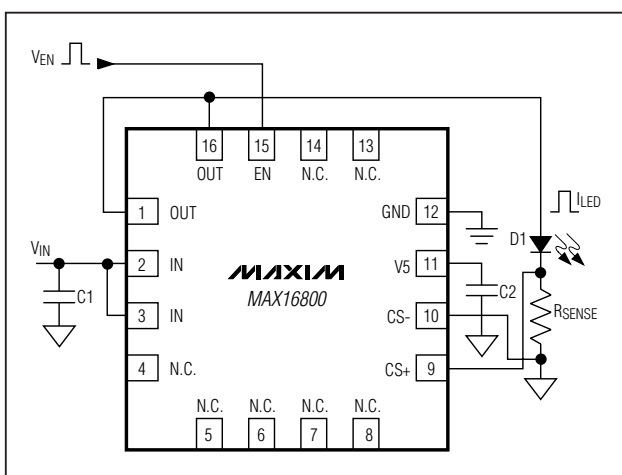

Figure 1. Pulse Application with V_{IN} at a Constant Voltage

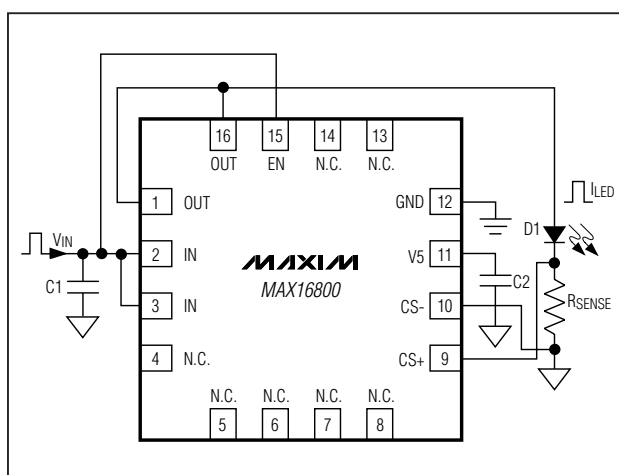
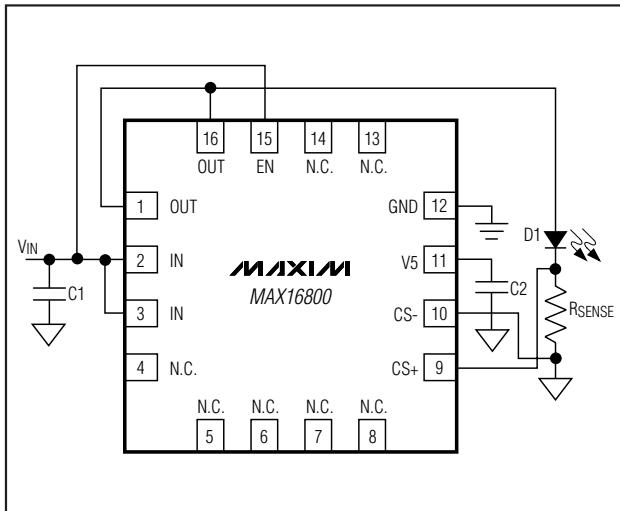

Figure 2. Pulse Application with EN Connected to V_{IN}

High-Voltage, 350mA, Adjustable Linear High-Brightness LED (HB LED) Driver

Typical Operating Circuit



Chip Information

PROCESS: BiCMOS

Package Information

For the latest package outline information and land patterns, go to www.maxim-ic.com/packages.

PACKAGE TYPE	PACKAGE CODE	DOCUMENT NO.
16 TQFN-EP	T1655-3	21-0140

MAX16800

High-Voltage, 350mA, Adjustable Linear High-Brightness LED (HB LED) Driver

Revision History

REVISION NUMBER	REVISION DATE	DESCRIPTION	PAGES CHANGED
0	8/05	Initial release	—
1	4/09	Updated data sheet with automotive part.	1, 8

MAX16800

Maxim cannot assume responsibility for use of any circuitry other than circuitry entirely embodied in a Maxim product. No circuit patent licenses are implied. Maxim reserves the right to change the circuitry and specifications without notice at any time.

8 **Maxim Integrated Products, 120 San Gabriel Drive, Sunnyvale, CA 94086 408-737-7600**