

## Excellent Integrated System Limited

Stocking Distributor

Click to view price, real time Inventory, Delivery & Lifecycle Information:

[Cypress Semiconductor](#)  
[CY7C1018CV33-12VXI](#)

For any questions, you can email us directly:

[sales@integrated-circuit.com](mailto:sales@integrated-circuit.com)



**CY7C1018CV33**

**128K x 8 Static RAM**

**Features**

- Pin- and function-compatible with CY7C1018BV33
- High speed
  - $t_{AA} = 10 \text{ ns}$
- CMOS for optimum speed/power
- Center power/ground pinout
- Data retention at 2.0V
- Automatic power-down when deselected
- Easy memory expansion with CE and OE options
- Available in Pb-free and non Pb-free 300-mil-wide 32-pin SOJ

**Functional Description<sup>[1]</sup>**

The CY7C1018CV33 is a high-performance CMOS static RAM organized as 131,072 words by 8 bits. Easy memory expansion is provided by an active LOW Chip Enable (CE), an active LOW Output Enable (OE), and tri-state drivers. This

device has an automatic power-down feature that significantly reduces power consumption when deselected.

Writing to the device is accomplished by taking Chip Enable (CE) and Write Enable (WE) inputs LOW. Data on the eight I/O pins (I/O<sub>0</sub> through I/O<sub>7</sub>) is then written into the location specified on the address pins (A<sub>0</sub> through A<sub>16</sub>).

Reading from the device is accomplished by taking Chip Enable (CE) and Output Enable (OE) LOW while forcing Write Enable (WE) HIGH. Under these conditions, the contents of the memory location specified by the address pins will appear on the I/O pins.

The eight input/output pins (I/O<sub>0</sub> through I/O<sub>7</sub>) are placed in a high-impedance state when the device is deselected (CE HIGH), the outputs are disabled (OE HIGH), or during a write operation (CE LOW, and WE LOW).

The CY7C1018CV33 is available in a standard 300-mil-wide SOJ.

**Logic Block Diagram**

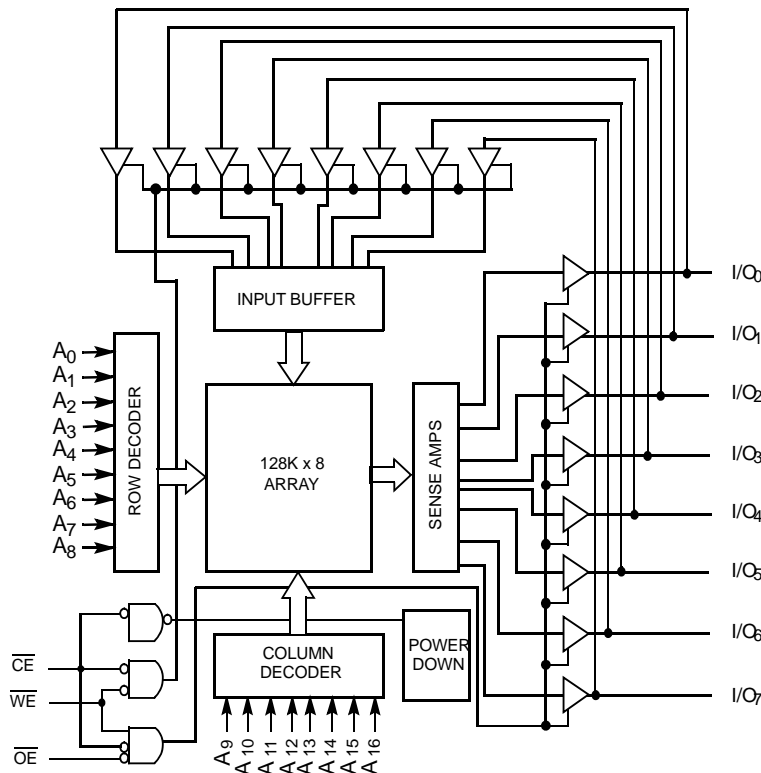

**Pin Configurations**

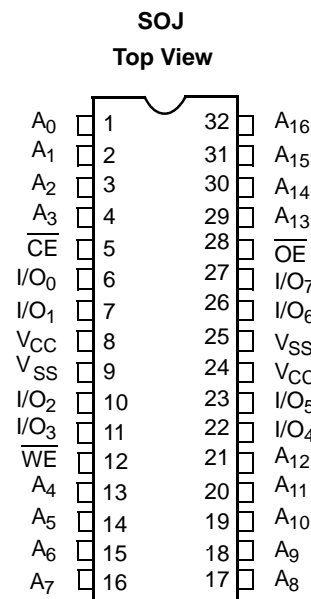

**Note:**

1. For guidelines on SRAM system designs, please refer to the 'System Design Guidelines' Cypress application note, available on the internet at www.cypress.com.



## CY7C1018CV33

### Selection Guide

		-10	-12	-15	Unit
Maximum Access Time		10	12	15	ns
Maximum Operating Current	Comm'l	90	85	80	mA
	Ind'l		85		mA
Maximum Standby Current		5	5	5	mA

### Maximum Ratings

(Above which the useful life may be impaired. For user guidelines, not tested.)

Storage Temperature ..... -65°C to +150°C

Ambient Temperature with Power Applied..... -55°C to +125°C

Supply Voltage on  $V_{CC}$  Relative to GND<sup>[2]</sup> ... -0.5V to +4.6V

DC Voltage Applied to Outputs<sup>[6]</sup> in High-Z State ..... -0.5V to  $V_{CC} + 0.5V$

DC Input Voltage<sup>[2]</sup>..... -0.5V to  $V_{CC} + 0.5V$

Current into Outputs (LOW)..... 20 mA

Static Discharge Voltage..... > 2001V (per MIL-STD-883, Method 3015)

Latch-up Current..... > 200 mA

### Operating Range

Range	Ambient Temperature	$V_{CC}$
Commercial	0°C to +70°C	3.3V ± 10%
Industrial	-40°C to +85°C	3.3V ± 10%

### Electrical Characteristics Over the Operating Range

Parameter	Description	Test Conditions	-10		-12		-15		Unit
			Min.	Max.	Min.	Max.	Min.	Max.	
$V_{OH}$	Output HIGH Voltage	$V_{CC} = \text{Min.}, I_{OH} = -4.0 \text{ mA}$	2.4		2.4		2.4		V
$V_{OL}$	Output LOW Voltage	$V_{CC} = \text{Min.}, I_{OL} = 8.0 \text{ mA}$		0.4		0.4		0.4	V
$V_{IH}$	Input HIGH Voltage		2.0	$V_{CC} + 0.3$	2.0	$V_{CC} + 0.3$	2.0	$V_{CC} + 0.3$	V
$V_{IL}$	Input LOW Voltage <sup>[2]</sup>		-0.3	0.8	-0.3	0.8	-0.3	0.8	V
$I_{IX}$	Input Leakage Current	$GND \leq V_I \leq V_{CC}$	-1	+1	-1	+1	-1	+1	μA
$I_{OZ}$	Output Leakage Current	$GND \leq V_I \leq V_{CC},$ Output Disabled	-1	+1	-1	+1	-1	+1	μA
$I_{CC}$	$V_{CC}$ Operating Supply Current	$V_{CC} = \text{Max.}, I_{OUT} = 0 \text{ mA}, f = f_{MAX} = 1/t_{RC}$	Comm'l	90		85		80	mA
			Ind'l			85			mA
$I_{SB1}$	Automatic CE Power-down Current —TTL Inputs	Max. $V_{CC}, \overline{CE} \geq V_{IH}$ $V_{IN} \geq V_{IH}$ or $V_{IN} \leq V_{IL}, f = f_{MAX}$	Comm'l	15		15		15	mA
			Ind'l			15			mA
$I_{SB2}$	Automatic CE Power-down Current —CMOS Inputs	Max. $V_{CC},$ $\overline{CE} \geq V_{CC} - 0.3V,$ $V_{IN} \geq V_{CC} - 0.3V,$ or $V_{IN} \leq 0.3V, f = 0$	Comm'l	5		5		5	mA
			Ind'l			5			mA

### Capacitance<sup>[3]</sup>

Parameter	Description	Test Conditions	Max.	Unit
$C_{IN}$	Input Capacitance	$T_A = 25^\circ\text{C}, f = 1 \text{ MHz}, V_{CC} = 3.3V$	8	pF
$C_{OUT}$	Output Capacitance		8	pF

#### Notes:

- $V_{IL}(\text{min.}) = -2.0V$  for pulse durations of less than 20 ns.
- Tested initially and after any design or process changes that may affect these parameters.



## CY7C1018CV33

### AC Test Loads and Waveforms<sup>[4]</sup>

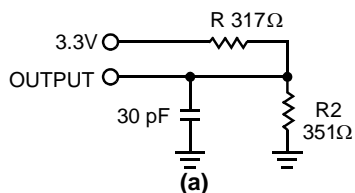

High-Z characteristics:

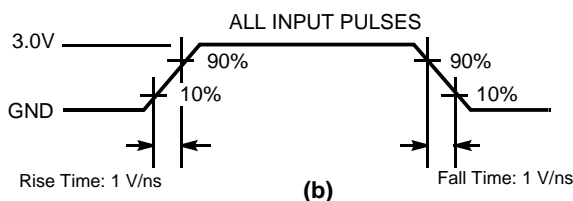
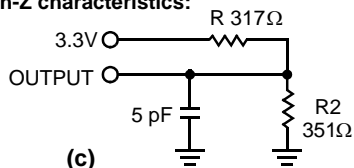

### Switching Characteristics Over the Operating Range<sup>[5]</sup>

Parameter	Description	-10		-12		-15		Unit
		Min.	Max.	Min.	Max.	Min.	Max.	
<b>Read Cycle</b>								
$t_{RC}$	Read Cycle Time	10		12		15		ns
$t_{AA}$	Address to Data Valid		10		12		15	ns
$t_{OHA}$	Data Hold from Address Change	3		3		3		ns
$t_{ACE}$	$\overline{CE}$ LOW to Data Valid		10		12		15	ns
$t_{DOE}$	$\overline{OE}$ LOW to Data Valid		5		6		7	ns
$t_{LZOE}$	$\overline{OE}$ LOW to Low-Z	0		0		0		ns
$t_{HZOE}$	$\overline{OE}$ HIGH to High-Z <sup>[6, 7]</sup>		5		6		7	ns
$t_{LZCE}$	$\overline{CE}$ LOW to Low-Z <sup>[7]</sup>	3		3		3		ns
$t_{HZCE}$	$\overline{CE}$ HIGH to High-Z <sup>[6, 7]</sup>		5		6		7	ns
$t_{PU}^{[8]}$	$\overline{CE}$ LOW to Power-up	0		0		0		ns
$t_{PD}^{[8]}$	$\overline{CE}$ HIGH to Power-down		10		12		15	ns
<b>Write Cycle<sup>[9, 10]</sup></b>								
$t_{WC}$	Write Cycle Time	10		12		15		ns
$t_{SCE}$	$\overline{CE}$ LOW to Write End	8		9		10		ns
$t_{AW}$	Address Set-up to Write End	8		9		10		ns
$t_{HA}$	Address Hold from Write End	0		0		0		ns
$t_{SA}$	Address Set-up to Write Start	0		0		0		ns
$t_{PWE}$	$\overline{WE}$ Pulse Width	7		8		10		ns
$t_{SD}$	Data Set-up to Write End	5		6		8		ns
$t_{HD}$	Data Hold from Write End	0		0		0		ns
$t_{LZWE}$	$\overline{WE}$ HIGH to Low-Z <sup>[7]</sup>	3		3		3		ns
$t_{HZWE}$	$\overline{WE}$ LOW to High-Z <sup>[6, 7]</sup>		5		6		7	ns

#### Notes:

- AC characteristics (except High-Z) for all speeds are tested using the Thévenin load shown in Figure (a). High-Z characteristics are tested for all speeds using the test load shown in Figure (c).
- Test conditions assume signal transition time of 3 ns or less, timing reference levels of 1.5V, input pulse levels of 0 to 3.0V.
- $t_{HZOE}$ ,  $t_{HZCE}$ , and  $t_{HZWE}$  are specified with a load capacitance of 5 pF as in (d) of AC Test Loads. Transition is measured  $\pm 500$  mV from steady-state voltage.
- At any given temperature and voltage condition,  $t_{HZCE}$  is less than  $t_{LZCE}$ ,  $t_{HZOE}$  is less than  $t_{LZOE}$ , and  $t_{HZWE}$  is less than  $t_{LZWE}$  for any given device.
- This parameter is guaranteed by design and is not tested.
- The internal Write time of the memory is defined by the overlap of  $\overline{CE}$  LOW and  $\overline{WE}$  LOW.  $\overline{CE}$  and  $\overline{WE}$  must be LOW to initiate a Write, and the transition of any of these signals can terminate the Write. The input data set-up and hold timing should be referenced to the leading edge of the signal that terminates the Write.
- The minimum Write cycle time for Write Cycle No. 3 (WE controlled, OE LOW) is the sum of  $t_{HZWE}$  and  $t_{SD}$ .



**CY7C1018CV33**

**Switching Waveforms**

**Read Cycle No. 1**<sup>[11, 12]</sup>

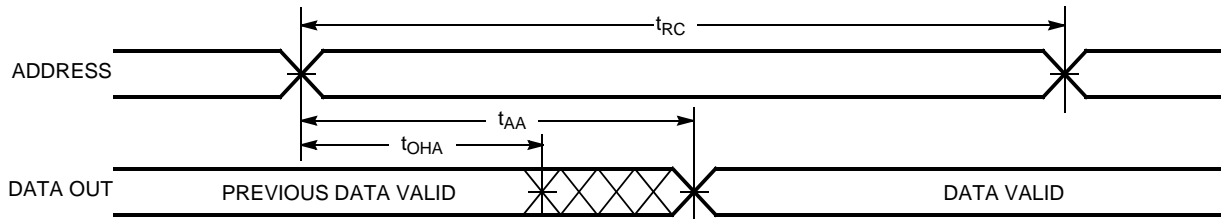

**Read Cycle No. 2 ( $\overline{OE}$  Controlled)**<sup>[12, 13]</sup>

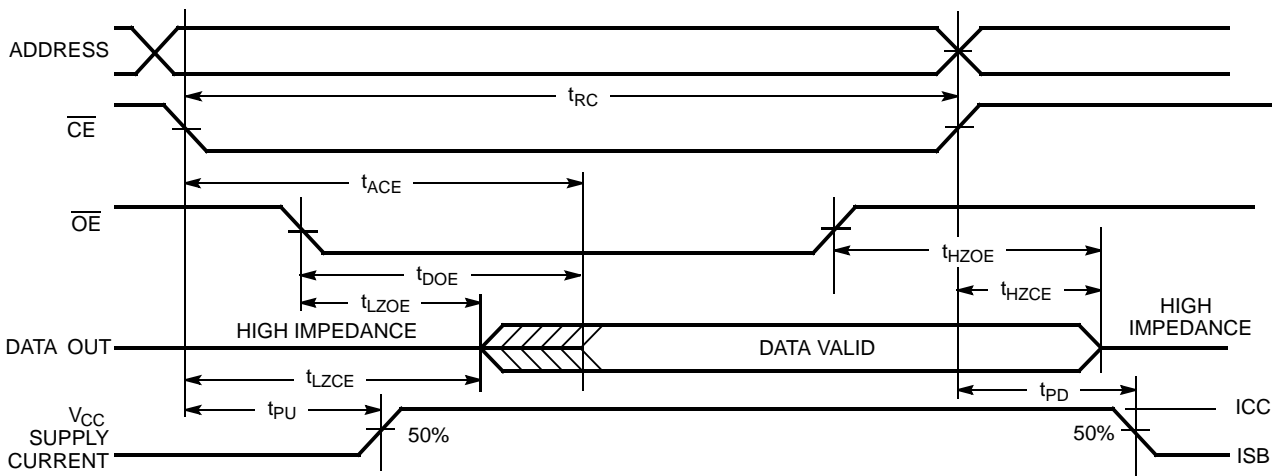

**Write Cycle No. 1 ( $\overline{CE}$  Controlled)**<sup>[14, 15]</sup>

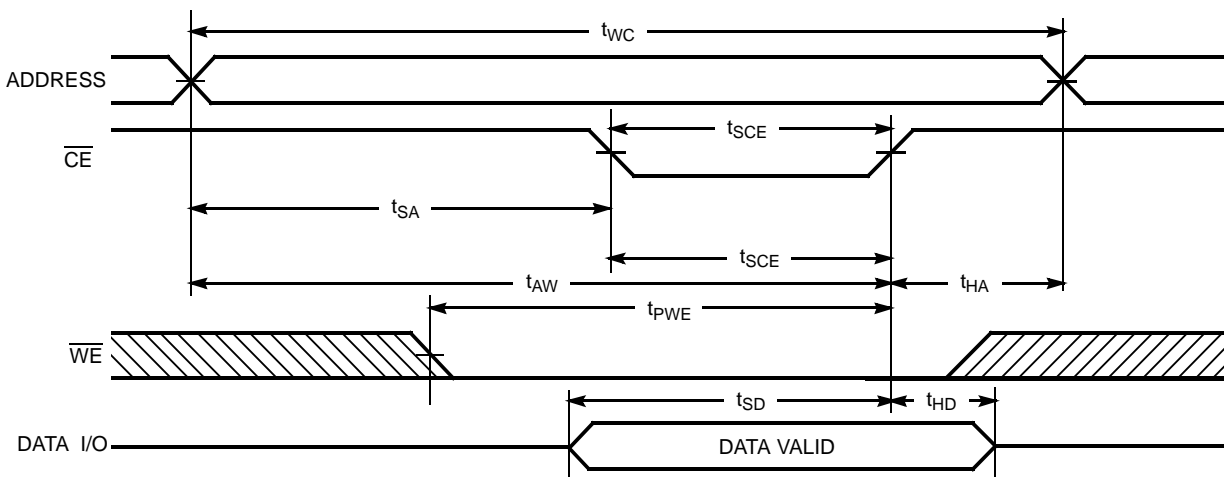

**Notes:**

11. Device is continuously selected.  $\overline{OE}, \overline{CE} = V_{IL}$ .
12.  $\overline{WE}$  is HIGH for Read cycle.
13. Address valid prior to or coincident with  $\overline{CE}$  transition LOW.
14. Data I/O is high impedance if  $\overline{OE} = V_{IH}$ .
15. If  $\overline{CE}$  goes HIGH simultaneously with  $\overline{WE}$  going HIGH, the output remains in a high-impedance state.



**CY7C1018CV33**

**Switching Waveforms** (continued)

**Write Cycle No. 2 ( $\overline{WE}$  Controlled,  $\overline{OE}$  HIGH During Write)<sup>[14, 15]</sup>**

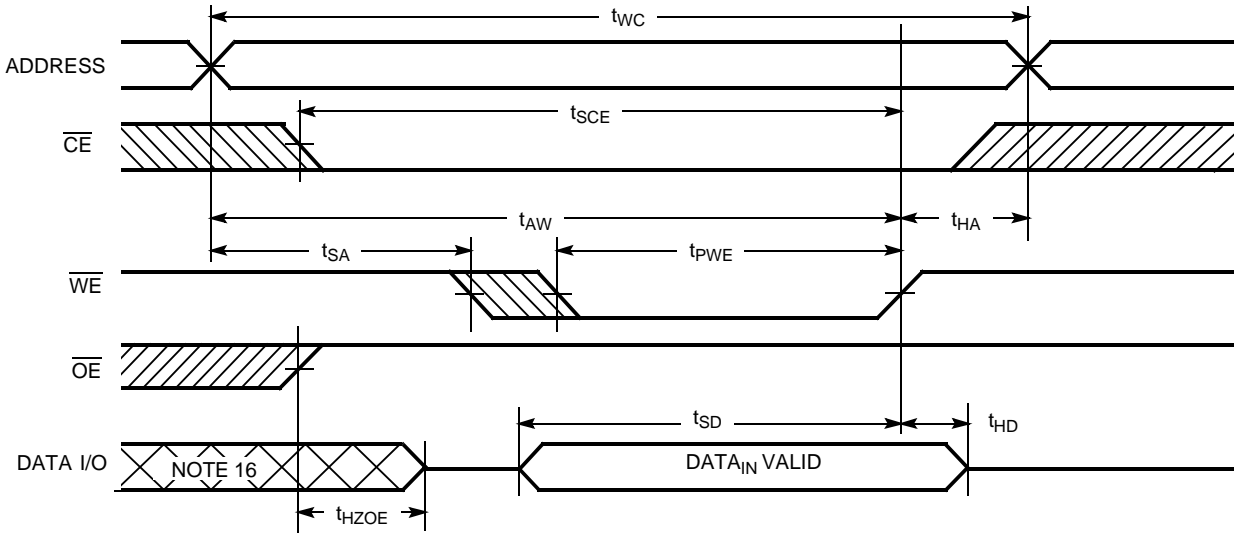

**Write Cycle No. 3 ( $\overline{WE}$  Controlled,  $\overline{OE}$  LOW)<sup>[10, 15]</sup>**

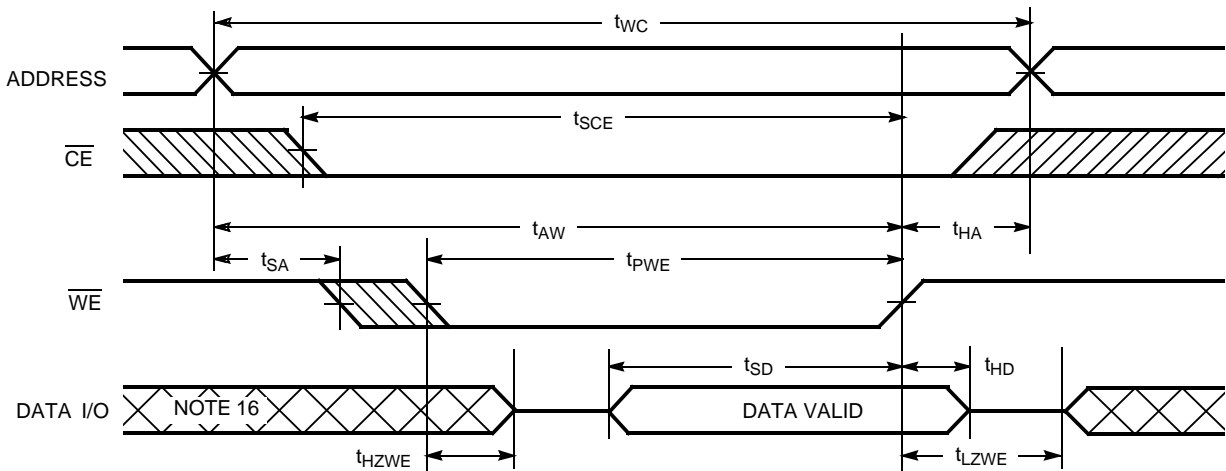

**Truth Table**

CE	OE	WE	I/O <sub>0</sub> -I/O <sub>7</sub>	Mode	Power
H	X	X	High-Z	Power-down	Standby (I <sub>SB</sub> )
L	L	H	Data Out	Read	Active (I <sub>CC</sub> )
L	X	L	Data In	Write	Active (I <sub>CC</sub> )
L	H	H	High-Z	Selected, Outputs Disabled	Active (I <sub>CC</sub> )

**Note:**

16. During this period the I/Os are in the output state and input signals should not be applied.



**CY7C1018CV33**

**Ordering Information**

Speed (ns)	Ordering Code	Package Diagram	Package Type	Operating Range
10	CY7C1018CV33-10VC	51-85041	32-lead 300-mil Molded SOJ	Commercial
12	CY7C1018CV33-12VC		32-lead 300-mil Molded SOJ	Commercial
	CY7C1018CV33-12VXI		32-lead 300-mil Molded SOJ (Pb-Free)	Industrial
15	CY7C1018CV33-15VXC		32-lead 300-mil Molded SOJ (Pb-Free)	Commercial

**Package Diagram**

**32-lead (300-mil) Molded SOJ (51-85041)**

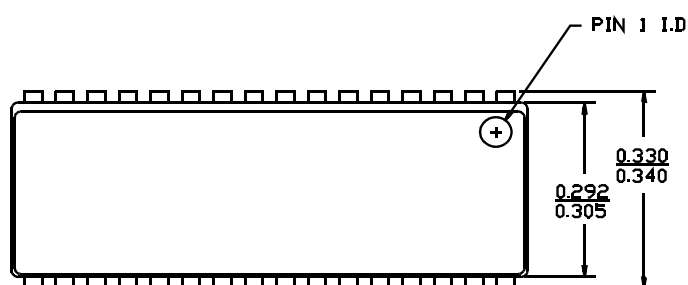

DIMENSIONS IN INCHES MIN.  
MAX.  
LEAD COPLANARITY 0.004 MAX.

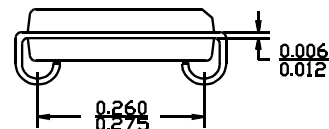
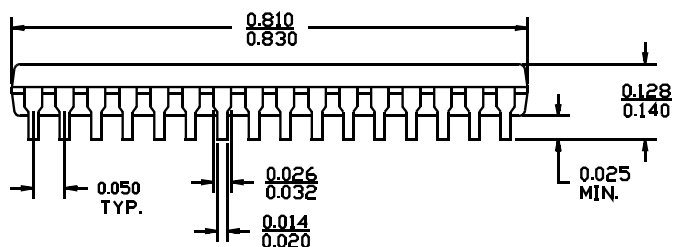

51-85041-A

All product and company names mentioned in this document are the trademarks of their respective holders.



## CY7C1018CV33

### Document History Page

Document Title: CY7C1018CV33 128K x 8 Static RAM Document Number: 38-05131				
REV.	ECN NO.	Issue Date	Orig. of Change	Description of Change
**	109426	12/14/01	HGK	New Data Sheet
*A	113432	04/10/02	NSL	AC Test Loads split based on speed
*B	115046	05/30/02	HGK	I <sub>CC</sub> and I <sub>SB1</sub> modified
*C	116476	09/16/02	CEA	Add applications foot note on data sheet, pg 1
*D	493543	See ECN	NXR	Added Industrial Operating Range Removed 8 ns speed bin from Product offering Changed the description of I <sub>IX</sub> from Input Load Current to Input Leakage Current in DC Electrical Characteristics table Removed I <sub>OS</sub> parameter from DC Electrical Characteristics table Updated the Ordering Information Table