

## Excellent Integrated System Limited

Stocking Distributor

Click to view price, real time Inventory, Delivery & Lifecycle Information:

[Molex Connector Corporation](#)  
[88753-8500](#)

For any questions, you can email us directly:

[sales@integrated-circuit.com](mailto:sales@integrated-circuit.com)

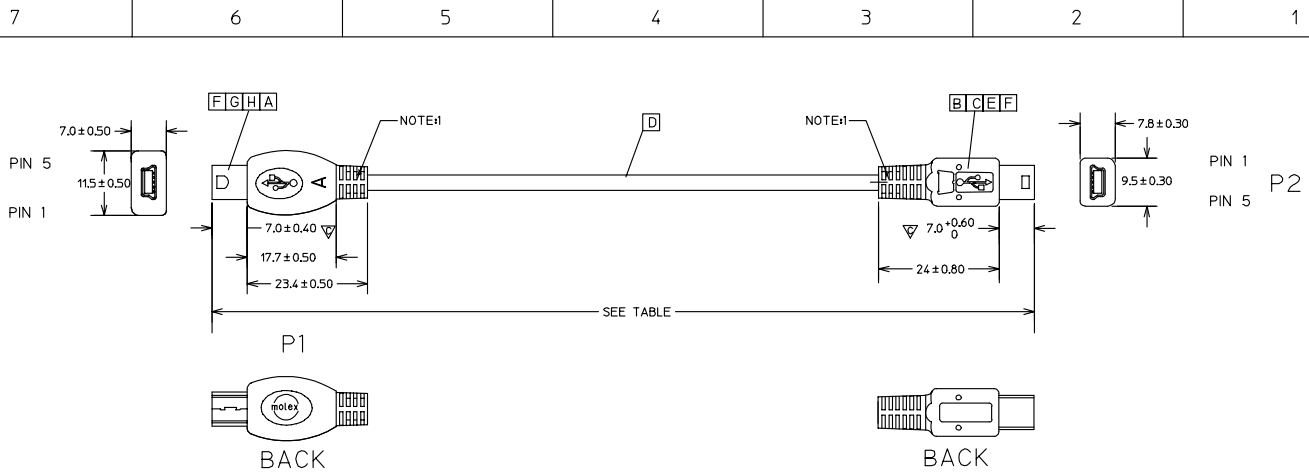

- NOTE:**  
**PHYSICAL**  
 1. MOLDED WITH PVC RESIN (SEE TABLE)  
 2. ANY SURFACE ON MINI A SIDE CAN HAVE TEXTURING UP TO 0.3mm ABOVE OR BELOW THE SURFACE;  
 3. A CIRCULAR AREA AROUND THE LETTER "A" CAN BE RAISED OR LOWERED AS MUCH AS 0.5mm ABOVE THE SURFACE;  
 4. STICK UL LABEL ON EACH CARTON.  
**ELECTRICAL PERFORMANCE:**  
 ALL TEST DUABILITY:0.01 SEC.  
 5.1. DIELECTRONIC STRENGTH:500V DC  
 5.2. INSULATION RESISTANCE:100M OHMS  
 5.3. CONDUCTIVE RESISTANCE:3 OHMS  
 6. ALL COMPONENT MUST MEET RoHS COMPLIANCE.

SHELL	SHELL	SHIELDING	BRAID WIRE	ITEM	DESCRIPTION	L	QTY
4	5	GROUND	BLACK	H	MINI A PLUG REAR SHELL 87899020		1
				G	MINI A PLUG FRONT SHELL 887899019		1
				F	COPPER FOIL 887801114		2
				E	USB SERIES MINI-B PLUG COVER SHIELD 675460000		1
				D	USB CABLE #28/#24 (SEE TABLE)		
				C	USB SERIES MINI-B PLUG SHIELD CASE 675450000		1
				B	MINI-B PLUG 675420008		1
				A	MINI A PLUG HOUSING 887899018		1

ENTER DESCRIPTION		QUALITY SYMBOLS	GENERAL TOLERANCES (UNLESS SPECIFIED)		DIMENSION STYLE		SCALE	DESIGN UNITS		THIRD ANGLE PROJECTION
EC NO:	DATE		mm	INCH	MM ONLY	MM ONLY		METRIC		
EC NO: DG2006-0150	2006/01/09	▼=0 ▽=3	4 PLACES	±---	±---	MM ONLY	---	METRIC		USB MINIA TO MINIB CABLE ASSY  MOLEX INCORPORATED MATERIAL NO. 8875381-86-00/10/20 SD-887538200 DOCUMENT NO. SD-887538200 SHEET NO. 1 OF 2
DRWN: JFZHENG	2006/01/09		3 PLACES	±---	±---	DRAWN BY	DATE			
CHKD: JFZHENG	2006/01/09		2 PLACES	±---	±---	CHECKED BY	DATE			
APPR: DDLUO	2006/01/16		1 PLACE	±---	±---	APPROVED BY	DATE			
A		REV	ANGULAR ±1/2°		DRAFT WHERE APPLICABLE MUST REMAIN WITHIN DIMENSIONS		THIS DRAWING CONTAINS INFORMATION THAT IS PROPRIETARY TO MOLEX INCORPORATED AND SHOULD NOT BE USED WITHOUT WRITTEN PERMISSION			

7 6 5 4 3 2 1

TABLE

88753-8610	2000±30	USB MINI-A TO MINI-B FROST WHT V1.1	88780-8249	88780-0043
88753-8510	1800±30	USB MINI-A TO MINI-B FROST WHT V1.1	88780-8249	88780-0043
88753-8410	1500±30	USB MINI-A TO MINI-B FROST WHT V1.1	88780-8249	88780-0043
88753-8310	1200±30	USB MINI-A TO MINI-B FROST WHT V1.1	88780-8249	88780-0043
88753-8210	1000±30	USB MINI-A TO MINI-B FROST WHT V1.1	88780-8249	88780-0043
88753-8110	800±30	USB MINI-A TO MINI-B FROST WHT V1.1	88780-8249	88780-0043
88753-8602	2000±30	USB MINI-A TO MINI-B BLACK V2.0	88780-8248	88780-0019
88753-8502	1800±30	USB MINI-A TO MINI-B BLACK V2.0	88780-8248	88780-0019
88753-8402	1500±30	USB MINI-A TO MINI-B BLACK V2.0	88780-8248	88780-0019
88753-8302	1200±30	USB MINI-A TO MINI-B BLACK V2.0	88780-8248	88780-0019
88753-8202	1000±30	USB MINI-A TO MINI-B BLACK V2.0	88780-8248	88780-0019
88753-8102	800±30	USB MINI-A TO MINI-B BLACK V2.0	88780-8248	88780-0019
88753-8600	2000±30	USB MINI-A TO MINI-B FROST WHT V2.0	88780-8243	88780-0043
88753-8500	1800±30	USB MINI-A TO MINI-B FROST WHT V2.0	88780-8243	88780-0043
88753-8400	1500±30	USB MINI-A TO MINI-B FROST WHT V2.0	88780-8243	88780-0043
88753-8300	1200±30	USB MINI-A TO MINI-B FROST WHT V2.0	88780-8243	88780-0043
88753-8200	1000±30	USB MINI-A TO MINI-B FROST WHT V2.0	88780-8243	88780-0043
88753-8100	800±30	USB MINI-A TO MINI-B FROST WHT V2.0	88780-8243	88780-0043
MX P/N	CABLE LENGTH	DESCRIPTION	CABLE P/N	RESIN P/N

ENTER DESCRIPTION EC NO: DG2006-0150 DRAWN: JFZHENG CHKD: JFZHENG APPR: DOLUO 2006/01/09 2006/01/09 2006/01/16	QUALITY SYMBOLS ▽=0 ▽=3	GENERAL TOLERANCES (UNLESS SPECIFIED)		DIMENSION STYLE MM ONLY		SCALE ---	DESIGN UNITS METRIC	THIRD ANGLE PROJECTION	
			mm	INCH	DRAWN BY JFZHENG	DATE 2006/01/06	TITLE USB MINIA TO MINIB CABLE ASSY		
		4 PLACES	±---	±---	CHECKED BY JFZHENG	DATE 2006/01/06	MOLEX MOLEX INCORPORATED		
		3 PLACES	±---	±---	APPROVED BY DOLUO	DATE 2006/01/06	DOCUMENT NO. SD-887538200		
DRAFT WHERE APPLICABLE MUST REMAIN WITHIN DIMENSIONS		ANGULAR ±1/2°		MATERIAL NO. 8875381-86-00/10/20		SHEET NO. 2 OF 2			
THIS DRAWING CONTAINS INFORMATION THAT IS PROPRIETARY TO MOLEX INCORPORATED AND SHOULD NOT BE USED WITHOUT WRITTEN PERMISSION									

6 5 4 3 2 1