

Excellent Integrated System Limited

Stocking Distributor

Click to view price, real time Inventory, Delivery & Lifecycle Information:

[BUD Industries, Inc.](#)
[CN-5709](#)

For any questions, you can email us directly:

sales@integrated-circuit.com

THE INFORMATION CONTAINED IN THIS DRAWING IS THE SOLE PROPERTY OF BUD INDUSTRIES INC. ANY REPRODUCTION IN PART OR WHOLE WITHOUT THE WRITTEN PERMISSION OF BUD INDUSTRIES INC. IS PROHIBITED.

CN-5709	
ISSUE	REVISIONS

MATERIAL - ALUMINUM ALLOY #ADC-12
 FINISH - NATURAL (CONTACT BUD FACTORY FOR ALTERNATE FINISHES)
 GASKET - RATED IP65 NEOPRENE, SELF-ADHESIVE, 3mm THICK, COLOR BLACK
 SCREWS - STAINLESS STEEL, M3.5 x 12mm LG., CSK. HEAD, SELF-THREADING

ALL HOLE DIAMETERS HAVE $\pm .005$ TOLERANCE.
 ALL OTHER DIMENSIONS HAVE $\pm .015$ TOLERANCE.
 ENCLOSURES ARE SHIPPED UNASSEMBLED WITH ALL ITEMS SHOWN.

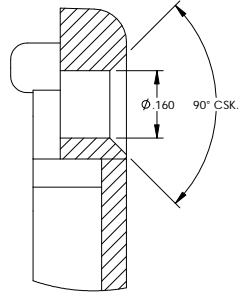
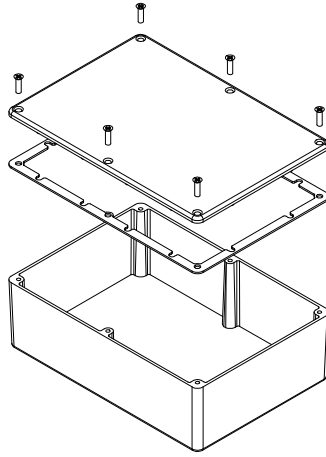

DETAIL D
SCALE 6 : 1

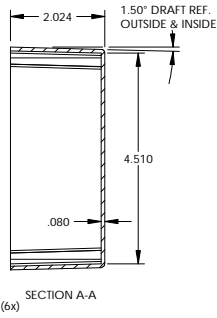
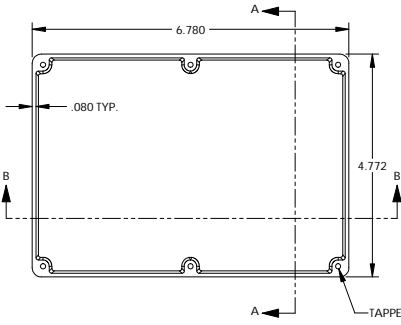

SECTION A-A

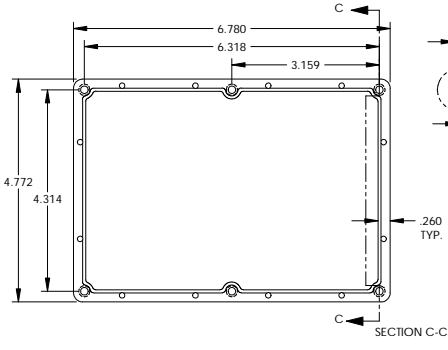

SECTION C-C

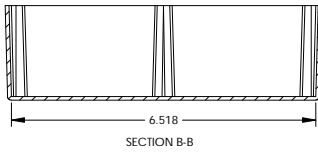

SECTION B-B

PARTS LIST			
QTY	USED ON	DESCRIPTION	REV

BUD INDUSTRIES INC.	
DIE CAST ALUMINUM ENCLOSURE	
DATE: 3-31-06	REV:
SCALE:	
CAD FILE:	