

Excellent Integrated System Limited

Stocking Distributor

Click to view price, real time Inventory, Delivery & Lifecycle Information:

[NXP Semiconductors/Freescale Semiconductor, Inc.](#)
[74LVT16373ADGG.512](#)

For any questions, you can email us directly:

sales@integrated-circuit.com

DATA SHEET

74LVT16373A

**3.3V LVT 16-bit transparent D-type latch
(3-State)**

Product specification
Supersedes data of 1994 Dec 15
IC23 Data Handbook

1998 Feb 19

3.3V 16-bit transparent D-type latch (3-State)

74LVT16373A

FEATURES

- 16-bit transparent latch
- 3-State buffers
- Output capability: +64mA/-32mA
- TTL input and output switching levels
- Input and output interface capability to systems at 5V supply
- Bus-hold data inputs eliminate the need for external pull-up resistors to hold unused inputs
- Live insertion/extraction permitted
- Power-up reset
- Power-up 3-State
- No bus current loading when output is tied to 5V bus
- Latch-up protection exceeds 500mA per JEDEC Std 17
- ESD protection exceeds 2000V per MIL STD 883 Method 3015 and 200V per Machine Model

DESCRIPTION

The 74LVT16373A is a high-performance BiCMOS product designed for V_{CC} operation at 3.3V.

This device is a 16-bit transparent D-type latch with non-inverting 3-State bus compatible outputs. The device can be used as two 8-bit latches or one 16-bit latch. When enable (E) input is High, the Q outputs follow the data (D) inputs. When enable is taken Low, the Q outputs are latched at the levels of the D inputs one setup time prior to the High-to-Low transition.

QUICK REFERENCE DATA

| SYMBOL | PARAMETER | CONDITIONS $T_{amb} = 25^{\circ}C$ | TYPICAL | UNIT |
|------------------------|---------------------------------|---------------------------------------|---------|---------|
| t_{PLH} t_{PHL} | Propagation delay nDx to nQx | $C_L = 50pF$; $V_{CC} = 3.3V$ | 1.9 | ns |
| C_{IN} | Input capacitance | $V_I = 0V$ or 3.0V | 3 | pF |
| C_{OUT} | Output capacitance | Outputs disabled; $V_O = 0V$ or 3.0V | 9 | pF |
| I_{CCZ} | Total supply current | Outputs disabled; $V_{CC} = 3.6V$ | 70 | μA |

ORDERING INFORMATION

| PACKAGES | TEMPERATURE RANGE | OUTSIDE NORTH AMERICA | NORTH AMERICA | DWG NUMBER |
|------------------------------|-------------------|-----------------------|---------------|------------|
| 48-Pin Plastic SSOP Type III | -40°C to +85°C | 74LVT16373A DL | VT16373A DL | SOT370-1 |
| 48-Pin Plastic TSSOP Type II | -40°C to +85°C | 74LVT16373A DGG | VT16373A DGG | SOT362-1 |

LOGIC SYMBOL

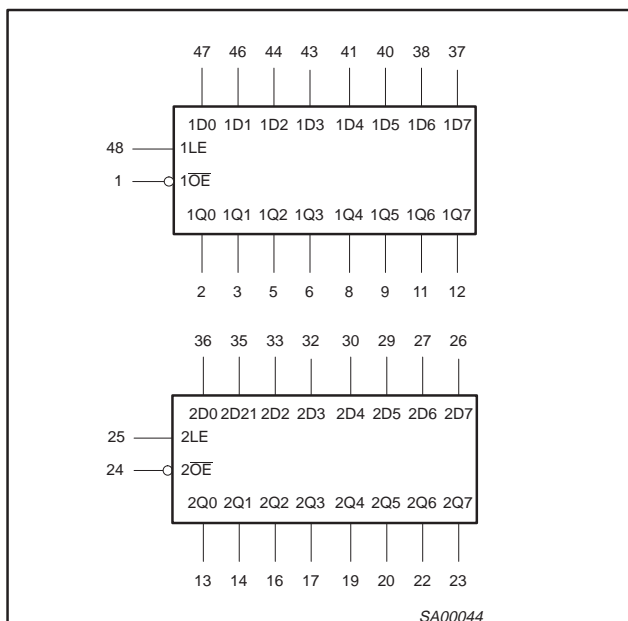

PIN DESCRIPTION

| PIN NUMBER | SYMBOL | FUNCTION |
|---|------------------------|--------------------------------------|
| 47, 46, 44, 43, 41, 40, 38, 37, 36, 35, 33, 32, 30, 29, 27, 26 | 1D0 – 1D7 2D0 – 2D7 | Data inputs |
| 2, 3, 5, 6, 8, 9, 11, 12, 13, 14, 16, 17, 19, 20, 22, 23 | 1Q0 – 1Q7 2Q0 – 2Q7 | Data outputs |
| 1, 24 | 1OE, 2OE | Output enable inputs (active-Low) |
| 48, 25 | 1E, 2E | Enable inputs (active-High) |
| 4, 10, 15, 21, 28, 34, 39, 45 | GND | Ground (0V) |
| 7, 18, 31, 42 | V_{CC} | Positive supply voltage |

3.3V 16-bit transparent D-type latch (3-State)

74LVT16373A

LOGIC SYMBOL (IEEE/IEC)

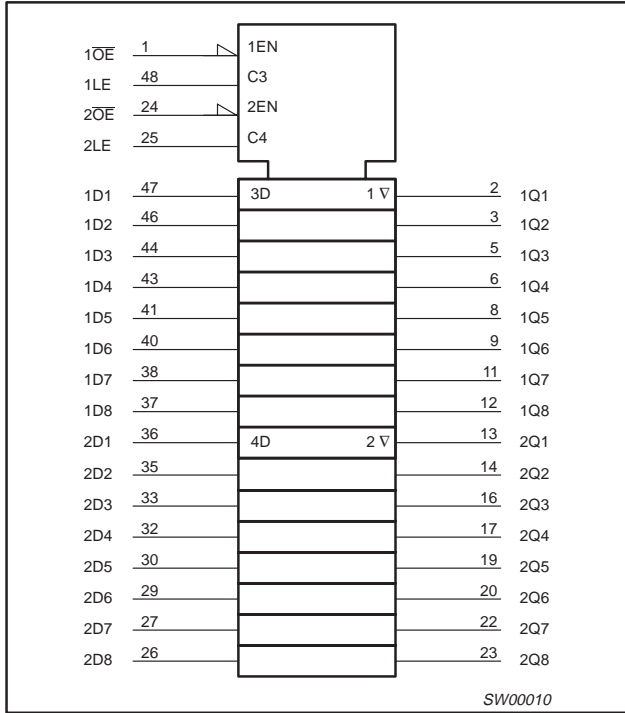

PIN CONFIGURATION

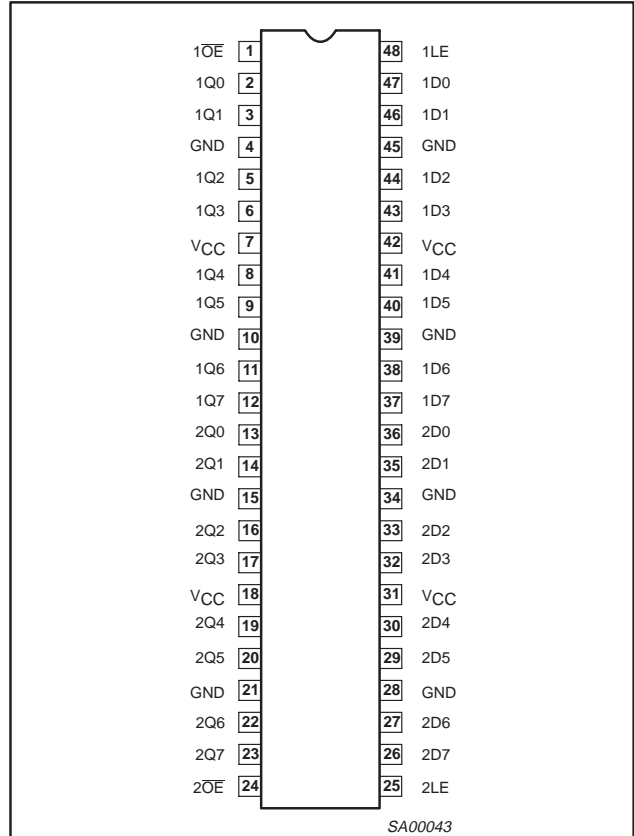

LOGIC DIAGRAM

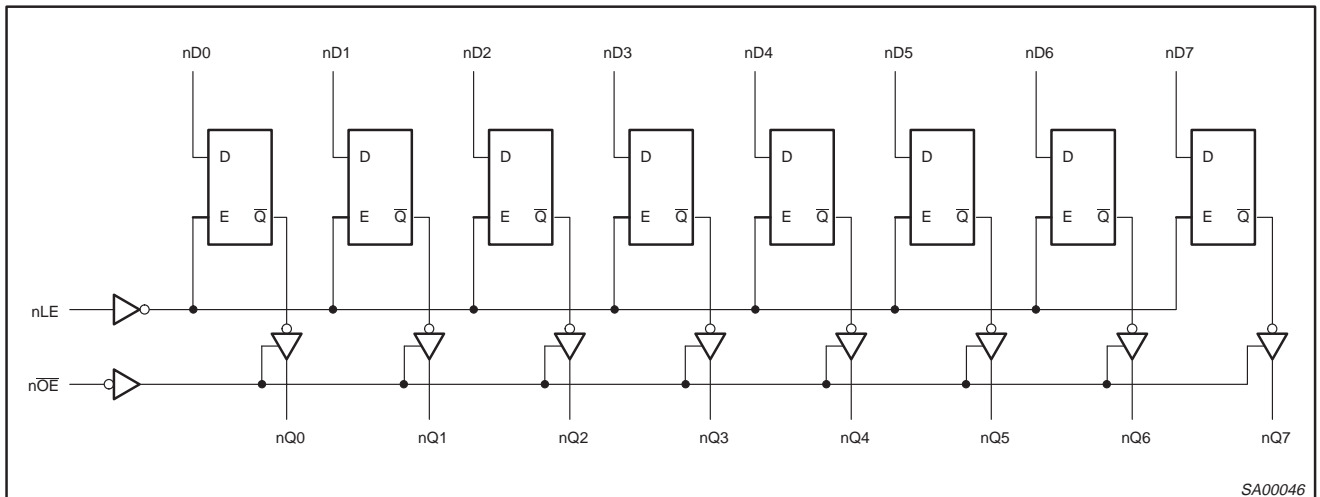

3.3V 16-bit transparent D-type latch (3-State)

74LVT16373A

FUNCTION TABLE

| INPUTS | | | INTERNAL REGISTER | OUTPUTS | OPERATING MODE |
|--------|--------|----------|-------------------|-----------|--------------------------|
| nOE | nE | nDx | | nQ0 – nQ7 | |
| L L | H H | L H | L H | L H | Enable and read register |
| L L | ↓ ↓ | l h | L H | L H | Latch and read register |
| L | L | X | NC | NC | Hold |
| H H | L H | X nDx | NC nDx | Z Z | Disable outputs |

H = High voltage level

h = High voltage level one set-up time prior to the High-to-Low E transition

L = Low voltage level

l = Low voltage level one set-up time prior to the High-to-Low E transition

NC= No change

X = Don't care

Z = High impedance "off" state

↓ = High-to-Low E transition

ABSOLUTE MAXIMUM RATINGS^{1, 2}

| SYMBOL | PARAMETER | CONDITIONS | RATING | UNIT |
|------------------|--------------------------------|-----------------------------|--------------|------|
| V _{CC} | DC supply voltage | | -0.5 to +4.6 | V |
| I _{IK} | DC input diode current | V _I < 0 | -50 | mA |
| V _I | DC input voltage ³ | | -0.5 to +7.0 | V |
| I _{OK} | DC output diode current | V _O < 0 | -50 | mA |
| V _{OUT} | DC output voltage ³ | Output in Off or High state | -0.5 to +7.0 | V |
| I _{OUT} | DC output current | Output in Low state | 128 | mA |
| | | Output in High state | -64 | |
| T _{stg} | Storage temperature range | | -65 to +150 | °C |

NOTES:

- Stresses beyond those listed may cause permanent damage to the device. These are stress ratings only and functional operation of the device at these or any other conditions beyond those indicated under "recommended operating conditions" is not implied. Exposure to absolute-maximum-rated conditions for extended periods may affect device reliability.
- The performance capability of a high-performance integrated circuit in conjunction with its thermal environment can create junction temperatures which are detrimental to reliability. The maximum junction temperature of this integrated circuit should not exceed 150°C.
- The input and output negative voltage ratings may be exceeded if the input and output clamp current ratings are observed.

RECOMMENDED OPERATING CONDITIONS

| SYMBOL | PARAMETER | LIMITS | | UNIT |
|------------------|--|--------|-----|------|
| | | MIN | MAX | |
| V _{CC} | DC supply voltage | 2.7 | 3.6 | V |
| V _I | Input voltage | 0 | 5.5 | V |
| V _{IH} | High-level input voltage | 2.0 | | V |
| V _{IL} | Input voltage | | 0.8 | V |
| I _{OH} | High-level output current | | -32 | mA |
| I _{OL} | Low-level output current | | 32 | mA |
| | Low-level output current; current duty cycle ≤ 50%; f ≥ 1kHz | | 64 | |
| Δt/Δv | Input transition rise or fall rate; Outputs enabled | | 10 | ns/V |
| T _{amb} | Operating free-air temperature range | -40 | +85 | °C |

3.3V 16-bit transparent D-type latch (3-State)

74LVT16373A

DC ELECTRICAL CHARACTERISTICS

| SYMBOL | PARAMETER | TEST CONDITIONS | LIMITS | | | UNIT |
|--------------------|--|---|------------------------|------------------|------|------|
| | | | Temp = -40°C to +85°C | | | |
| | | | MIN | TYP ¹ | MAX | |
| V _{IK} | Input clamp voltage | V _{CC} = 2.7V; I _{IK} = -18mA | | -0.85 | -1.2 | V |
| V _{OH} | High-level output voltage | V _{CC} = 2.7 to 3.6V; I _{OH} = -100μA | V _{CC} -0.2 | V _{CC} | | V |
| | | V _{CC} = 2.7V; I _{OH} = -8mA | 2.4 | 2.5 | | |
| | | V _{CC} = 3.0V; I _{OH} = -32mA | 2.0 | 2.3 | | |
| V _{OL} | Low-level output voltage | V _{CC} = 2.7V; I _{OL} = 100μA | | 0.07 | 0.2 | V |
| | | V _{CC} = 2.7V; I _{OL} = 24mA | | 0.3 | 0.5 | |
| | | V _{CC} = 3.0V; I _{OL} = 16mA | | 0.25 | 0.4 | |
| | | V _{CC} = 3.0V; I _{OL} = 32mA | | 0.3 | 0.5 | |
| | | V _{CC} = 3.0V; I _{OL} = 64mA | | 0.4 | 0.55 | |
| V _{RST} | Power-up output Low voltage ⁵ | V _{CC} = 3.6V; I _O = 1mA; V _I = GND or V _{CC} | | 0.1 | 0.55 | V |
| I _I | Input leakage current | V _{CC} = 3.6V; V _I = V _{CC} or GND | Control pins | 0.1 | ±1 | μA |
| | | V _{CC} = 0 or 3.6V; V _I = 5.5V | | 0.4 | 10 | |
| | | V _{CC} = 3.6V; V _I = V _{CC} | Data pins ⁴ | 0.1 | 1 | |
| | | V _{CC} = 3.6V; V _I = 0 | | -0.4 | -5 | |
| I _{OFF} | Output off current | V _{CC} = 0V; V _I or V _O = 0 to 4.5V | | 0.1 | ±100 | μA |
| I _{HOLD} | Bus Hold current D inputs ⁷ | V _{CC} = 3V; V _I = 0.8V | | 75 | 135 | μA |
| | | V _{CC} = 3V; V _I = 2.0V | | -75 | -135 | |
| | | V _{CC} = 0V to 3.6V; V _{CC} = 3.6V | | ±500 | | |
| I _{EX} | Current into an output in the High state when V _O > V _{CC} | V _O = 5.5V; V _{CC} = 3.0V | | 50 | 125 | μA |
| I _{PU/PD} | Power up/down 3-State output current ³ | V _{CC} ≤ 1.2V; V _O = 0.5V to V _{CC} ; V _I = GND or V _{CC} ; OE/OE = Don't care | | 1 | ±100 | μA |
| I _{OZH} | 3-State output High current | V _{CC} = 3.6V; V _O = 3.0V; V _I = V _{IH} or V _{IL} | | 0.5 | 5 | μA |
| I _{OZL} | 3-State output Low current | V _{CC} = 3.6V; V _O = 0.5V; V _I = V _{IH} or V _{IL} | | 0.5 | -5 | |
| I _{CCH} | Quiescent supply current | V _{CC} = 3.6V; Outputs High, V _I = GND or V _{CC} , I _O = 0 | | 0.07 | 0.12 | mA |
| I _{CCL} | | V _{CC} = 3.6V; Outputs Low, V _I = GND or V _{CC} , I _O = 0 | | 4.0 | 6 | |
| I _{CCZ} | | V _{CC} = 3.6V; Outputs Disabled; V _I = GND or V _{CC} , I _O = 0 ⁶ | | 0.07 | 0.12 | |
| ΔI _{CC} | Additional supply current per input pin ² | V _{CC} = 3V to 3.6V; One input at V _{CC} -0.6V, Other inputs at V _{CC} or GND | | 0.1 | 0.2 | mA |

NOTES:

- All typical values are at V_{CC} = 3.3V and T_{amb} = 25°C.
- This is the increase in supply current for each input at the specified voltage level other than V_{CC} or GND.
- This parameter is valid for any V_{CC} between 0V and 1.2V with a transition time of up to 10msec. From V_{CC} = 1.2V to V_{CC} = 3.3V ± 0.3V a transition time of 100μsec is permitted. This parameter is valid for T_{amb} = 25°C only.
- Unused pins at V_{CC} or GND.
- For valid test results, data must not be loaded into the flip-flops (or latches) after applying power.
- I_{CCZ} is measured with outputs pulled to V_{CC} or GND.
- This is the bus hold overdrive current required to force the input to the opposite logic state.

3.3V 16-bit transparent D-type latch (3-State)

74LVT16373A

AC CHARACTERISTICS

GND = 0V; $t_R = t_F = 2.5\text{ns}$; $C_L = 50\text{pF}$; $R_L = 500\Omega$; $T_{\text{amb}} = -40^\circ\text{C}$ to $+85^\circ\text{C}$.

| SYMBOL | PARAMETER | WAVEFORM | LIMITS | | | | UNIT |
|------------------------|--|----------|--|------------------|------------|------------------------|------|
| | | | $V_{CC} = 3.3\text{V} \pm 0.3\text{V}$ | | | $V_{CC} = 2.7\text{V}$ | |
| | | | MIN | TYP ¹ | MAX | MAX | |
| t_{PLH} t_{PHL} | Propagation delay nDx to nQx | 2 | 0.5 0.5 | 1.8 1.9 | 3.9 3.9 | 4.5 4.5 | ns |
| t_{PLH} t_{PHL} | Propagation delay nE to nQx | 1 | 0.5 0.5 | 2.1 2.2 | 4.8 4.8 | 5.4 5.4 | ns |
| t_{PZH} t_{PZL} | Output enable time to High and Low level | 4 5 | 0.1 0.1 | 2.8 2.6 | 4.5 4.3 | 5.1 4.7 | ns |
| t_{PHZ} t_{PLZ} | Output disable time from High and Low Level | 4 5 | 0.1 0.1 | 3.3 3.0 | 4.5 4.3 | 5.1 4.7 | ns |

NOTE:

1. All typical values are at $V_{CC} = 3.3\text{V}$ and $T_{\text{amb}} = 25^\circ\text{C}$.

AC SETUP REQUIREMENTS

GND = 0V; $t_R = t_F = 2.5\text{ns}$; $C_L = 50\text{pF}$; $R_L = 500\Omega$; $T_{\text{amb}} = -40^\circ\text{C}$ to $+85^\circ\text{C}$.

| SYMBOL | PARAMETER | WAVEFORM | LIMITS | | | UNIT |
|----------------------|-------------------------|----------|--|------------|------------------------|------|
| | | | $V_{CC} = 3.3\text{V} \pm 0.3\text{V}$ | | $V_{CC} = 2.7\text{V}$ | |
| | | | MIN | TYP | MIN | |
| $t_S(H)$ $t_S(L)$ | Setup time nDx to nE | 3 | 1.5 2.0 | 0.1 0.2 | 1.0 2.0 | ns |
| $t_H(H)$ $t_H(L)$ | Hold time nDx to nE | 3 | 1.0 1.5 | 0 0 | 1.0 2.0 | ns |
| $t_W(H)$ | nE pulse width High | 1 | 1.5 | 0.5 | 1.5 | ns |

AC WAVEFORMS

For all waveforms, $V_M = 1.5\text{V}$.

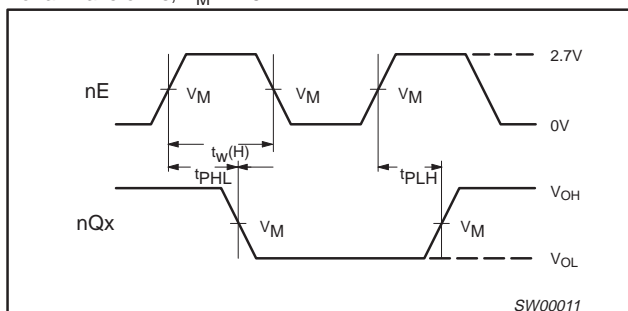

Waveform 1. Propagation Delay, Enable to Output, and Enable Pulse Width

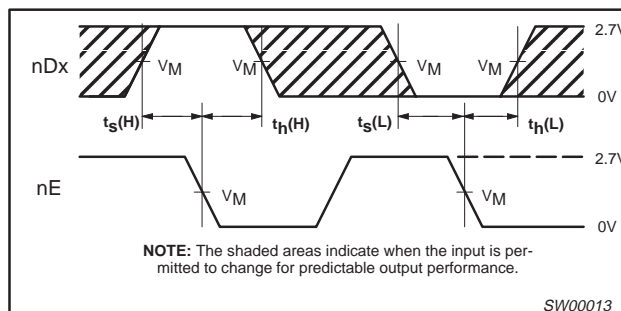

Waveform 3. Data Setup and Hold Times

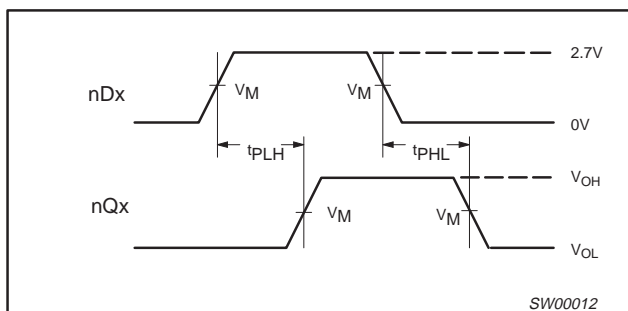

Waveform 2. Propagation Delay for Data to Outputs

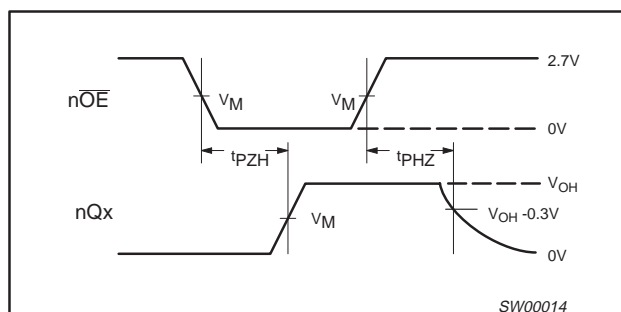

Waveform 4. 3-State Output Enable time to High Level and Output Disable Time from High Level

3.3V 16-bit transparent D-type latch (3-State)

74LVT16373A

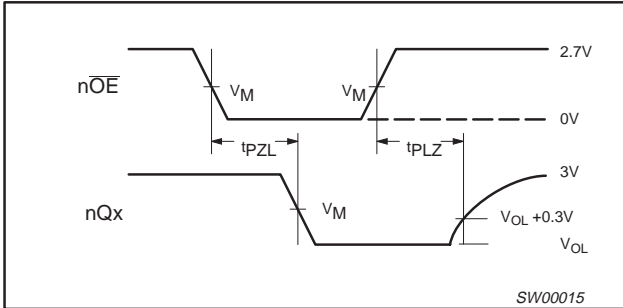

Waveform 5. 3-State Output Enable Time to Low Level and Output Disable Time from Low Level

TEST CIRCUIT AND WAVEFORMS

Test Circuit for 3-State Outputs

| SWITCH POSITION | |
|-----------------|--------|
| TEST | SWITCH |
| tPHZ/tPZH | GND |
| tPLZ/tPZL | 6V |
| tPLH/tPHL | open |

DEFINITIONS
 RL = Load resistor; see AC CHARACTERISTICS for value.
 CL = Load capacitance includes jig and probe capacitance; see AC CHARACTERISTICS for value.
 RT = Termination resistance should be equal to ZOUT of pulse generators.

Input Pulse Definition

VM = 1.5V

| FAMILY | INPUT PULSE REQUIREMENTS | | | | |
|---------|--------------------------|-----------|-------|--------|--------|
| | Amplitude | Rep. Rate | tW | tR | tF |
| 74LVT16 | 2.7V | ≤10MHz | 500ns | ≤2.5ns | ≤2.5ns |

SW00003

3.3V LVT 16-bit transparent D-type latch (3-State)

74LVT16373A

SSOP48: plastic shrink small outline package; 48 leads; body width 7.5 mm

SOT370-1

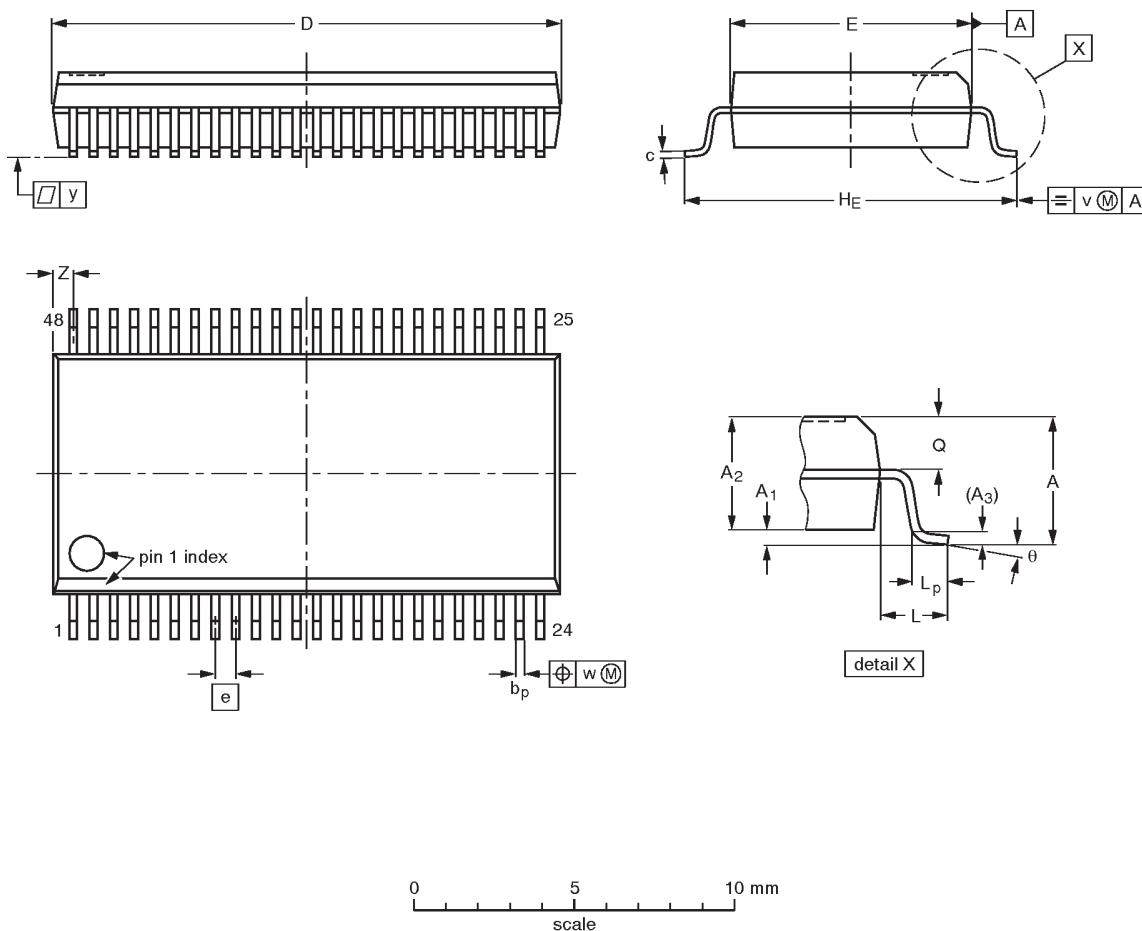

DIMENSIONS (mm are the original dimensions)

| UNIT | A _{max.} | A ₁ | A ₂ | A ₃ | b _p | c | D ⁽¹⁾ | E ⁽¹⁾ | e | H _E | L | L _p | Q | v | w | y | Z ⁽¹⁾ | θ |
|------|-------------------|----------------|----------------|----------------|----------------|--------------|------------------|------------------|-------|----------------|-----|----------------|------------|------|------|-----|------------------|----------|
| mm | 2.8 | 0.4 0.2 | 2.35 2.20 | 0.25 | 0.3 0.2 | 0.22 0.13 | 16.00 15.75 | 7.6 7.4 | 0.635 | 10.4 10.1 | 1.4 | 1.0 0.6 | 1.2 1.0 | 0.25 | 0.18 | 0.1 | 0.85 0.40 | 8° 0° |

Note

1. Plastic or metal protrusions of 0.25 mm maximum per side are not included.

| OUTLINE VERSION | REFERENCES | | | | EUROPEAN PROJECTION | ISSUE DATE |
|-----------------|------------|----------|------|--|---------------------|----------------------|
| | IEC | JEDEC | EIAJ | | | |
| SOT370-1 | | MO-118AA | | | | 93-11-02 95-02-04 |

3.3V LVT 16-bit transparent D-type latch (3-State)

74LVT16373A

TSSOP48: plastic thin shrink small outline package; 48 leads; body width 6.1mm

SOT362-1

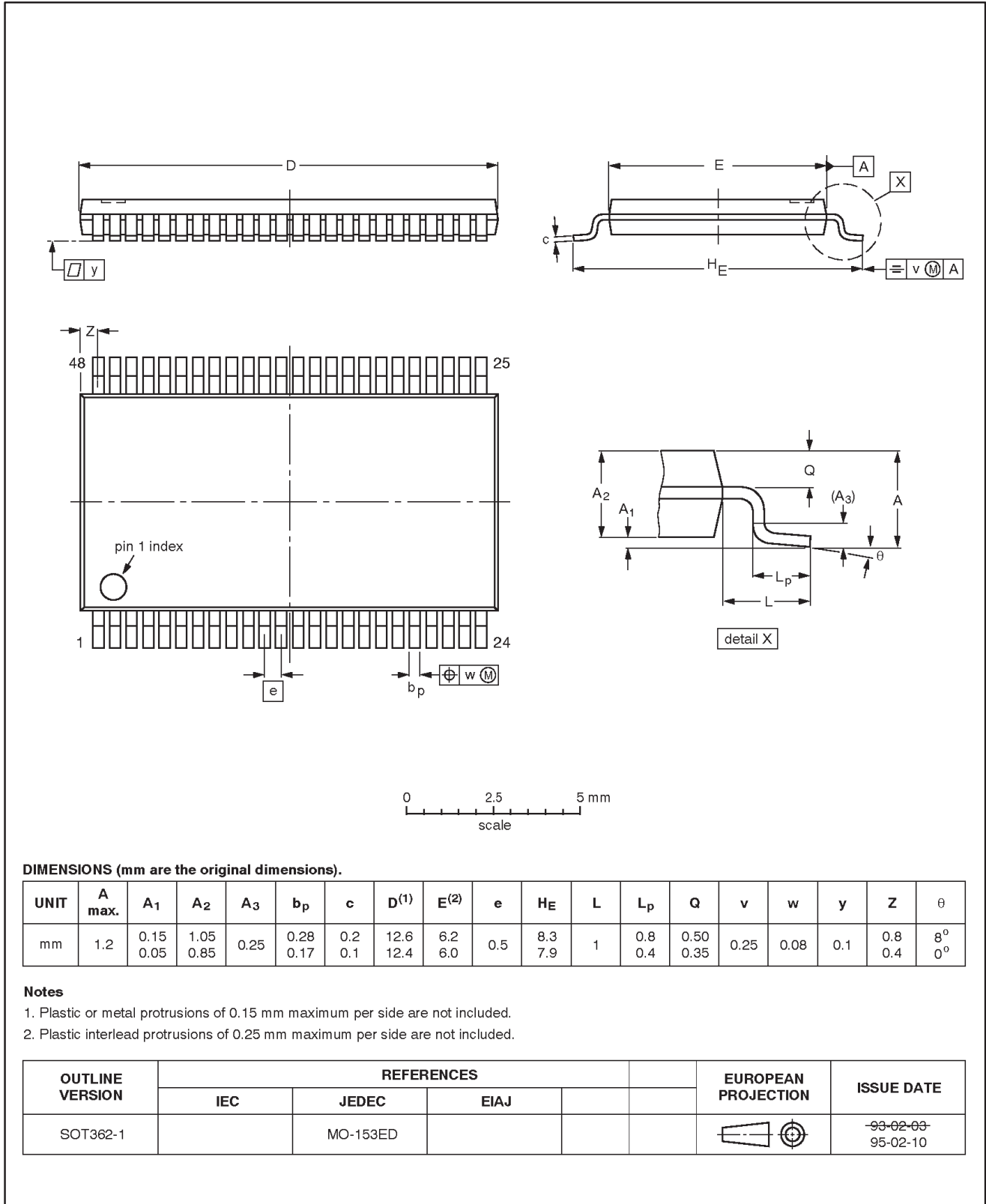

DIMENSIONS (mm are the original dimensions).

| UNIT | A max. | A ₁ | A ₂ | A ₃ | b _p | c | D ⁽¹⁾ | E ⁽²⁾ | e | H _E | L | L _p | Q | v | w | y | Z | θ |
|------|--------|----------------|----------------|----------------|----------------|------------|------------------|------------------|-----|----------------|---|----------------|--------------|------|------|-----|------------|----------|
| mm | 1.2 | 0.15 0.05 | 1.05 0.85 | 0.25 | 0.28 0.17 | 0.2 0.1 | 12.6 12.4 | 6.2 6.0 | 0.5 | 8.3 7.9 | 1 | 0.8 0.4 | 0.50 0.35 | 0.25 | 0.08 | 0.1 | 0.8 0.4 | 8° 0° |

Notes

1. Plastic or metal protrusions of 0.15 mm maximum per side are not included.
2. Plastic interlead protrusions of 0.25 mm maximum per side are not included.

| OUTLINE VERSION | REFERENCES | | | | EUROPEAN PROJECTION | ISSUE DATE |
|-----------------|------------|----------|------|--|---------------------|----------------------|
| | IEC | JEDEC | EIAJ | | | |
| SOT362-1 | | MO-153ED | | | | 93-02-03 95-02-10 |

3.3V LVT 16-bit transparent D-type latch
 (3-State)

74LVT16373A

Data sheet status

| Data sheet status | Product status | Definition [1] |
|---------------------------|----------------|--|
| Objective specification | Development | This data sheet contains the design target or goal specifications for product development. Specification may change in any manner without notice. |
| Preliminary specification | Qualification | This data sheet contains preliminary data, and supplementary data will be published at a later date. Philips Semiconductors reserves the right to make changes at any time without notice in order to improve design and supply the best possible product. |
| Product specification | Production | This data sheet contains final specifications. Philips Semiconductors reserves the right to make changes at any time without notice in order to improve design and supply the best possible product. |

[1] Please consult the most recently issued datasheet before initiating or completing a design.

Definitions

Short-form specification — The data in a short-form specification is extracted from a full data sheet with the same type number and title. For detailed information see the relevant data sheet or data handbook.

Limiting values definition — Limiting values given are in accordance with the Absolute Maximum Rating System (IEC 134). Stress above one or more of the limiting values may cause permanent damage to the device. These are stress ratings only and operation of the device at these or at any other conditions above those given in the Characteristics sections of the specification is not implied. Exposure to limiting values for extended periods may affect device reliability.

Application information — Applications that are described herein for any of these products are for illustrative purposes only. Philips Semiconductors make no representation or warranty that such applications will be suitable for the specified use without further testing or modification.

Disclaimers

Life support — These products are not designed for use in life support appliances, devices or systems where malfunction of these products can reasonably be expected to result in personal injury. Philips Semiconductors customers using or selling these products for use in such applications do so at their own risk and agree to fully indemnify Philips Semiconductors for any damages resulting from such application.

Right to make changes — Philips Semiconductors reserves the right to make changes, without notice, in the products, including circuits, standard cells, and/or software, described or contained herein in order to improve design and/or performance. Philips Semiconductors assumes no responsibility or liability for the use of any of these products, conveys no license or title under any patent, copyright, or mask work right to these products, and makes no representations or warranties that these products are free from patent, copyright, or mask work right infringement, unless otherwise specified.

Philips Semiconductors
 811 East Arques Avenue
 P.O. Box 3409
 Sunnyvale, California 94088-3409
 Telephone 800-234-7381

© Copyright Philips Electronics North America Corporation 1998
 All rights reserved. Printed in U.S.A.

print code

Date of release: 05-96

Document order number:

9397-750-03554

Let's make things better.

