

## Excellent Integrated System Limited

Stocking Distributor

Click to view price, real time Inventory, Delivery & Lifecycle Information:

[Lumex, Inc.](#)  
[SML-LX1610UWC/A](#)

For any questions, you can email us directly:

[sales@integrated-circuit.com](mailto:sales@integrated-circuit.com)

UNCONTROLLED DOCUMENT

PART NUMBER		REV.
SML-LX1610UWC/A		A
REV.	E.C.N. NUMBER AND REVISION COMMENTS	DATE
A	E.C.N. #11388.	01.11.07

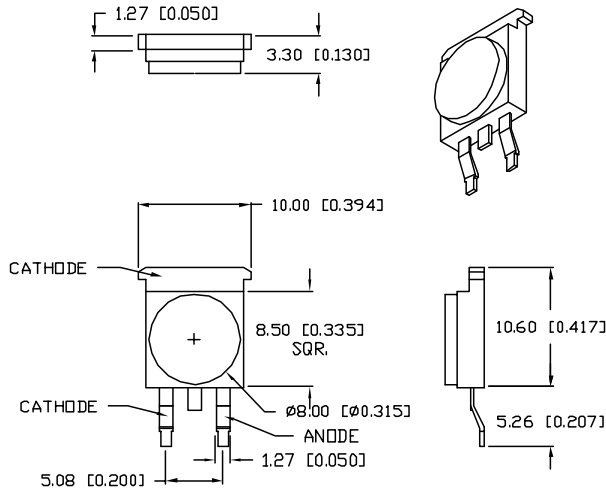

ELECTRO-OPTICAL CHARACTERISTICS  $T_A=25^{\circ}\text{C}$   $I_f=350\text{mA}$

PARAMETER	SYMBOL	MIN	TYP	MAX	UNITS	TEST COND
PEAK WAVELENGTH					nm	
FORWARD VOLTAGE	$V_f$		3.5	4.0	V	$I_f=350\text{mA}$
REVERSE VOLTAGE	$V_r$	5			V	$I_f=10\mu\text{A}$
AXIAL INTENSITY(*1)	$I_v$		30		lm	$I_f=350\text{mA}$
COLOR TEMP.		3000		9000		$I_f=350\text{mA}$
VIEWING ANGLE			110		$2x \theta_{\text{max}}$	
EMITTED COLOR:		WHITE				
EPOXY LENS FINISH:		WATER CLEAR				

\*1. AXIAL INTENSITY TESTING CONDITION: 550nm WAVELENGTH.  
 \*2. THE ICI STANDARD COLORIMETRIC SYSTEM.

LIMITS OF SAFE OPERATION AT 25°C

PARAMETER	SYMBOL	MAX	UNITS
PULSE FORWARD CURRENT	$I_P$	500	mA
STEADY CURRENT	$I_f$	350	mA
POWER DISSIPATION	$P_D$	1.5	W
OPERATING TEMP.	$T_{OPR}$	-20 TO +70	°C
STORAGE TEMP.	$T_{STG}$	-40 TO +85	°C

\*DUTY 1/10 PULSE WIDTH 10ms

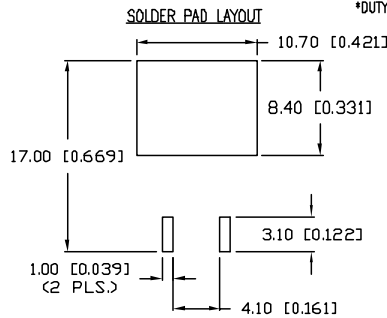
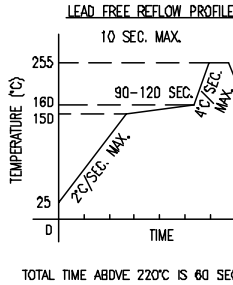

CAUTION: STATIC SENSITIVE DEVICE  
 FOLLOW PROPER E.S.D. HANDLING PROCEDURES  
 WHEN WORKING WITH THIS PART.

NOTES:

1. 50 PCS. IN EACH TUBE.



\*UNLESS OTHERWISE SPECIFIED TOLERANCES PER DECIMAL PRECISION ARE: X=±1 (±0.039), XX=±0.5 (±0.020), XXX=±0.25 (±0.010), XXXX=±0.127 (±0.005). LEAD SIZE=±0.06 (±0.002), LEAD LENGTH=±0.75 (±0.030). MIN.=+DECIMAL PRECISION -0.00 MAX.=+0.00 -DECIMAL PRECISION

UNCONTROLLED DOCUMENT

REV. A	PART NUMBER SML-LX1610UWC/A	<p><b>CONFIDENTIAL INFORMATION</b>          THE INFORMATION CONTAINED IN THIS DOCUMENT IS THE PROPERTY OF LUMEX INC. EXCEPT AS SPECIALLY AUTHORIZED IN WRITING BY LUMEX INC., THE HOLDER OF THIS DOCUMENT SHALL KEEP ALL INFORMATION CONTAINED HEREIN CONFIDENTIAL AND SHALL PROTECT SAME IN WHOLE OR IN PART FROM DISCLOSURE AND DISSEMINATION TO ALL THIRD PARTIES.</p> <p><b>RELIABILITY NOTE</b>          OUR MANY YEARS OF EXPERIENCE DATA ACCUMULATION INDICATE THAT SOLDER HEAT IS A MAJOR CAUSE OF EARLY AND FUTURE FAILURE. PLEASE PAY ATTENTION TO YOUR SOLDERING PROCESS.</p>	 290 E. HELEN ROAD PALATINE, IL 60067-6976 PHONE: +1.847.359.2790 US WEB: www.lumex.com TW WEB: www.lumex.com.tw
10.60 x 10mm HIGH POWER LED, ULTRA WHITE.		DRAWN BY: JC CHECKED BY: APPROVED BY:	DATE: 8.31.06 PAGE: 1 OF 1 SCALE: N/A