

Excellent Integrated System Limited

Stocking Distributor

Click to view price, real time Inventory, Delivery & Lifecycle Information:

[Pulse Electronics Corporation](#)

[PE-68017SNL](#)

For any questions, you can email us directly:

sales@integrated-circuit.com

PE-68017SNL

NOTICE: THE INFORMATION AND DESIGN CONTAINED HEREIN IS THE PROPERTY OF PULSE WHO RESERVES ALL RIGHTS THERETO.

NOTICE: THIS IS A RoHS COMPLIANT COMPONENT/PRODUCT. ALL ENGINEERING CHANGES MUST HAVE PRIOR APPROVAL BY THE DESIGN CENTER.

RoHS

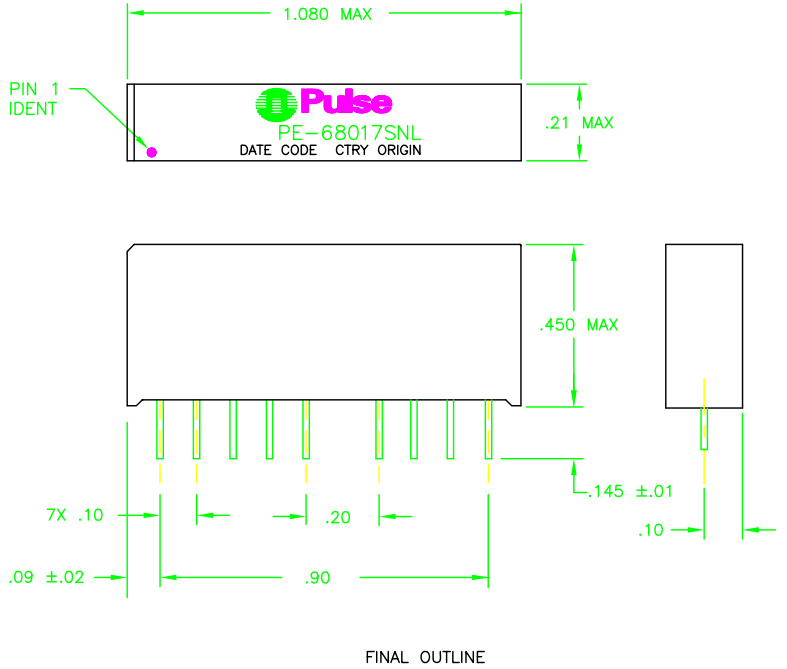
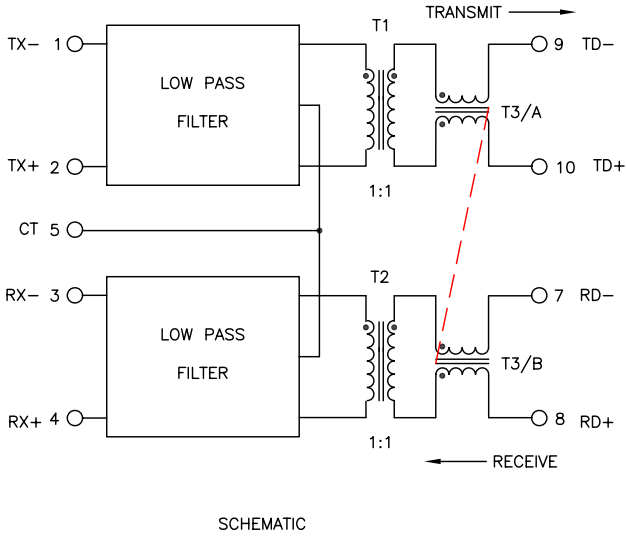

UNLESS OTHERWISE SPECIFIED, ALL DIMENSIONS ARE IN INCHES
TOLERANCES ARE:
DIMENSION ANGLES
.XX ±.01 ± 1°
.XXX ±.005
DO NOT SCALE DRAWING

| | | | |
|--------------|-------------------------|---------------|-------------|
| REV: 10 | DWG. NO. PE-68017SNL | DATE: B 01961 | SCALE: NONE |
| SHEET 7 OF 7 | CADD FILE PE-68017SNL-7 | | |

120072004

PE-68017SNL

NOTICE: THE INFORMATION AND DESIGN CONTAINED HEREIN IS THE PROPERTY OF PULSE WHO RESERVES ALL RIGHTS THERE TO.

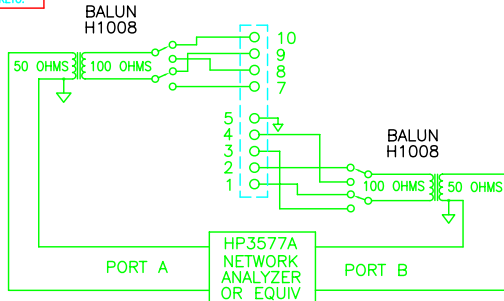

INSERTION LOSS TEST CIRCUIT
FIGURE 4

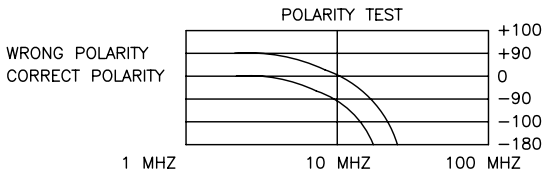
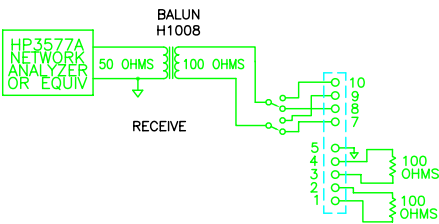

FIGURE 5



RETURN LOSS TEST CIRCUIT
FIGURE 6

TEST PROCEDURES:

UNLESS OTHERWISE SPECIFIED, TESTING IS PERFORMED AT 25°C ±5°C.

- HIPOT TEST: (100%) PRODUCTION LINE TO TEST AT 1650 VRMS 1 mA FOR 6 SECONDS, DVT, PILOT LINE AND QUALIFICATION SAMPLES TO TEST AT 1500 VRMS 1 mA FOR 1 MINUTE BETWEEN THE PINS (1 THRU 4) AND (7 THRU 10).
- CONNECTIVITY, OPEN AND SHORTS (100%): PER PQ: 3.064.000
- INSERTION LOSS: (100%) FIGURE 4 USE FIXTURE ITEM 24 CALIBRATE THE NETWORK ANALYZER IN THE S21 MODE BY SHORTING (1-9) AND SHORT (2-10) - DO A THRU CALIBRATION. MEASURE THE INSERTION LOSS BETWEEN 1 MHZ AND 100 MHZ. THE ATTENUATION SHALL BE WITHIN THE FOLLOWING LIMITS ON BOTH CHANNELS.

| FREQUENCY | ATTENUATION (S21) |
|-----------|-------------------|
| 1 MHZ | -1.0 dB MAX. |
| 10 MHZ | -1.0 dB MAX. |
| 30 MHZ | -30 dB MIN. |
| 50 MHZ | -25 dB MIN. |
| 100 MHZ | -27 dB MIN. |

| FREQUENCY | ATTENUATION (S21) |
|-----------|-------------------|
| 1 MHZ | -1.0 dB MAX. |
| 10 MHZ | -1.0 dB MAX. |
| 30 MHZ | -10 dB MIN. |
| 50 MHZ | -27 dB MIN. |
| 100 MHZ | -30 dB MIN. |

- POLARITY: (100%) FIGURE 5 USE FIXTURE ITEM 24 CALIBRATE THE SAME AS IN INSERTION LOSS. SET UP PHASE TEST PER FIGURE 4 ON THIS PAGE. PHASE SHALL BE NEGATIVE AND NEAR -45°. IF THE PHASE ANGLE IS POSITIVE AT 5 MHZ, THE UNIT IS REJECTED FOR POLARITY REVERSAL. SEE FIGURE 5.
- RETURN LOSS: (100%) FIGURE 6 USE FIXTURE ITEM 24 CALIBRATE THE NETWORK ANALYZER IN THE S11 MODE. DO ONE PORT FULL CAL WITH PINS 7-8. INSERT PART. MEASURE BOTH RECEIVE AND TRANSMIT TO BE WITHIN THE FOLLOWING LIMITS.

| FREQUENCY | TRANSMIT | RECEIVE |
|-----------|------------|------------|
| 5 MHZ | -21 dB MIN | -20 dB MIN |
| 7.5 MHZ | -21 dB MIN | -19 dB MIN |
| 10 MHZ | -21 dB MIN | -20 dB MIN |

UNLESS OTHERWISE SPECIFIED, ALL DIMENSIONS ARE IN INCHES
DIMENSIONS ANGLES
.XX ±.01 ±.1°
.XXX ±.005
DO NOT SCALE DRAWING

REV: 10
DWS. NO. PE-68017SNL
SCALE NONE
CADD FILE
SHEET 5 OF 7

PE-68017SNL

NOTICE: THE INFORMATION AND DESIGN CONTAINED HEREIN IS THE PROPERTY OF PULSE WHO RESERVES ALL RIGHTS THERETO.

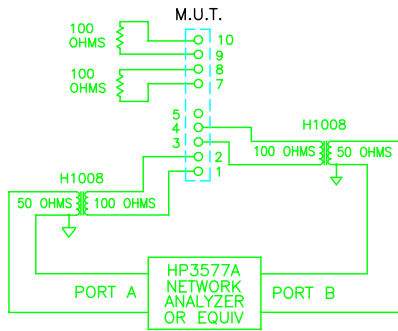

CROSSTALK
FIGURE 7

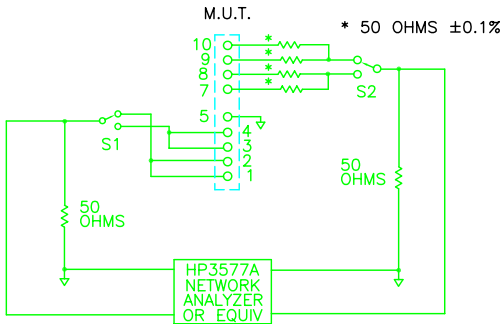

COMMON MODE REJECTION
FIGURE 8

TEST PROCEDURES: (CONTINUED)

6. CROSSTALK: (SAMPLE TEST) FIGURE 7 USE FIXTURE ITEM 22 CALIBRATE THE NETWORK ANALYZER IN THE S21 MODE BY SHORTING (1-3) AND SHORTING (2-4). DO A THRU CALIBRATION. MEASURE THE CROSSTALK BETWEEN THE TWO CHANNELS OVER THE RANGE OF 5 MHZ TO 50 MHZ. THE CROSSTALK ATTENUATION SHALL BE WITHIN THE FOLLOWING LIMITS:

| FREQUENCY | ATTENUATION (S21) |
|-----------|-------------------|
| 5 MHZ | -45 dB MIN. |
| 10 MHZ | -40 dB MIN. |
| 30 MHZ | -30 dB MIN. |
| 50 MHZ | -20 dB MIN. |

7. COMMON MODE REJECTION: (SAMPLE TEST) FIGURE 8 USE FIXTURE ITEM 23 CALIBRATE THE NETWORK ANALYZER IN THE S21 MODE BY CONNECTING A 50 OHM COAXIAL CABLE BETWEEN THE OUTPUT AND INPUT PORTS OF THE S PARAMETERS TEST SET AND PERFORM A THRU CALIBRATION. REMOVE THE SHORT AND CONNECT THE TEST UNIT PER FIGURE 16. MEASURE THE COMMON MODE REJECTION AT THE FREQUENCIES BELOW. THE COMMON MODE SHALL BE WITHIN THE LIMITS ON BOTH CHANNELS.

| TRANSMIT (1-2) | | RECEIVE (3-4) | |
|----------------|-------------------|---------------|-------------------|
| FREQUENCY | ATTENUATION (S21) | FREQUENCY | ATTENUATION (S21) |
| 5 MHZ | -35 dB MIN. | 5 MHZ | -35 dB MIN. |
| 10 MHZ | -31 dB MIN. | 10 MHZ | -30 dB MIN. |
| 30 MHZ | -55 dB MIN. | 30 MHZ | -50 dB MIN. |
| 50 MHZ | -55 dB MIN. | 45 MHZ | -45 dB MIN. |
| 100 MHZ | -45 dB MIN. | 100 MHZ | -45 dB MIN. |
| 200 MHZ | -40 dB MIN. | 200 MHZ | -40 dB MIN. |

UNLESS OTHERWISE SPECIFIED, ALL DIMENSIONS ARE IN INCHES
DIMENSIONS: .XX ±.01 ANGLES: ± 1°
DO NOT SCALE DRAWING

REV: 10
DWS. NO. PE-68017SNL
SCALE NONE
SHEET 6 OF 7