

## **Excellent Integrated System Limited**

Stocking Distributor

Click to view price, real time Inventory, Delivery & Lifecycle Information:

[Infineon Technologies](#)

[BFR750L3RHE6327XTSA1](#)

For any questions, you can email us directly:

[sales@integrated-circuit.com](mailto:sales@integrated-circuit.com)



## BFR750L3RH

### NPN Silicon Germanium RF Transistor\*

- High gain ultra low noise RF transistor
- Provides outstanding performance for a wide range of wireless applications up to 10 GHz
- Ideal for WLAN and all 5-6 GHz applications
- High  $OIP_3$  and  $P_{-1dB}$  for driver stages
- High maximum stable and available gain  
 $G_{ms} = 21$  dB at 1.8 GHz,  $G_{ma} = 11.5$  dB at 6 GHz
- 150 GHz  $f_T$ -Silicon Germanium technology
- Extremely small and flat leadless package, reduced height 0.32 mm max.
- Pb-free (RoHS compliant) package<sup>1)</sup>
- Qualified according AEC Q101

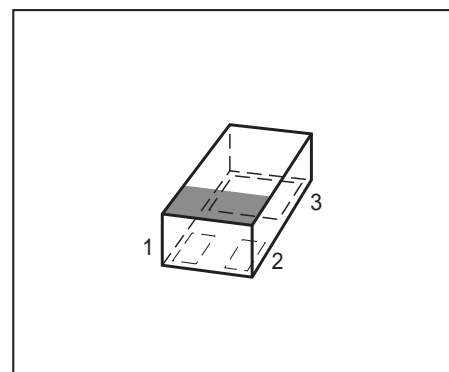

\* Short term description



**ESD (Electrostatic discharge) sensitive device, observe handling precaution!**

Type	Marking	Pin Configuration			Package
BFR750L3RH	R8	1=B	2=C	3=E	TSLP-3-9

<sup>1</sup>Pb-containing package may be available upon special request



## BFR750L3RH

### Maximum Ratings

Parameter	Symbol	Value	Unit
Collector-emitter voltage $T_A > 0^\circ\text{C}$ $T_A \leq 0^\circ\text{C}$	$V_{\text{CEO}}$	4 3.5	V
Collector-emitter voltage	$V_{\text{CES}}$	13	
Collector-base voltage	$V_{\text{CBO}}$	13	
Emitter-base voltage	$V_{\text{EBO}}$	1.2	
Collector current	$I_{\text{C}}$	90	mA
Base current	$I_{\text{B}}$	9	
Total power dissipation <sup>1)</sup> $T_{\text{S}} \leq 96^\circ\text{C}$	$P_{\text{tot}}$	360	mW
Junction temperature	$T_{\text{j}}$	150	$^\circ\text{C}$
Ambient temperature	$T_{\text{A}}$	-65 ... 150	
Storage temperature	$T_{\text{stg}}$	-65 ... 150	

### Thermal Resistance

Parameter	Symbol	Value	Unit
Junction - soldering point <sup>2)</sup>	$R_{\text{thJS}}$	$\leq 150$	K/W

### Electrical Characteristics at $T_A = 25^\circ\text{C}$ , unless otherwise specified

Parameter	Symbol	Values			Unit
		min.	typ.	max.	

### DC Characteristics

Collector-emitter breakdown voltage $I_{\text{C}} = 3 \text{ mA}, I_{\text{B}} = 0$	$V_{(\text{BR})\text{CEO}}$	4	4.7	-	V
Collector-emitter cutoff current $V_{\text{CE}} = 13 \text{ V}, V_{\text{BE}} = 0$	$I_{\text{CES}}$	-	-	100	$\mu\text{A}$
Collector-base cutoff current $V_{\text{CB}} = 5 \text{ V}, I_{\text{E}} = 0$	$I_{\text{CBO}}$	-	-	100	nA
Emitter-base cutoff current $V_{\text{EB}} = 0.5 \text{ V}, I_{\text{C}} = 0$	$I_{\text{EBO}}$	-	-	10	$\mu\text{A}$
DC current gain $I_{\text{C}} = 60 \text{ mA}, V_{\text{CE}} = 3 \text{ V}$ , pulse measured	$h_{\text{FE}}$	160	250	400	-

<sup>1</sup>  $T_{\text{S}}$  is measured on the collector lead at the soldering point to the pcb

<sup>2</sup> For calculation of  $R_{\text{thJA}}$  please refer to Application Note Thermal Resistance

$R_{\text{thJS}}$  demanded by  $P_{\text{tot}}$  and  $T_{\text{S}}$ , to be fulfilled by design



## BFR750L3RH

Electrical Characteristics at  $T_A = 25^\circ\text{C}$ , unless otherwise specified

Parameter	Symbol	Values			Unit
		min.	typ.	max.	
<b>AC Characteristics</b> (verified by random sampling)					
Transition frequency $I_C = 60\text{ mA}$ , $V_{CE} = 3\text{ V}$ , $f = 2\text{ GHz}$	$f_T$	-	37	-	GHz
Collector-base capacitance $V_{CB} = 3\text{ V}$ , $f = 1\text{ MHz}$ , emitter grounded	$C_{cb}$	-	0.24	0.42	pF
Collector emitter capacitance $V_{CE} = 3\text{ V}$ , $f = 1\text{ MHz}$ , base grounded	$C_{ce}$	-	0.31	-	
Emitter-base capacitance $V_{EB} = 0.5\text{ V}$ , $f = 1\text{ MHz}$ , collector grounded	$C_{eb}$	-	0.97	-	
Noise figure $I_C = 25\text{ mA}$ , $V_{CE} = 3\text{ V}$ , $f = 1.8\text{ GHz}$ , $Z_S = Z_{Sopt}$ $I_C = 25\text{ mA}$ , $V_{CE} = 3\text{ V}$ , $f = 6\text{ GHz}$ , $Z_S = Z_{Sopt}$	$F$	-	0.6 1.1	-	dB
Power gain, maximum stable <sup>1)</sup> $I_C = 60\text{ mA}$ , $V_{CE} = 3\text{ V}$ , $Z_S = Z_{Sopt}$ , $Z_L = Z_{Lopt}$ , $f = 1.8\text{ GHz}$	$G_{ms}$	-	21	-	dB
Power gain, maximum available <sup>1)</sup> $I_C = 60\text{ mA}$ , $V_{CE} = 3\text{ V}$ , $Z_S = Z_{Sopt}$ , $Z_L = Z_{Lopt}$ , $f = 6\text{ GHz}$	$G_{ma}$	-	11.5	-	dB
Transducer gain $I_C = 60\text{ mA}$ , $V_{CE} = 3\text{ V}$ , $Z_S = Z_L = 50\ \Omega$ , $f = 1.8\text{ GHz}$ $I_C = 60\text{ mA}$ , $V_{CE} = 3\text{ V}$ , $Z_S = Z_L = 50\ \Omega$ , $f = 6\text{ GHz}$	$ S_{21e} ^2$	-	18 8	-	dB
Third order intercept point at output <sup>2)</sup> $V_{CE} = 3\text{ V}$ , $I_C = 60\text{ mA}$ , $f = 1.8\text{ GHz}$ , $Z_S = Z_L = 50\ \Omega$	$IP_3$	-	29.5	-	dBm
1dB Compression point at output $I_C = 60\text{ mA}$ , $V_{CE} = 3\text{ V}$ , $Z_S = Z_L = 50\ \Omega$ , $f = 1.8\text{ GHz}$	$P_{-1dB}$	-	16.5	-	

<sup>1</sup> $G_{ma} = |S_{21e} / S_{12e}| (k - (k^2 - 1)^{1/2})$ ,  $G_{ms} = |S_{21e} / S_{12e}|$

<sup>2</sup>IP3 value depends on termination of all intermodulation frequency components.

Termination used for this measurement is 50Ω from 0.1 MHz to 6 GHz



**BFR750L3RH**

**SPICE Parameter (Gummel-Poon Model, Berkley-SPICE 2G.6 Syntax):**

**Transistor Chip Data:**

IS =	2.66 e-12	mA	BF =	753	-	NF =	1.015	-
VAF =	95	V	IKF =	292	mA	ISE =	1.54 e-11	mA
NE =	1.8	-	BR =	76	-	NR =	1	-
VAR =	1.33	V	IKR =	1.33	mA	ISC =	1 e-27	mA
NC =	2	-	RB =	1	Ω	IRB =	1 e15	A
RBM =	0.9	Ω	RE =	20	mΩ	RC =	0.9	Ω
CJE =	0.475	pF	VJE =	0.69	V	MJE =	0.085	-
TF =	0.0021	ns	XTF =	3	-	VTF =	2.1	V
ITF =	2540	mA	PTF =	0.5	-	CJC =	0.173	pF
VJC =	0.45	V	MJC =	0.31	-	XCJC =	0.01	-
TR =	1.2	ns	CJS =	0.325	pF	VJS =	0.65	V
MJS =	0.25	-	XTB =	-2.2	-	EG =	1.11	-
XTI =	0.436	-	FC =	0.5	-	TNOM	25	°C
AF =	1	-	KF =	0	-			

All parameters are ready to use, no scaling is necessary.

**Package Equivalent Circuit:**

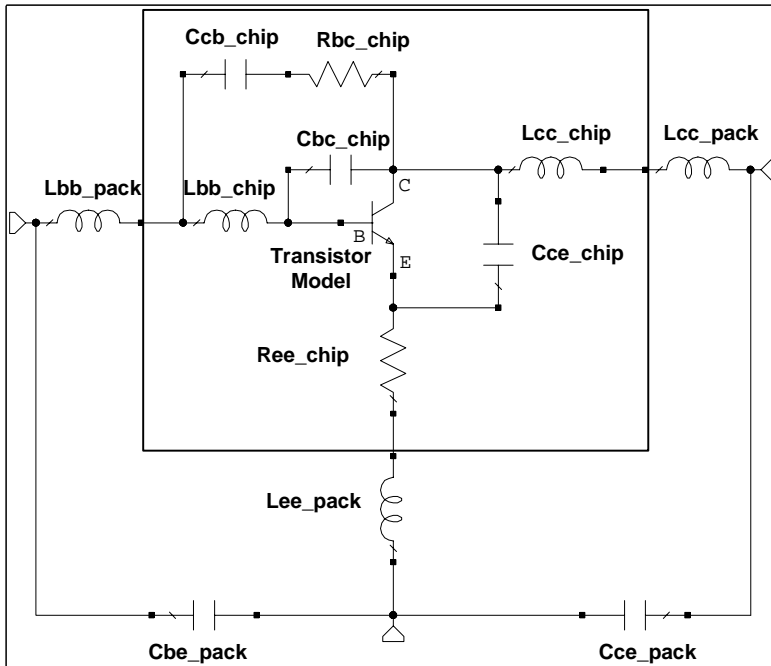

$L_{bb\_chip}$	=	0.212	nA
$L_{cc\_chip}$	=	0.07472	nH
$L_{bb\_pack}$	=	0.0184	nH
$L_{cc\_pack}$	=	0.277	nH
$L_{ee\_pack}$	=	0.239	nH
$C_{bc\_chip}$	=	0.015	pF
$C_{cb\_chip}$	=	0.013	pF
$C_{ce\_chip}$	=	0.282	pF
$C_{be\_pack}$	=	0.064	pF
$C_{ce\_pack}$	=	0.0492	pF
$R_{bc\_chip}$	=	7	Ω
$R_{ee\_chip}$	=	0.566	Ω

Valid up to 6GHz

For examples and ready to use parameters please contact your local Infineon Technologies distributor or sales office to obtain a Infineon Technologies CD-ROM or see Internet: <http://www.infineon.com>



**BFR750L3RH**

**Total power dissipation  $P_{tot} = f(T_S)$**

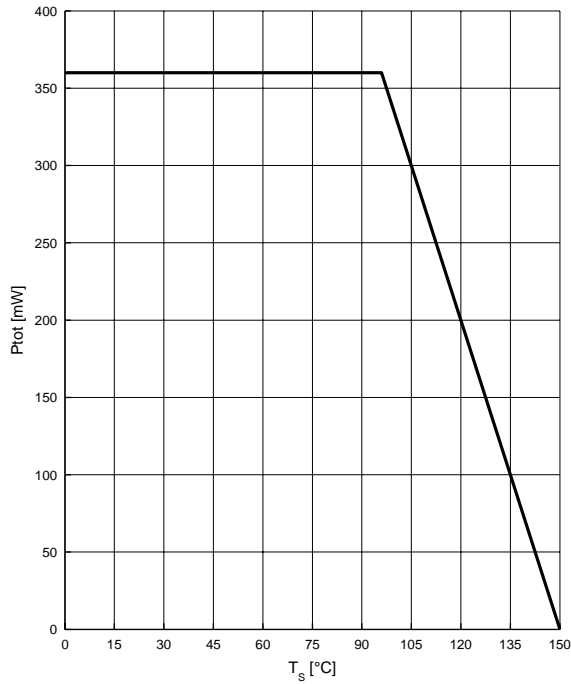

**Permissible Puls Load  $R_{thJS} = f(t_p)$**

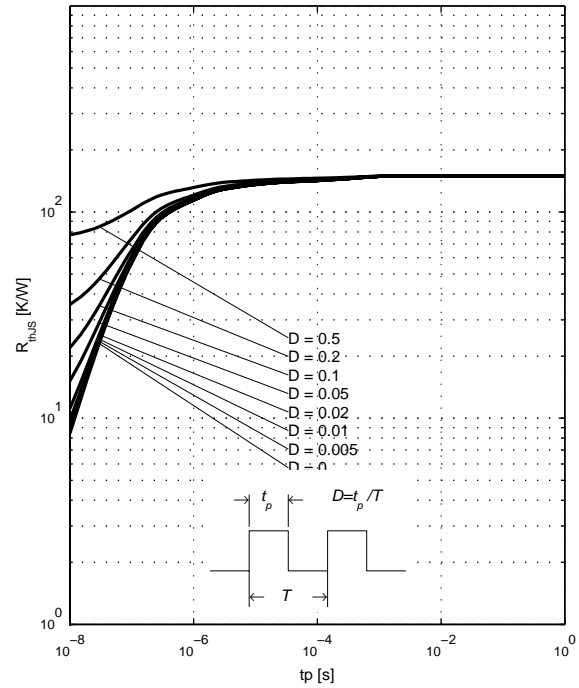

**Permissible Pulse Load**

$P_{totmax} / P_{totDC} = f(t_p)$

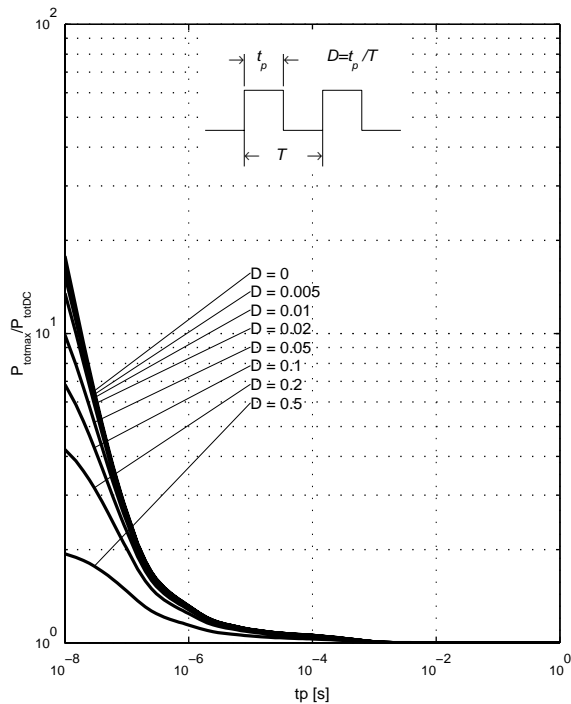

**Collector-base capacitance  $C_{cb} = f(V_{CB})$**

$f = 1 \text{ MHz}$

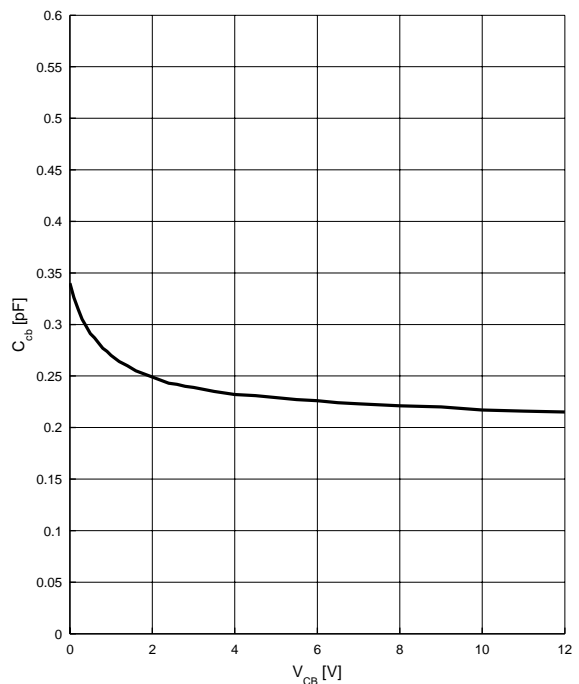



**BFR750L3RH**

**Transition frequency  $f_T = f(I_C)$**

$V_{CE} = \text{parameter}, f = 1 \text{ GHz}$

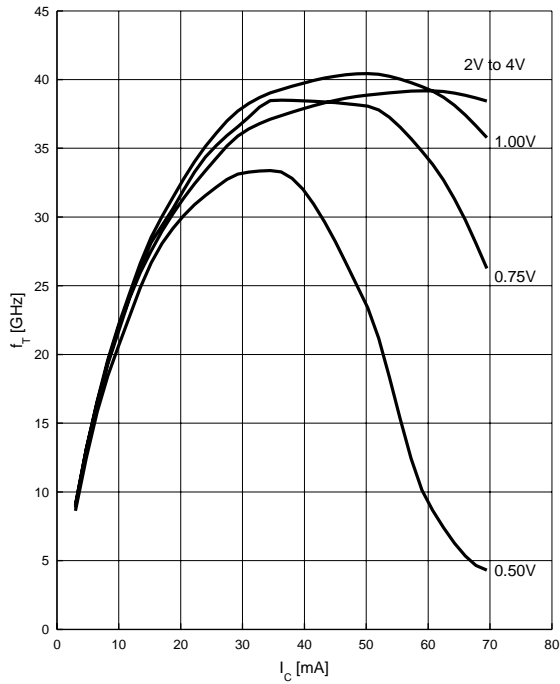

**Power gain  $G_{ma}, G_{ms} = f(f)$**

$V_{CE} = 3 \text{ V}, I_C = 60 \text{ mA}$

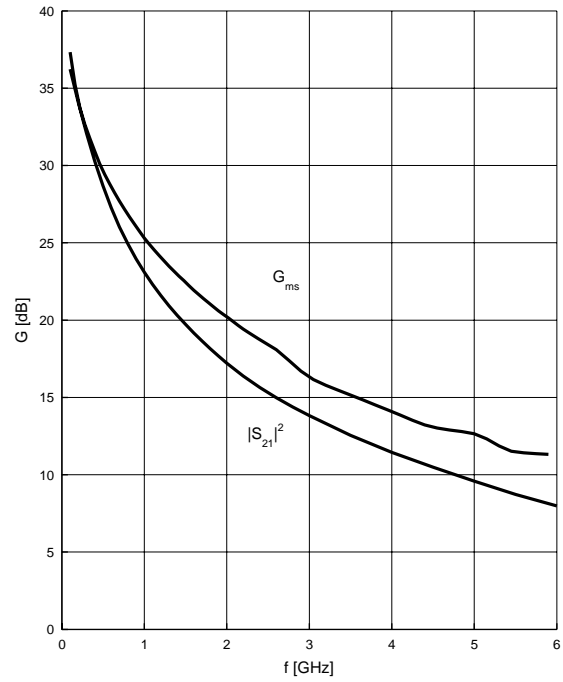

**Power gain  $G_{ma}, G_{ms} = f(I_C)$**

$V_{CE} = 3 \text{ V}$

$f = \text{parameter}$

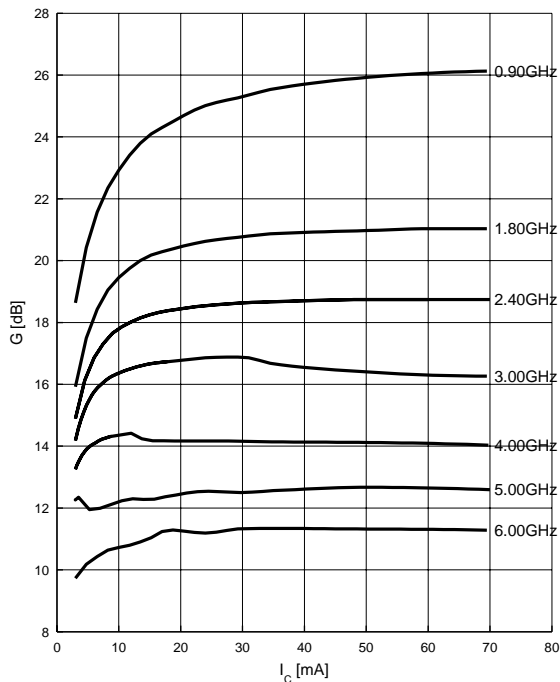

**Power gain  $G_{ma}, G_{ms} = f(V_{CE})$**

$I_C = 60 \text{ mA}$

$f = \text{parameter}$

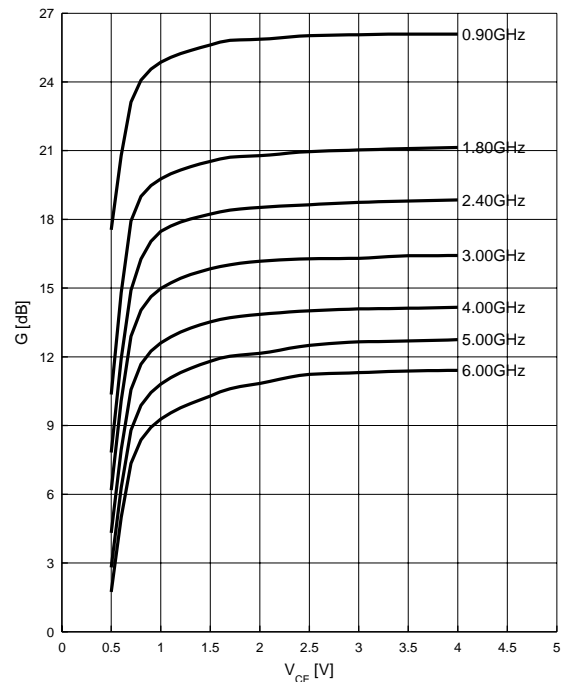



**Package TSLP-3-9**

**BFR750L3RH**

**Package Outline**

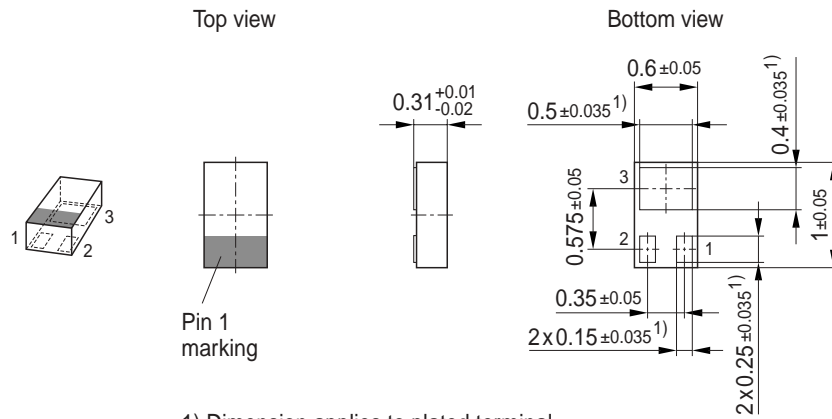

1) Dimension applies to plated terminal

**Foot Print**

For board assembly information please refer to Infineon website "Packages"

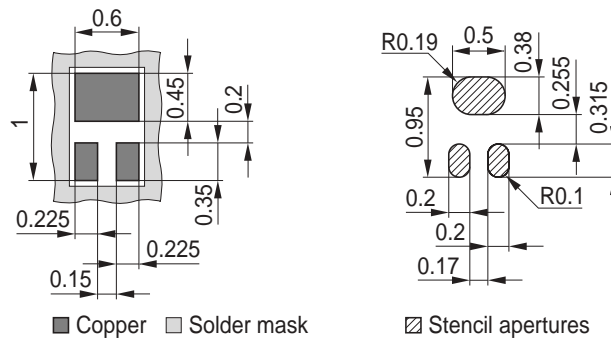

**Marking Layout (Example)**

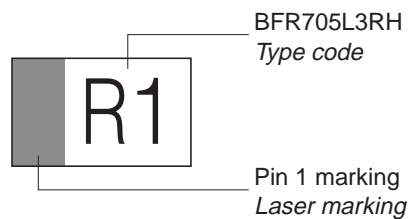

**Standard Packing**

Reel ø180 mm = 15.000 Pieces/Reel

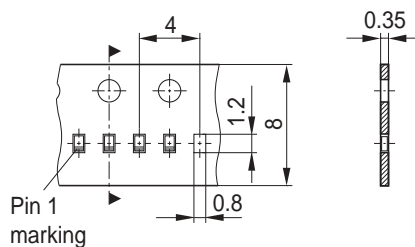





**BFR750L3RH**

---

Edition 2006-02-01

Published by

Infineon Technologies AG

81726 München, Germany

© Infineon Technologies AG 2007.

All Rights Reserved.

### **Attention please!**

The information given in this dokument shall in no event be regarded as a guarantee of conditions or characteristics (“Beschaffheitsgarantie”). With respect to any examples or hints given herein, any typical values stated herein and/or any information regarding the application of the device, Infineon Technologies hereby disclaims any and all warranties and liabilities of any kind, including without limitation warranties of non-infringement of intellectual property rights of any third party.

### **Information**

For further information on technology, delivery terms and conditions and prices please contact your nearest Infineon Technologies Office ([www.infineon.com](http://www.infineon.com)).

### **Warnings**

Due to technical requirements components may contain dangerous substances. For information on the types in question please contact your nearest Infineon Technologies Office.

Infineon Technologies Components may only be used in life-support devices or systems with the express written approval of Infineon Technologies, if a failure of such components can reasonably be expected to cause the failure of that life-support device or system, or to affect the safety or effectiveness of that device or system.

Life support devices or systems are intended to be implanted in the human body, or to support and/or maintain and sustain and/or protect human life. If they fail, it is reasonable to assume that the health of the user or other persons may be endangered.