



Excellent Integrated System Limited

Stocking Distributor

Click to view price, real time Inventory, Delivery & Lifecycle Information:

[EDAC Inc.](#)
[516-294-571](#)

For any questions, you can email us directly:
sales@integrated-circuit.com

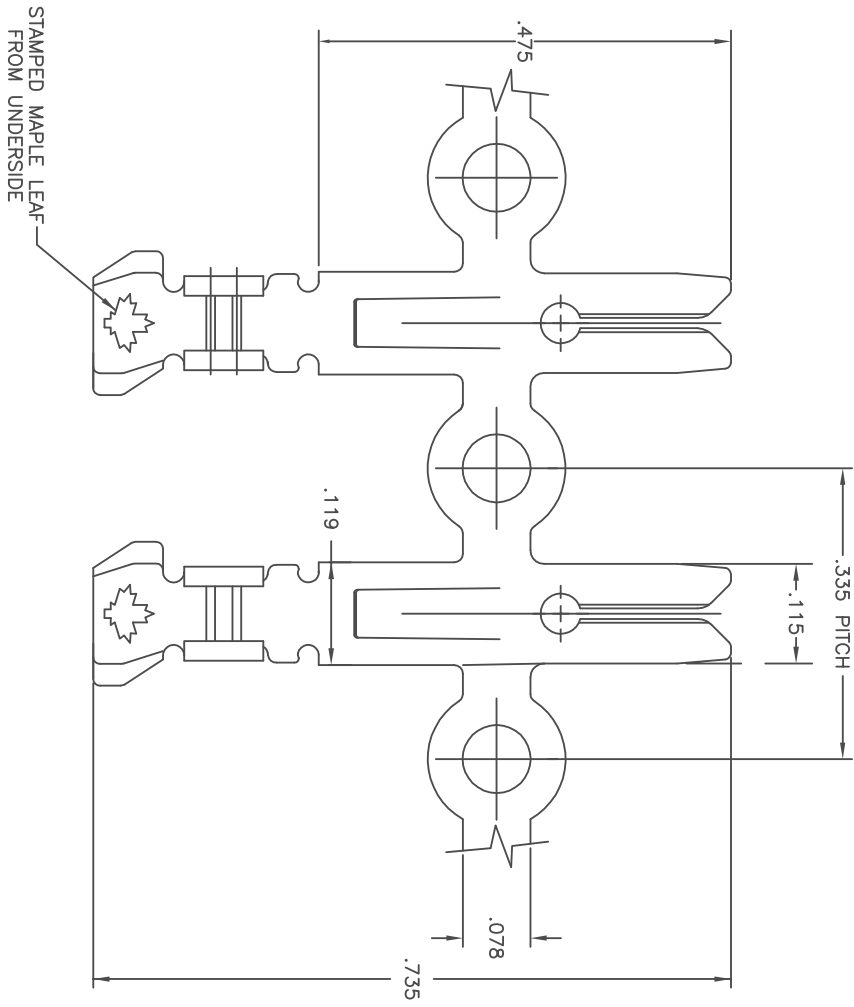

NOTES:

1) MATERIAL: $\pm .0005$.0225 THICK PHOSPHOR BRONZE, GRADE A, 95000-105000 PSI TENSILE.

THIS IS A CAD GENERATED DRAWING
 DO NOT MAKE MANUAL REVISIONS TO MASTER.



ISSUE NUMBER
 ORIGINAL ①

516 CRIMP CONTACT DETAIL FOR 516-290-571 AND 516-294-571 REELS		ACAD REFERENCE NO. 51629001	
EDAC INC TORONTO, ONTARIO CANADA		DRAWN: F.BRIONES DATE: OCT.24/07	
YOUR CONNECTION TO QUALITY & SERVICE		PART NUMBER 516-290-571, 516-294-571	
THESE DRAWINGS AND SPECIFICATIONS ARE THE PROPERTY OF EDAC INC. AND SHALL NOT BE REPRODUCED OR COPIED OR USED AS THE BASIS FOR THE MANUFACTURE OR SALE OF APPARATUS WITHOUT WRITTEN PERMISSION.		DRAWING NUMBER 516-290-571, 516-294-571	
		ISSUE 1	

THIS IS A C.A.D. GENERATED DRAWING
 DO NOT MAKE MANUAL REVISIONS TO MASTER.



ISSUE NUMBER
ORIGINAL ①

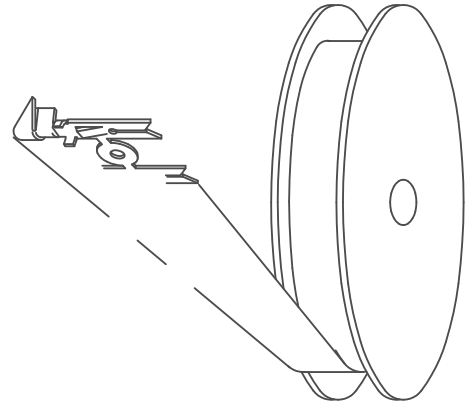
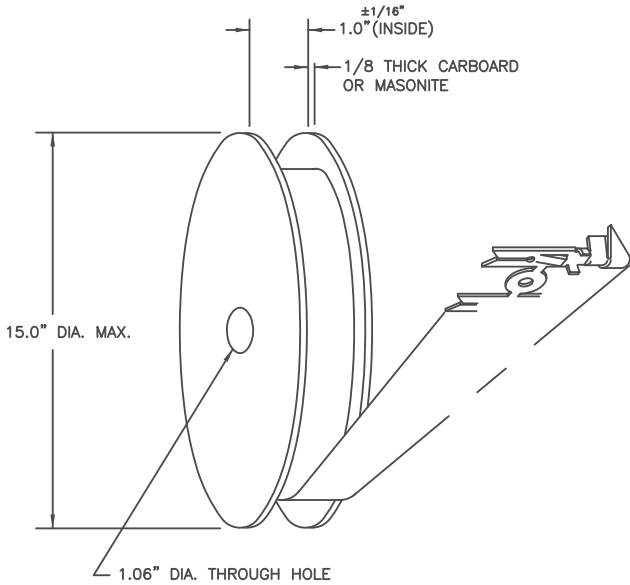

PART NUMBER 516-290-571

PART NUMBER 516-294-571

NOTES:

- 1) EACH REEL SHALL CONTAIN A CONTINUOUS STRIP OF 1800 +/-20 CONTACTS. NO BREAKS OR JOININGS PERMITTED IN CONTACT CARRIER. MAXIMUM 2 CONTACTS PER REEL MAY BE OMITTED (CUT AWAY FOR TESTING PURPOSES).
- 2) CONTACTS TO BE WOUND ONTO REEL IN ACCORDANCE WITH ALL VIEWS.
- 3) DO NOT INTERLEAVE PAPER BETWEEN CONTACTS.

516 SERIES CRIMP CONTACTS ON REEL
 ORIENTATION-READY FOR CUSTOMER USE

ACAD REFERENCE NO. 51629001

DRAWN: F.BRIONES

DATE: JULY 4/97

CHECKED:

DATE:

SCALE:

SHEET 1 OF 1

DRAWING NUMBER

516-290-013

ISSUE

1



EDAC INC
 TORONTO, ONTARIO
 CANADA

YOUR CONNECTION TO QUALITY & SERVICE

THESE DRAWINGS AND SPECIFICATIONS ARE THE PROPERTY OF EDAC INC., AND SHALL NOT BE REPRODUCED, OR COPIED OR USED AS THE BASIS FOR THE MANUFACTURE OR SALE OF APPARATUS WITHOUT WRITTEN PERMISSION.