

Excellent Integrated System Limited

Stocking Distributor

Click to view price, real time Inventory, Delivery & Lifecycle Information:

[ON Semiconductor](#)
[MC74LVXC3245DT](#)

For any questions, you can email us directly:

sales@integrated-circuit.com

MC74LVXC3245

Configurable Dual Supply Octal Transceiver

with 3-State Outputs for 3 V Systems

The 74LVXC3245 is a 24-pin dual-supply, octal configurable voltage interface transceiver especially well suited for PCMCIA and other real time configurable I/O applications. The V_{CCA} pin accepts a 3.0 V supply level; the A port is a dedicated 3.0 V port. The V_{CCB} pin accepts a 3.0 V-to-5.0 V supply level. The B port is configured to track the V_{CCB} supply level. A 5.0 V level on the V_{CCB} pin will configure the I/O pins at a 5.0 V level and a 3.0 V V_{CCB} will configure the I/O pins at a 3.0 V level. The A port interfaces with a 3.0 V host system and the B port to the card slots. This device will allow the V_{CCB} voltage source pin and I/O pins on the B port to float when \overline{OE} is High. This feature is necessary to buffer data to and from a PCMCIA socket that permits PCMCIA cards to be inserted and removed during normal operation. The Transmit/Receive (T/\overline{R}) input determines the direction of data flow. Transmit (active-High) enables data from the A port to B port. Receive (active-Low) enables data from the B port to the A port.

Features

- Bidirectional Interface Between 3.0 V and 3.0 V/5.0 V Buses
- Control Inputs Compatible with TTL Level
- Outputs Source/Sink Up to 24 mA
- Guaranteed Simultaneous Switching Noise Level and Dynamic Threshold Performance
- Available in SOIC and TSSOP Packages
- Flexible V_{CCB} Operating Range
- Allows B Port and V_{CCB} to Float Simultaneously When \overline{OE} is High
- Functionally Compatible With the 74 Series 245
- Pb-Free Packages are Available*



ON Semiconductor®

<http://onsemi.com>

MARKING DIAGRAMS

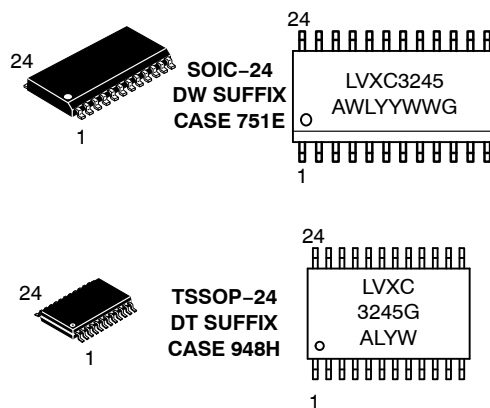

A = Assembly Location
 WL, L = Wafer Lot
 YY, Y = Year
 WW, W = Work Week
 G = Pb-Free Package

ORDERING INFORMATION

See detailed ordering and shipping information in the package dimensions section on page 5 of this data sheet.

*For additional information on our Pb-Free strategy and soldering details, please download the ON Semiconductor Soldering and Mounting Techniques Reference Manual, SOLDERRM/D.

MC74LVXC3245

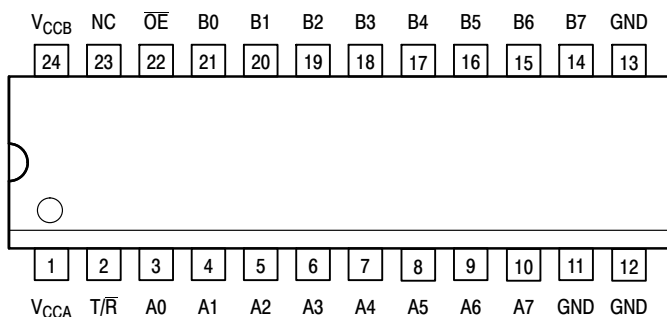

Figure 1. 24-Lead Pinout (Top View)

PIN NAMES

Pins	Function
OE	Output Enable Input
T/R	Transmit/Receive Input
A0-A7	Side A 3-State Inputs or 3-State Outputs
B0-B7	Side B 3-State Inputs or 3-State Outputs

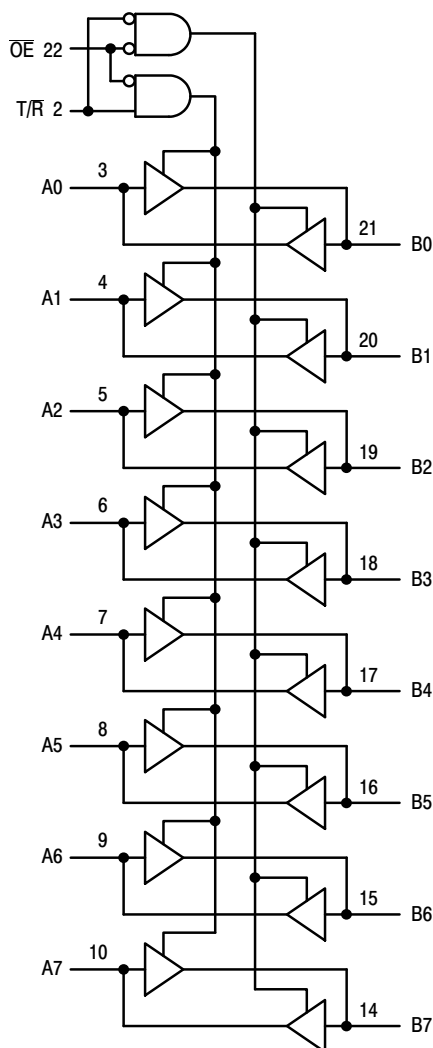

Figure 2. Logic Diagram

INPUTS		OPERATING MODE Non-Inverting
OE	T/R	
L	L	B Data to A Bus
L	H	A Data to B Bus
H	X	Z

H = High Voltage Level; L = Low Voltage Level; Z = High Impedance State; X = High or Low Voltage Level and Transitions are Acceptable; for I_{CC} reasons, Do Not Float Inputs

MC74LVXC3245

MAXIMUM RATINGS

Symbol	Parameter	Value	Condition	Unit
V_{CCA}, V_{CCB}	DC Supply Voltage	-0.5 to +7.0		V
V_I	DC Input Voltage $\overline{OE}, T/\overline{R}$	-0.5 to $V_{CCA} + 0.5$		V
$V_{I/O}$	DC Input/Output Voltage	An	-0.5 to $V_{CCA} + 0.5$	V
		Bn	-0.5 to $V_{CCB} + 0.5$	V
I_{IK}	DC Input Diode Current $\overline{OE}, T/\overline{R}$	± 20	$V_I < GND$	mA
I_{OK}	DC Output Diode Current	± 50	$V_O < GND; V_O > V_{CC}$	mA
I_O	DC Output Source/Sink Current	± 50		mA
I_{CC}, I_{GND}	DC Supply Current Per Output Pin Maximum Current	± 50 ± 200		mA
T_{STG}	Storage Temperature Range	-65 to +150		$^{\circ}C$
	DC Latchup Source/Sink Current	± 300		mA

Stresses exceeding Maximum Ratings may damage the device. Maximum Ratings are stress ratings only. Functional operation above the Recommended Operating Conditions is not implied. Extended exposure to stresses above the Recommended Operating Conditions may affect device reliability.

RECOMMENDED OPERATING CONDITIONS

Symbol	Parameter	Min	Max	Unit	
V_{CCA}, V_{CCB}	Supply Voltage ($V_{CCA} \leq V_{CCB}$)	V_{CCA}	2.3	3.6	V
		V_{CCB}	3.0	5.5	
V_I	Input Voltage $\overline{OE}, T/\overline{R}$	0	V_{CCA}	V	
$V_{I/O}$	Input/Output Voltage	An	0	V_{CCA}	V
		Bn	0	V_{CCB}	
T_A	Operating Free-Air Temperature	-40	+85	$^{\circ}C$	
$\Delta t/\Delta V$	Minimum Input Edge Rate V_{IN} from 30% to 70% of V_{CC} ; V_{CC} at 3.0 V, 4.5 V, 5.5 V	0	8	ns/V	

DC ELECTRICAL CHARACTERISTICS

Symbol	Parameter	Condition	V_{CCA}	V_{CCB}	$T_A = 25^{\circ}C$		$T_A = -40 \text{ to } +85^{\circ}C$		Unit
					Typ	Guaranteed Limits			
V_{IHA}	Minimum HIGH Level Input Voltage	An $V_{OUT} \leq 0.1 V$ or $\geq V_{CC} - 0.1 V$	2.3	3.0		2.0	2.0	V	
			3.0	3.6		2.0	2.0		
			3.6	5.5		2.0	2.0		
V_{IHB}		Bn	2.3	3.0		2.00	2.00	V	
			3.0	3.6		2.00	2.00		
			3.6	5.5		3.85	3.85		
V_{ILA}	Maximum LOW Level Input Voltage	An $V_{OUT} \leq 0.1 V$ or $\geq V_{CC} - 0.1 V$	2.3	3.0		0.8	0.8	V	
			3.0	3.6		0.8	0.8		
			3.6	5.5		0.8	0.8		
V_{ILB}		Bn	2.3	3.0		0.80	0.80	V	
			3.0	3.6		0.80	0.80		
			3.6	5.5		1.65	1.65		
V_{OHA}	Minimum HIGH Level Output Voltage	$I_{OUT} = -100 \mu A$ $I_{OH} = -12 mA$ $I_{OH} = -24 mA$ $I_{OH} = -12 mA$ $I_{OH} = -24 mA$	3.0	3.0	2.99	2.90	2.90	V	
			3.0	3.0	2.85	2.56	2.46		
			3.0	3.0	2.65	2.35	2.25		
			2.3	3.0	2.50	2.30	2.20		
			2.3	4.5	2.30	2.10	2.00		
V_{OHB}		$I_{OUT} = -100 \mu A$ $I_{OH} = -12 mA$ $I_{OH} = -24 mA$ $I_{OH} = -24 mA$	3.0	3.0	2.99	2.90	2.90	V	
			3.0	3.0	2.85	2.56	2.46		
			3.0	3.0	2.65	2.35	2.25		
			3.0	3.0	2.65	2.35	2.25		
			3.0	4.5	4.25	3.86	3.76		

MC74LVXC3245

DC ELECTRICAL CHARACTERISTICS

Symbol	Parameter	Condition	V _{CCA}	V _{CCB}	T _A = 25°C		T _A = -40 to +85°C		Unit	
					Typ	Guaranteed Limits				
V _{OLA}	Maximum LOW Level Output Voltage	I _{OUT} = 100 μA	3.0	3.0	0.002	0.10	0.10		V	
		I _{OL} = 24 mA	3.0	3.0	0.21	0.36	0.44			
		I _{OL} = 12 mA	2.7	3.0	0.11	0.36	0.44			
		I _{OL} = 24 mA	2.7	4.5	0.22	0.42	0.50			
V _{OLB}		I _{OUT} = 100 μA	3.0	3.0	0.002	0.10	0.10		V	
		I _{OL} = 24 mA	3.0	3.0	0.21	0.36	0.44			
		I _{OL} = 24 mA	3.0	4.5	0.18	0.36	0.44			
I _{IN}	Max Input Leakage Current	\overline{OE} , T/R	V _I = V _{CCA} , GND	3.6 3.6	3.6 5.5		±0.1 ±0.1	±1.0 ±1.0	μA	
I _{OZA}	Max 3-State Output Leakage	An	V _I = V _{IH} , V _{IL} \overline{OE} = V _{CCA} V _O = V _{CCA} , GND	3.6 3.6	3.6 5.5		±0.5 ±0.5	±5.0 ±5.0	μA	
I _{OZB}	Max 3-State Output Leakage	Bn	V _I = V _{IH} , V _{IL} \overline{OE} = V _{CCA} V _O = V _{CCB} , GND	3.6 3.6	3.6 5.5		±0.5 ±0.5	±5.0 ±5.0	μA	
ΔI _{CC}	Maximum I _{CC} /Input	Bn	V _I = V _{CCB} -2.1 V	3.6	5.5	1.0	1.35	1.5		mA
		All In-puts	V _I = V _{CC} -0.6 V	3.6	3.6		0.35	0.5		mA
I _{CCA1}	Quiescent V _{CCA} Supply Current as B Port Floats		An = V _{CCA} or GND Bn = Open, \overline{OE} = V _{CCA} , T/R = V _{CCA} , V _{CCB} = Open	3.6	Open		5	50		μA
I _{CCA2}	Quiescent V _{CCA} Supply Current		An = V _{CCA} or GND Bn = V _{CCB} or GND, \overline{OE} = GND, T/R = GND	3.6 3.6	3.6 5.5		5 5	50 50		μA
I _{CCB}	Quiescent V _{CCB} Supply Current		An = V _{CCA} or GND Bn = V _{CCB} or GND, \overline{OE} = GND, T/R = V _{CCA}	3.6 3.6	3.6 5.5		5 8	50 80		μA
V _{OLPA}	Quiet Output Max Dynamic V _{OL}		Notes 1, 2	3.3 3.3	3.3 5.0		0.8 0.8			V
V _{OLPB}			Notes 1, 2	3.3 3.3	3.3 5.0		0.8 1.5			V
V _{OLVA}	Quiet Output Min Dynamic V _{OL}		Notes 1, 2	3.3 3.3	3.3 5.0		-0.8 -0.8			V
V _{OLVB}			Notes 1, 2	3.3 3.3	3.3 5.0		-0.8 -1.2			V
V _{IHDA}	Min HIGH Level Dynamic Input Voltage		Notes 1, 3	3.3 3.3	3.3 5.0		2.0 2.0			V
V _{IHDB}			Notes 1, 3	3.3 3.3	3.3 5.0		2.0 3.5			V
V _{ILDA}	Max LOW Level Dynamic Input Voltage		Notes 1, 3	3.3 3.3	3.3 5.0		0.8 0.8			V
V _{ILDB}			Notes 1, 3	3.3 3.3	3.3 5.0		0.8 1.5			V

1. Worst case package.
2. Max number of outputs defined as (n). Data inputs are driven 0 V to V_{CC} level; one output at GND.
3. Max number of data inputs (n) switching. (n-1) inputs switching 0 V to V_{CC} level. Input under test switching: V_{CC} level to threshold (V_{IHD}), 0 V to threshold (V_{ILD}), f = 1 MHz.

MC74LVXC3245

AC ELECTRICAL CHARACTERISTICS

Symbol	Parameter	$T_A = -40 \text{ to } +85^\circ\text{C}; C_L = 50 \text{ pF}$						Unit
		$V_{CCA} = 2.7\text{--}3.6 \text{ V}$ $V_{CCB} = 4.5\text{--}5.5 \text{ V}$			$V_{CCA} = 2.7\text{--}3.6 \text{ V}$ $V_{CCB} = 3.0\text{--}3.6 \text{ V}$			
		Min	Typ (Note 4)	Max	Min	Typ (Note 5)	Max	
t_{PHL} t_{PLH}	Propagation Delay A to B	1.0 1.0	4.8 3.9	8.5 7.0	1.0 1.0	5.5 5.2	9.0 8.5	ns
t_{PHL} t_{PLH}	Propagation Delay B to A	1.0 1.0	3.8 4.3	7.0 8.0	1.0 1.0	4.4 5.1	7.5 8.0	ns
t_{PZL} t_{PZH}	Output Enable Time \overline{OE} to B	1.0 1.0	4.7 4.8	8.5 9.0	1.0 1.0	6.0 6.1	9.5 10.0	ns
t_{PZL} t_{PZH}	Output Enable Time \overline{OE} to A	1.0 1.0	5.9 5.4	10.0 9.5	1.0 1.0	6.4 5.8	10.5 9.5	ns
t_{PHZ} t_{PLZ}	Output Disable Time \overline{OE} to B	1.0 1.0	4.0 3.8	8.5 8.0	1.0 1.0	6.3 4.5	10.0 8.5	ns
t_{PHZ} t_{PLZ}	Output Disable Time \overline{OE} to A	1.0 1.0	4.6 3.1	10.0 7.0	1.0 1.0	5.2 3.4	10.0 7.0	ns
t_{OSHL} t_{OSLH}	Output to Output Skew, Data to Output (Note 6)		1.0	1.5		1.0	1.5	ns

4. Typical values at $V_{CCA} = 3.3 \text{ V}$, $V_{CCB} = 5.0 \text{ V}$ at 25°C .

5. Typical values at $V_{CCA} = 3.3 \text{ V}$, $V_{CCB} = 3.3 \text{ V}$ at 25°C .

6. Skew is defined as the absolute value of the difference between the actual propagation delay for any two separate outputs of the same device. The specification applies to any outputs switching in the same direction, either HIGH-to-LOW (t_{OSHL}) or LOW-to-HIGH (t_{OSLH}); parameter guaranteed by design.

CAPACITIVE CHARACTERISTICS

Symbol	Parameter	Condition	Typical	Unit
C_{IN}	Input Capacitance	$V_{CCA} = 3.3 \text{ V}; V_{CCB} = 5.0 \text{ V}$	4.5	pF
$C_{I/O}$	Input/Output Capacitance	$V_{CCA} = 3.3 \text{ V}; V_{CCB} = 5.0 \text{ V}$	10	pF
C_{PD}	Power Dissipation Capacitance (Measured at 10 MHz)	A→B B→A $V_{CCB} = 5.0 \text{ V}$ $V_{CCA} = 3.3 \text{ V}$	50 40	pF

ORDERING INFORMATION

Device	Package	Shipping [†]
MC74LVXC3245DWR2	SOIC-24	1000 Tape & Reel
MC74LVXC3245DWR2G	SOIC-24 (Pb-Free)	1000 Tape & Reel
MC74LVXC3245DT	TSSOP-24*	62 Units / Rail
MC74LVXC3245DTG	TSSOP-24* (Pb-Free)	62 Units / Rail
MC74LVXC3245DTR2	TSSOP-24*	2500 Tape & Reel
MC74LVXC3245DTR2G	TSSOP-24* (Pb-Free)	2500 Tape & Reel

[†]For information on tape and reel specifications, including part orientation and tape sizes, please refer to our Tape and Reel Packaging Specifications Brochure, BRD8011/D.

*This package is inherently Pb-Free.

MC74LVXC3245

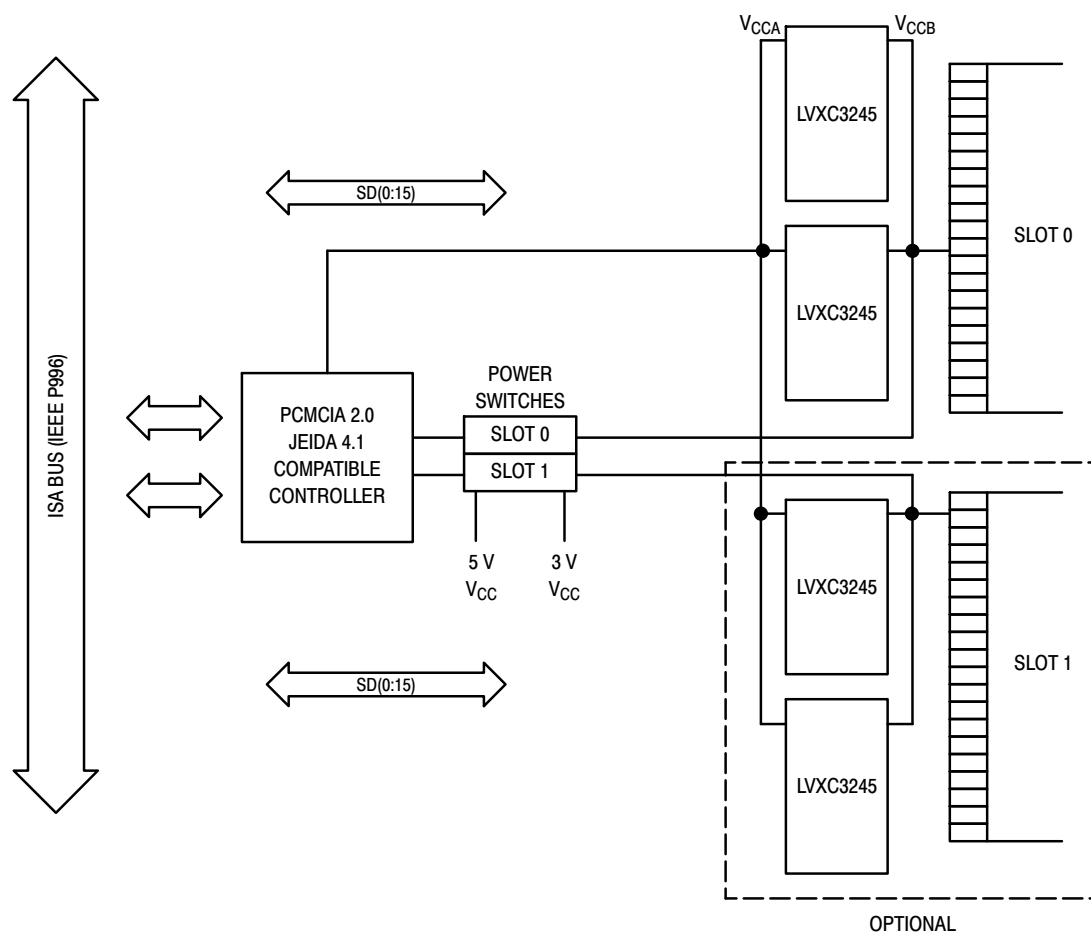

Figure 3. Block Diagram

Configurable I/O Application for PCMCIA Cards

The 74LVXC3245 is a dual-supply device well suited for PCMCIA configurable I/O applications. The LVXC3245 consumes less than 1mW of quiescent power in all modes of operation, making it ideal for low power notebook designs. The LVXC3245 meets all PCMCIA I/O voltage requirements at 5.0 V and 3.3 V operation. By tying the V_{CCB} pin to the card voltage supply, the PCMCIA card will always have

rail-to-rail output swings, maximizing the reliability of the interface.

The V_{CCA} pin must always be tied to a 3.3 V power supply. This voltage connection provides internal references needed to account for variations in V_{CCB}. When connected as in the figure above, the LVXC3245 meets all the voltage and current requirements of the ISA bus standard (IEEE P996).

MC74LVXC3245

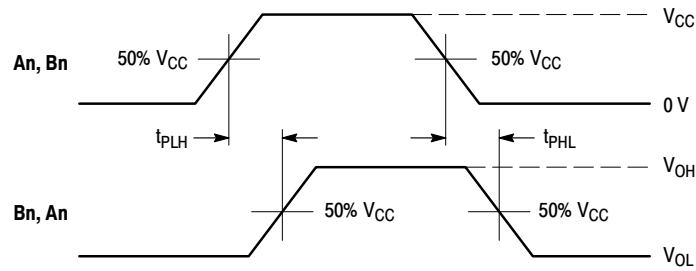

WAVEFORM 1 - PROPAGATION DELAYS
 $t_R = t_F = 2.5 \text{ ns}$, 10% to 90%; $f = 1 \text{ MHz}$; $t_W = 500 \text{ ns}$

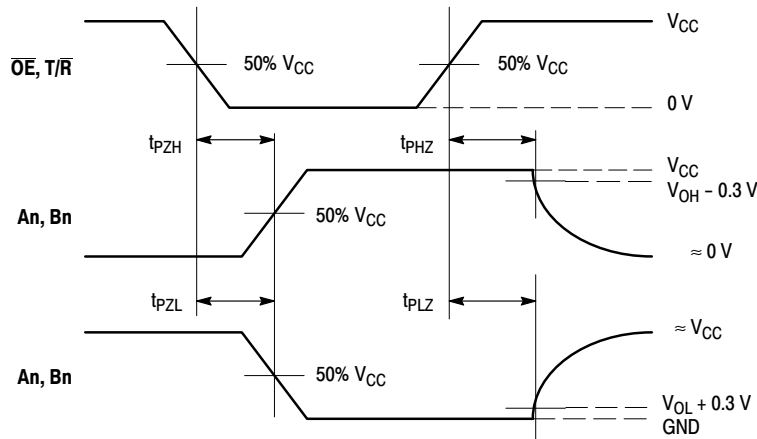

WAVEFORM 2 - OUTPUT ENABLE AND DISABLE TIMES
 $t_R = t_F = 2.5 \text{ ns}$, 10% to 90%; $f = 1 \text{ MHz}$; $t_W = 500 \text{ ns}$

Figure 4. AC Waveforms

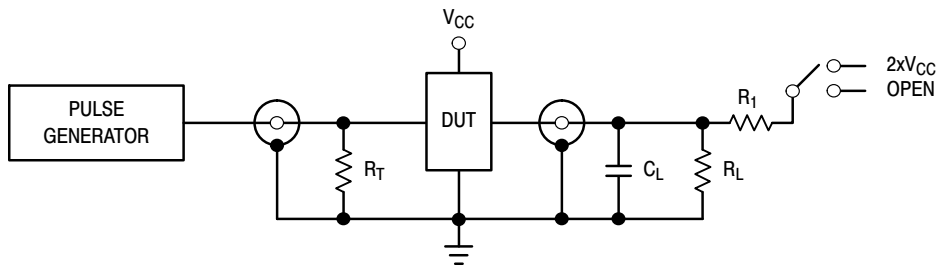

TEST	SWITCH
t_{PLH} , t_{PHL} , t_{PZH} , t_{PHZ}	Open
t_{PZL} , t_{PLZ}	$2xV_{CC}$

$C_L = 50 \text{ pF}$ or equivalent (Includes jig and probe capacitance)
 $R_L = R_1 = 500 \Omega$ or equivalent
 $R_T = Z_{OUT}$ of pulse generator (typically 50Ω)

Figure 5. Test Circuit

MC74LVXC3245

PACKAGE DIMENSIONS

SOIC-24
DW SUFFIX
 CASE 751E-04
 ISSUE E

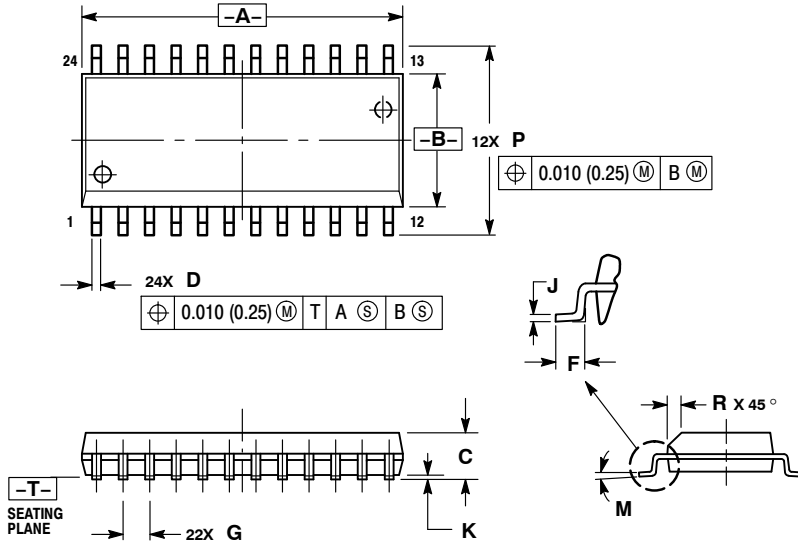

- NOTES:
1. DIMENSIONING AND TOLERANCING PER ANSI Y14.5M, 1982.
 2. CONTROLLING DIMENSION: MILLIMETER.
 3. DIMENSIONS A AND B DO NOT INCLUDE MOLD PROTRUSION.
 4. MAXIMUM MOLD PROTRUSION 0.15 (0.006) PER SIDE.
 5. DIMENSION D DOES NOT INCLUDE DAMBAR PROTRUSION. ALLOWABLE DAMBAR PROTRUSION SHALL BE 0.13 (0.005) TOTAL IN EXCESS OF D DIMENSION AT MAXIMUM MATERIAL CONDITION.

DIM	MILLIMETERS		INCHES	
	MIN	MAX	MIN	MAX
A	15.25	15.54	0.601	0.612
B	7.40	7.60	0.292	0.299
C	2.35	2.65	0.093	0.104
D	0.35	0.49	0.014	0.019
F	0.41	0.90	0.016	0.035
G	1.27 BSC		0.050 BSC	
J	0.23	0.32	0.009	0.013
K	0.13	0.29	0.005	0.011
M	0°	8°	0°	8°
P	10.05	10.55	0.395	0.415
R	0.25	0.75	0.010	0.029

MC74LVXC3245

PACKAGE DIMENSIONS

TSSOP-24
 DT SUFFIX
 CASE 948H-01
 ISSUE A

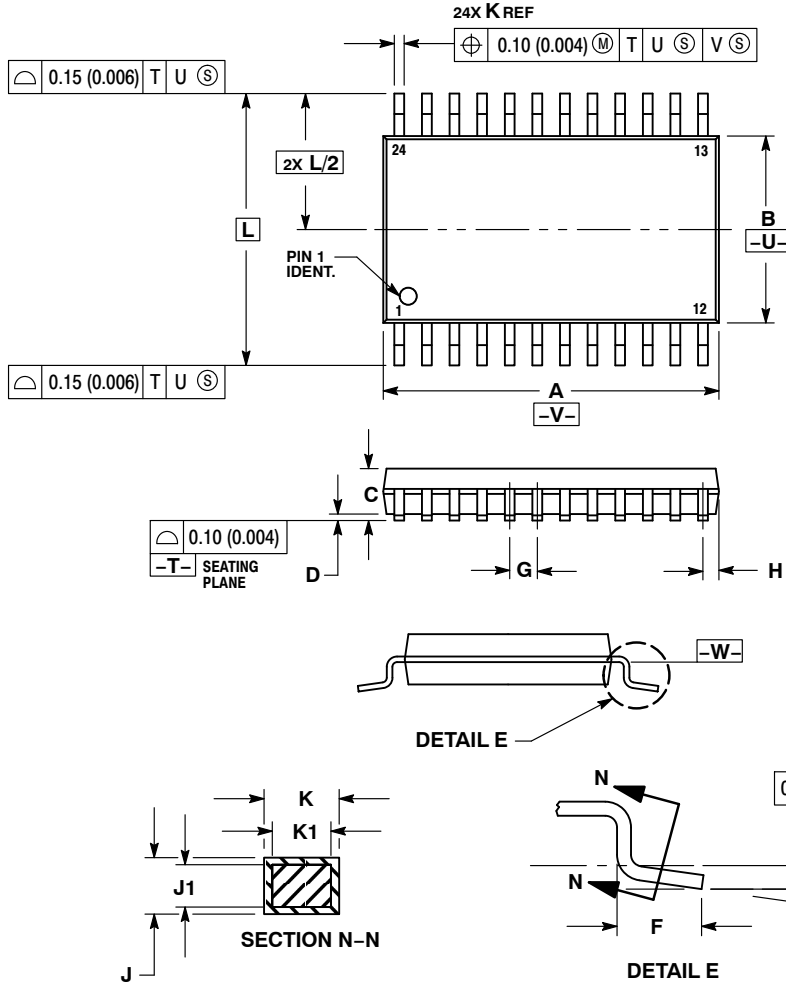

- NOTES:
1. DIMENSIONING AND TOLERANCING PER ANSI Y14.5M, 1982.
 2. CONTROLLING DIMENSION: MILLIMETER.
 3. DIMENSION A DOES NOT INCLUDE MOLD FLASH, PROTRUSIONS OR GATE BURRS. MOLD FLASH OR GATE BURRS SHALL NOT EXCEED 0.15 (0.006) PER SIDE.
 4. DIMENSION B DOES NOT INCLUDE INTERLEAD FLASH OR PROTRUSION. INTERLEAD FLASH OR PROTRUSION SHALL NOT EXCEED 0.25 (0.010) PER SIDE.
 5. DIMENSION K DOES NOT INCLUDE DAMBAR PROTRUSION. ALLOWABLE DAMBAR PROTRUSION SHALL BE 0.08 (0.003) TOTAL IN EXCESS OF THE K DIMENSION AT MAXIMUM MATERIAL CONDITION.
 6. TERMINAL NUMBERS ARE SHOWN FOR REFERENCE ONLY.
 7. DIMENSION A AND B ARE TO BE DETERMINED AT DATUM PLANE -W-.

DIM	MILLIMETERS		INCHES	
	MIN	MAX	MIN	MAX
A	7.70	7.90	0.303	0.311
B	4.30	4.50	0.169	0.177
C	---	1.20	---	0.047
D	0.05	0.15	0.002	0.006
F	0.50	0.75	0.020	0.030
G	0.65 BSC		0.026 BSC	
H	0.27	0.37	0.011	0.015
J	0.09	0.20	0.004	0.008
J1	0.09	0.16	0.004	0.006
K	0.19	0.30	0.007	0.012
K1	0.19	0.25	0.007	0.010
L	6.40 BSC		0.252 BSC	
M	0°	8°	0°	8°

ON Semiconductor and are registered trademarks of Semiconductor Components Industries, LLC (SCILLC). SCILLC reserves the right to make changes without further notice to any products herein. SCILLC makes no warranty, representation or guarantee regarding the suitability of its products for any particular purpose, nor does SCILLC assume any liability arising out of the application or use of any product or circuit, and specifically disclaims any and all liability, including without limitation special, consequential or incidental damages. "Typical" parameters which may be provided in SCILLC data sheets and/or specifications can and do vary in different applications and actual performance may vary over time. All operating parameters, including "Typicals" must be validated for each customer application by customer's technical experts. SCILLC does not convey any license under its patent rights nor the rights of others. SCILLC products are not designed, intended, or authorized for use as components in systems intended for surgical implant into the body, or other applications intended to support or sustain life, or for any other application in which the failure of the SCILLC product could create a situation where personal injury or death may occur. Should Buyer purchase or use SCILLC products for any such unintended or unauthorized application, Buyer shall indemnify and hold SCILLC and its officers, employees, subsidiaries, affiliates, and distributors harmless against all claims, costs, damages, and expenses, and reasonable attorney fees arising out of, directly or indirectly, any claim of personal injury or death associated with such unintended or unauthorized use, even if such claim alleges that SCILLC was negligent regarding the design or manufacture of the part. SCILLC is an Equal Opportunity/Affirmative Action Employer. This literature is subject to all applicable copyright laws and is not for resale in any manner.

PUBLICATION ORDERING INFORMATION

LITERATURE FULFILLMENT:

Literature Distribution Center for ON Semiconductor
 P.O. Box 5163, Denver, Colorado 80217 USA
 Phone: 303-675-2175 or 800-344-3860 Toll Free USA/Canada
 Fax: 303-675-2176 or 800-344-3867 Toll Free USA/Canada
 Email: orderlit@onsemi.com

N. American Technical Support: 800-282-9855 Toll Free
 USA/Canada
 Europe, Middle East and Africa Technical Support:
 Phone: 421 33 790 2910
 Japan Customer Focus Center
 Phone: 81-3-5773-3850

ON Semiconductor Website: www.onsemi.com

Order Literature: <http://www.onsemi.com/orderlit>

For additional information, please contact your local Sales Representative