

Excellent Integrated System Limited

Stocking Distributor

Click to view price, real time Inventory, Delivery & Lifecycle Information:

[Linear Technology](#)
[LTC694CN8-3.3](#)

For any questions, you can email us directly:

sales@integrated-circuit.com

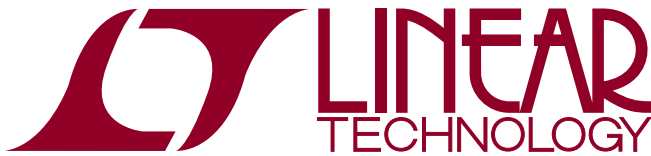

LTC694-3.3/LTC695-3.3

3.3V Microprocessor Supervisory Circuits

FEATURES

- Guaranteed Reset Assertion at $V_{CC} = 1V$
- Pin Compatible with LTC694/LTC695 for 3.3V Systems
- 200 μA Typical Supply Current
- Fast (30ns Typ) Onboard Gating of RAM Chip Enable Signals
- SO-8 and S16 Packages
- 2.90V Precision Voltage Monitor
- Power OK/Reset Time Delay: 200ms or Adjustable
- Minimum External Component Count
- 1 μA Maximum Standby Current
- Voltage Monitor for Power-Fail or Low-Battery Warning
- Thermal Limiting
- Performance Specified Over Temperature

APPLICATIONS

- 3.3V Low Power Systems
- Critical μP Power Monitoring
- Intelligent Instruments
- Battery-Powered Computers and Controllers
- Automotive Systems

Δ , LT, LTC, LTM, Linear Technology and the Linear logo are registered trademarks of Linear Technology Corporation. All other trademarks are the property of their respective owners.

DESCRIPTION

The LTC[®]694-3.3/LTC695-3.3 provide complete 3.3V power supply monitoring and battery control functions. These include power-on reset, battery back-up, RAM write protection, power failure warning and watchdog timing. The devices are pin compatible upgrades of the LTC694/LTC695 that are optimized for 3.3V systems. Operating power consumption has been reduced to 0.6mW (typical) and 3 μW maximum in battery back-up mode. Microprocessor reset and memory write protection are provided when the supply falls below 2.9V. The \overline{RESET} output is guaranteed to remain logic low with V_{CC} as low as 1V.

The LTC694-3.3/LTC695-3.3 power the active RAMs with a charge pumped NMOS power switch to achieve low dropout and low supply current. When primary power is lost, auxiliary power, connected to the battery input pin, powers the RAMs in standby through an efficient PMOS switch.

For an early warning of impending power failure, the LTC694-3.3/LTC695-3.3 provide an internal comparator with a user-defined threshold. An internal watchdog timer is also available, which forces the reset pins to active states when the watchdog input is not toggled prior to a preset timeout period.

TYPICAL APPLICATION

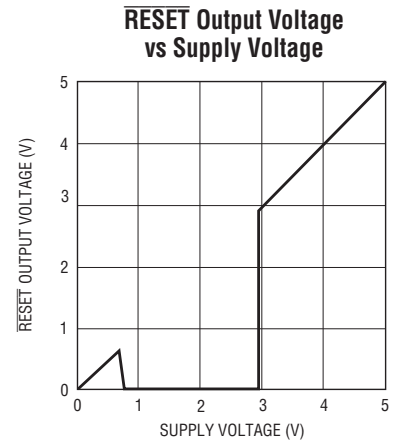
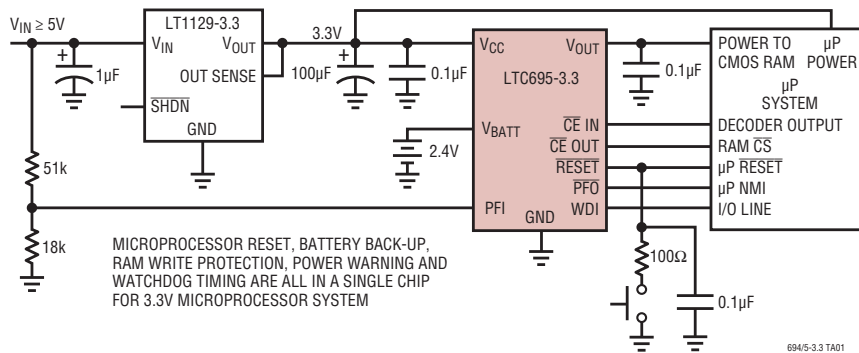

LTC694-3.3/LTC695-3.3

ABSOLUTE MAXIMUM RATINGS (Notes 1 and 2)

Terminal Voltage

V_{CC}	-0.3V to 6V
V_{BATT}	-0.3V to 6V
All Other Inputs	-0.3V to ($V_{OUT} + 0.3V$)

Input Current

V_{CC}	100mA
V_{BATT}	25mA
GND.....	10mA

V_{OUT} Output Current Short-Circuit Protected

Power Dissipation 500mW

Operating Temperature Range

LTC694C-3.3/LTC695C-3.3..... 0°C to 70°C

LTC694I-3.3/LTC695I-3.3 -40°C to 85°C

Storage Temperature Range -65°C to 150°C

Lead Temperature (Soldering, 10 sec)..... 300°C

PIN CONFIGURATION

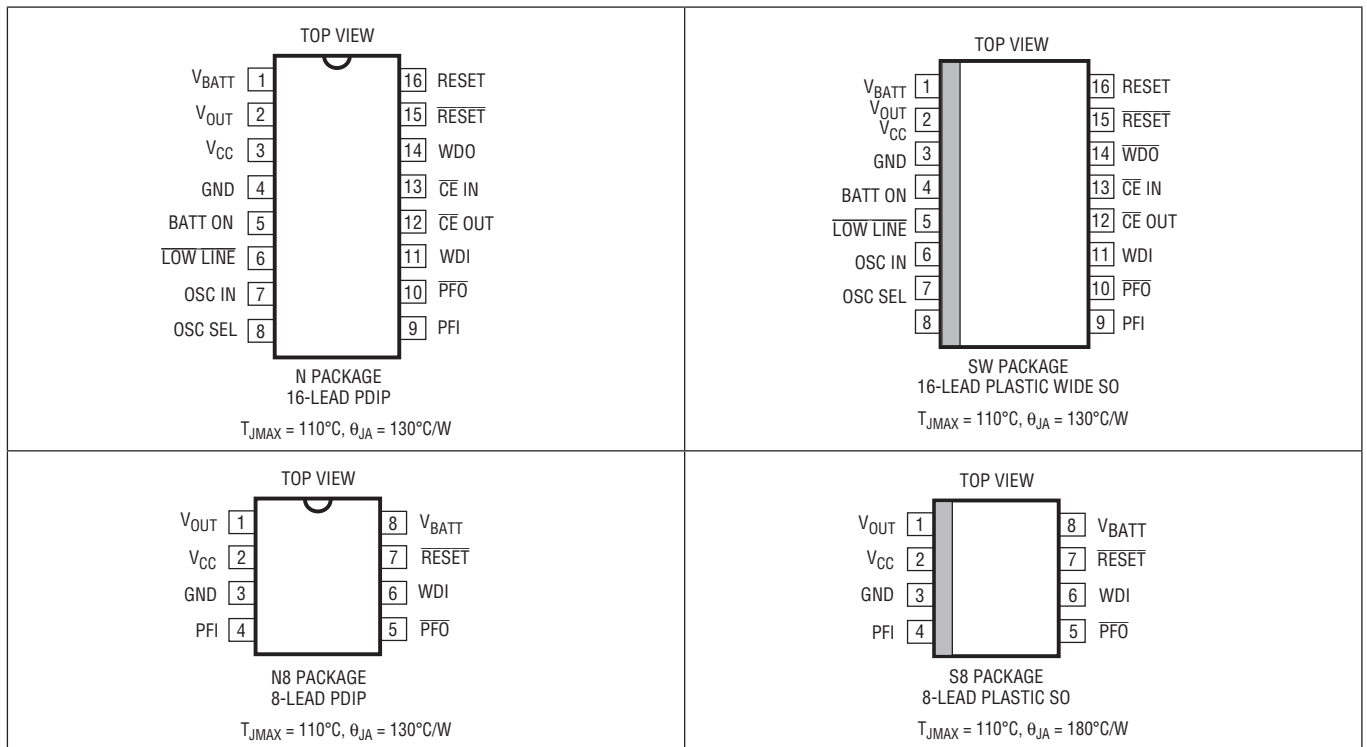

LTC694-3.3/LTC695-3.3

ORDER INFORMATION

LEAD FREE FINISH	TAPE AND REEL	PART MARKING	PACKAGE DESCRIPTION	TEMPERATURE RANGE
LTC695CN-3.3#PBF	LTC695CN-3.3#TRPBF	LTC695CN-3.3	16-Lead PDIP	0°C to 70°C
LTC695IN-3.3#PBF	LTC695IN-3.3#TRPBF	LTC695IN-3.3	16-Lead PDIP	-40°C to 85°C
LTC695CSW-3.3#PBF	LTC695CSW-3.3#TRPBF	LTC695CSW-3.3	16-Lead Plastic Wide SO	0°C to 70°C
LTC695ISW-3.3#PBF	LTC695ISW-3.3#TRPBF	LTC695ISW-3.3	16-Lead Plastic Wide SO	-40°C to 85°C
LTC694CN8-3.3#PBF	LTC694CN8-3.3#TRPBF	LTC694CN8-3.3	8-Lead PDIP	0°C to 70°C
LTC694IN8-3.3#PBF	LTC694IN8-3.3#TRPBF	LTC694IN8-3.3	8-Lead PDIP	-40°C to 85°C
LTC694CS8-3.3#PBF	LTC694CS8-3.3#TRPBF	6943	8-Lead Plastic SO	0°C to 70°C
LTC694IS8-3.3#PBF	LTC694IS8-3.3#TRPBF	69413	8-Lead Plastic SO	-40°C to 85°C

Consult LTC Marketing for parts specified with wider operating temperature ranges.

Consult LTC Marketing for information on non-standard lead based finish parts.

Consult LTC Marketing for military grade parts.

For more information on lead free part marking, go to: <http://www.linear.com/leadfree/>

For more information on tape and reel specifications, go to: <http://www.linear.com/tapeandreel/>

PRODUCT SELECTION GUIDE

	PINS	RESET THRESHOLD (V)	WATCHDOG TIMER	BATTERY BACK-UP	POWER-FAIL WARNING	RAM WRITE PROTECT	PUSH-BUTTON RESET	CONDITIONAL BATTERY BACK-UP
LTC694-3.3	8	2.90	X	X	X			
LTC695-3.3	16	2.90	X	X	X	X		
LTC690	8	4.65	X	X	X			
LTC691	16	4.65	X	X	X	X		
LTC694	8	4.65	X	X	X			
LTC695	16	4.65	X	X	X	X		
LTC699	8	4.65	X					
LTC1232	8	4.37/4.62	X				X	
LTC1235	16	4.65	X	X	X	X	X	X

LTC694-3.3/LTC695-3.3

ELECTRICAL CHARACTERISTICS The ● denotes the specifications which apply over the full operating temperature range, otherwise specifications are at $T_A = 25^\circ\text{C}$. $V_{CC} = 3.3\text{V}$, $V_{BATT} = 2\text{V}$, unless otherwise noted.

PARAMETER	CONDITIONS		MIN	TYP	MAX	UNITS
Battery Back-Up Switching						
Operating Voltage Range	V_{CC}	●	3.0		5.50	V
	V_{BATT}	●	1.5		2.75	V
V_{OUT} Output Voltage	$I_{OUT} = 1\text{mA}$	●	$V_{CC} - 0.1$	$V_{CC} - 0.01$		V
			$V_{CC} - 0.2$	$V_{CC} - 0.01$		V
V_{OUT} in Battery Back-Up Mode	$I_{OUT} = 50\text{mA}$	●	$V_{CC} - 0.8$	$V_{CC} - 0.4$		V
	$I_{OUT} = 250\mu\text{A}$, $V_{CC} < V_{BATT}$	●	$V_{BATT} - 0.1$	$V_{BATT} - 0.02$		V
Supply Current (Exclude I_{OUT})	$I_{OUT} \leq 50\mu\text{A}$, $V_{CC} = 3.6\text{V}$	●		0.2	0.6	mA
Supply Current in Battery Back-Up Mode	$V_{CC} = 0\text{V}$, $V_{BATT} = 2\text{V}$	●		0.2	1.0	mA
				0.04	1	μA
Battery Standby Current (+ = Discharge, - = Charge)	$3.6\text{V} > V_{CC} > V_{BATT} + 0.2\text{V}$	●	-0.02		0.02	μA
			-0.10		0.10	μA
Battery Switchover Threshold ($V_{CC} - V_{BATT}$)	Power-Up			70		mV
	Power-Down			50		mV
Battery Switchover Hysteresis				20		mV
BATT ON Output Voltage (Note 4)	$I_{SINK} = 800\mu\text{A}$	●			0.3	V
BATT ON Output Short-Circuit Current (Note 4)	BATT ON = V_{OUT} , Sink Current BATT ON = 0V, Source Current	●	0.5	25	25	mA
				1		μA
Reset and Watchdog Timer						
Reset Voltage Threshold		●	2.8	2.9	3.0	V
Reset Threshold Hysteresis				40		mV
Reset Active Time	OSC SEL HIGH, $V_{CC} = 3\text{V}$	●	160	200	240	ms
			140	200	280	ms
Watchdog Timeout Period, Internal Oscillator	Long Period, $V_{CC} = 3\text{V}$	●	1.2	1.6	2.0	sec
			1.0	1.6	2.25	sec
	Short Period, $V_{CC} = 3\text{V}$	●	80	100	120	ms
			70	100	140	ms
Watchdog Timeout Period, External Clock (Note 5)	Long Period, $V_{CC} = 3\text{V}$ Short Period, $V_{CC} = 3\text{V}$	●	4032		4097	Clock
		●	960		1025	Cycles
Reset Active Time PSRR				4		ms/V
Watchdog Timeout Period PSRR, Internal OSC	Short Period Long Period			2		ms/V
				32		ms/V
Minimum WDI Input Pulse Width	$V_{IL} = 0.4\text{V}$, $V_{IH} = 3\text{V}$	●	200			ns
$\overline{\text{RESET}}$ Output Voltage at $V_{CC} = 1\text{V}$	$I_{SINK} = 10\mu\text{A}$, $V_{CC} = 1\text{V}$	●		4	200	mV
$\overline{\text{RESET}}$ and $\overline{\text{LOW LINE}}$ Output Voltage (Note 4)	$I_{SINK} = 400\mu\text{A}$, $V_{CC} = 2.8\text{V}$ $I_{SOURCE} = 0.1\mu\text{A}$, $V_{CC} = 3\text{V}$	●			0.3	V
		●	2.3			V
$\overline{\text{RESET}}$ and $\overline{\text{WD0}}$ Output Voltage (Note 4)	$I_{SINK} = 400\mu\text{A}$, $V_{CC} = 3\text{V}$ $I_{SOURCE} = 0.1\mu\text{A}$, $V_{CC} = 2.8\text{V}$	●			0.3	V
		●	2.3			V
$\overline{\text{RESET}}$, $\overline{\text{RESET}}$, $\overline{\text{WD0}}$, $\overline{\text{LOW LINE}}$ Output Short-Circuit Current (Note 4)	Output Source Current Output Sink Current	●	1	3	25	μA
				9		mA
WDI Input Threshold	Logic Low Logic High	●			0.4	V
		●	2.3			V
WDI Input Current	$\text{WDI} = V_{OUT}$ $\text{WDI} = 0\text{V}$	●		4	50	μA
		●	-50	-8		μA

LTC694-3.3/LTC695-3.3

ELECTRICAL CHARACTERISTICS

The ● denotes the specifications which apply over the full operating temperature range, otherwise specifications are at $T_A = 25^\circ\text{C}$. $V_{CC} = 3.3\text{V}$, $V_{BATT} = 2\text{V}$, unless otherwise noted.

PARAMETER	CONDITIONS		MIN	TYP	MAX	UNITS
Power-Fail Detector						
PFI Input Threshold		●	1.25	1.3	1.35	V
PFI Input Threshold PSRR				0.3		mV/V
PFI Input Current		●		±0.01	±25	nA
PFO Output Voltage (Note 4)	$I_{SINK} = 800\mu\text{A}$ $I_{SOURCE} = 0.1\mu\text{A}$	● ●	2.3		0.3	V V
PFO Short-Circuit Source Current (Note 4)	PFI = HIGH, PFO = 0V PFI = LOW, PFO = V_{OUT}	●	1	3 17	25	μA μA
PFI Comparator Response Time (Falling)	$\Delta V_{IN} = -20\text{mV}$, $V_{OD} = 15\text{mV}$			2		μs
PFI Comparator Response Time (Rising) (Note 4)	$\Delta V_{IN} = 20\text{mV}$, $V_{OD} = 15\text{mV}$ with $10\text{k}\Omega$ Pull-Up			40 8		μs μs
Chip Enable Gating						
$\overline{\text{CE}}$ IN Threshold	V_{IL} V_{IH}		1.9		0.45	V V
$\overline{\text{CE}}$ IN Pull-Up Current (Note 6)				3		μA
$\overline{\text{CE}}$ OUT Output Voltage	$I_{SINK} = 800\mu\text{A}$ $I_{SOURCE} = 400\mu\text{A}$ $I_{SOURCE} = 1\mu\text{A}$, $V_{CC} = 0\text{V}$	● ● ●			0.3	V V V
$\overline{\text{CE}}$ IN Propagation Delay	$C_L = 20\text{pF}$	●		30	50	ns
$\overline{\text{CE}}$ OUT Output Short-Circuit Current	Output Source Current Output Sink Current			15 20		mA mA
Oscillator						
OSC IN Input Current (Note 6)				±2		μA
OSC SEL Input Pull-Up Current (Note 6)				5		μA
OSC IN Frequency Range	OSC SEL = 0V OSC SEL = 0V, $C_A = 47\text{pF}$	●	0	4	125	kHz kHz

Note 1: Stresses beyond those listed under Absolute Maximum Ratings may cause permanent damage to the device. Exposure to any Absolute Maximum Rating condition for extended periods may affect device reliability and lifetime.

Note 2: All voltage values are with respect to GND.

Note 3: For military temperature range parts, consult the factory.

Note 4: The output pins of BATT ON, LOW LINE, PFO, WDO, RESET and RESET have weak internal pull-ups of typically $3\mu\text{A}$. However, external pull-up resistors may be used when higher speed is required.

Note 5: The external clock feeding into the circuit passes through the oscillator before clocking the watchdog timer. Variation in the timeout period is caused by phase errors which occur when the oscillator divides the external clock by 64. The resulting variation in the timeout period is 64 plus one clock of jitter.

Note 6: The input pins of $\overline{\text{CE}}$ IN, OSC IN and OSC SEL have weak internal pull-ups which pull to the supply when the input pins are floating.

LTC694-3.3/LTC695-3.3

TYPICAL PERFORMANCE CHARACTERISTICS

Output Voltage vs Load Current

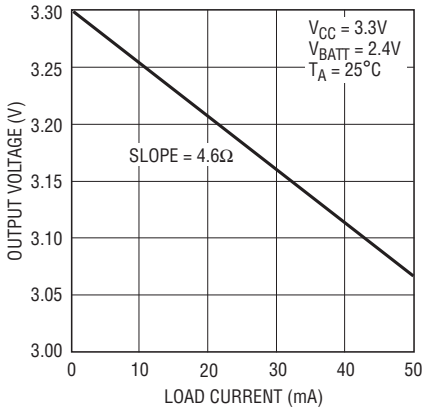

694/5-3.3 G01

Output Voltage vs Load Current

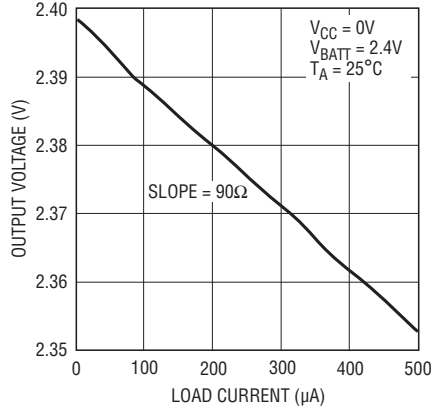

694/5-3.3 G02

Power Failure Input Threshold vs Temperature

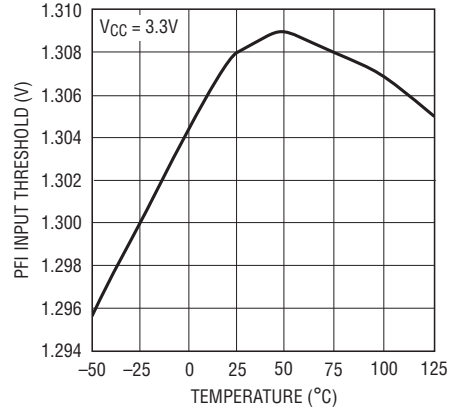

694/5-3.3 G03

Power-Fail Comparator Response Time

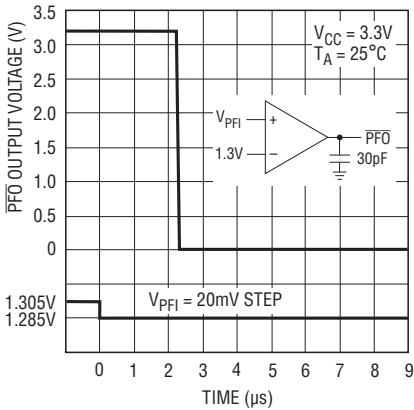

694/5-3.3 G04

Power-Fail Comparator Response Time

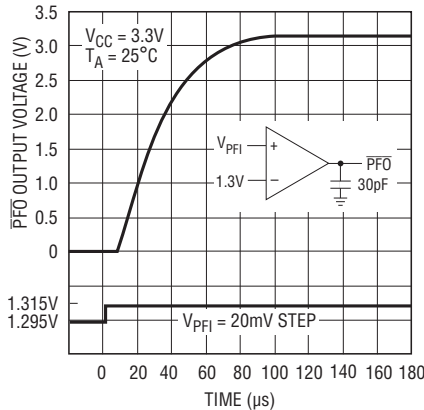

694/5-3.3 G05

Power-Fail Comparator Response Time with Pull-Up Resistor

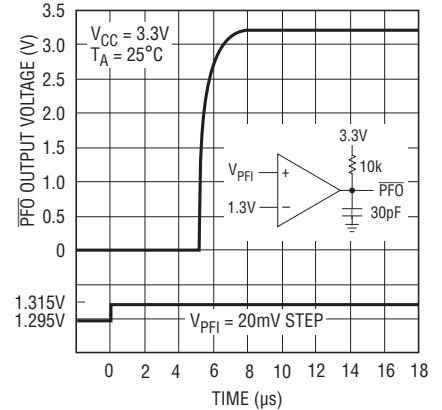

694/5-3.3 G06

Reset Active Time vs Temperature

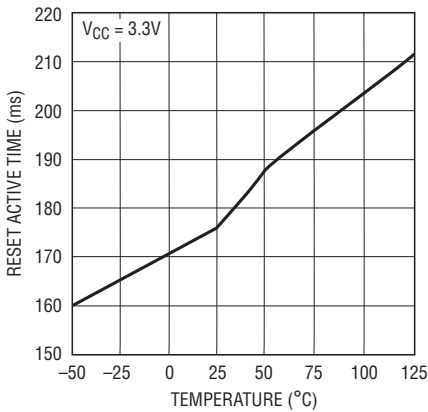

694/5-3.3 G07

Reset Voltage Threshold vs Temperature

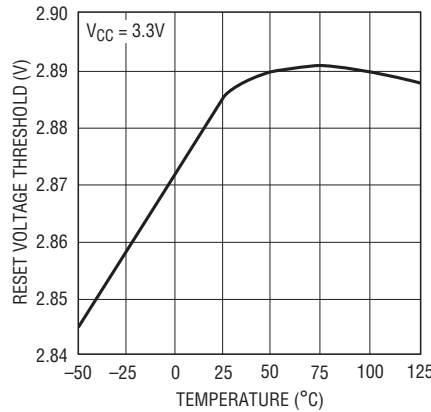

694/5-3.3 G08

RESET Output Voltage vs Supply Voltage

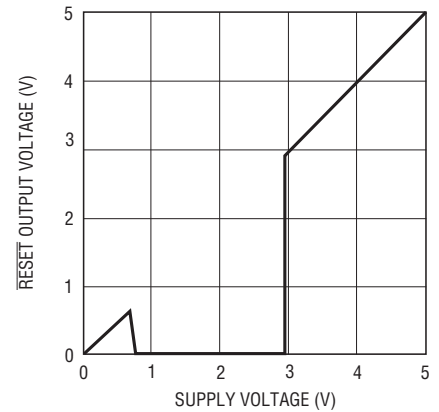

694/5-3.3 G09

69453fb

LTC694-3.3/LTC695-3.3

PIN FUNCTIONS

BATT ON: Battery On Logic Output from Comparator C2. BATT ON goes low when V_{OUT} is internally connected to V_{CC} . The output typically sinks 25mA and can provide base drive for an external PNP transistor to increase the output current above the 50mA rating of V_{OUT} . BATT ON goes high when V_{OUT} is internally switched to V_{BATT} .

\overline{CE} IN: Logic Input to the Chip Enable Gating Circuit. \overline{CE} IN can be derived from microprocessor's address line and/or decoder output. See the Applications Information section and Figure 5 for additional information.

\overline{CE} OUT: Logic Output on the Chip Enable Gating Circuit. When V_{CC} is above the reset voltage threshold, \overline{CE} OUT is a buffered replica of \overline{CE} IN. When V_{CC} is below the reset voltage threshold \overline{CE} OUT is forced high (see Figure 5).

GND: Ground Pin.

LOW LINE: Logic Output from Comparator C1. $\overline{LOW LINE}$ indicates a low line condition at the V_{CC} input. When V_{CC} falls below the reset voltage threshold (2.90V typically), $\overline{LOW LINE}$ goes low. As soon as V_{CC} rises above the reset voltage threshold, $\overline{LOW LINE}$ returns high (see Figure 1). $\overline{LOW LINE}$ goes low when V_{CC} drops below V_{BATT} (see Table 1).

OSC IN: Oscillator Input. OSC IN can be driven by an external clock signal or an external capacitor can be connected between OSC IN and GND when OSC SEL is forced low. In this configuration the nominal reset active time and watchdog timeout period are determined by the number of clocks or set by the formula (see the Applications Information section). When OSC SEL is high or floating, the internal oscillator is enabled and the reset active time is fixed at 200ms typical for the LTC695-3.3. OSC IN selects between the 1.6 seconds and 100ms typical watchdog timeout periods. In both cases, the timeout period immediately after a reset is 1.6 seconds typical.

OSC SEL: Oscillator Selection Input. When OSC SEL is high or floating, the internal oscillator sets the reset active time and watchdog timeout period. Forcing OSC SEL low, allows OSC IN to be driven from an external clock signal or an external capacitor can be connected between OSC IN and GND.

PFI: Power Failure Input. PFI is the noninverting input to the power-fail comparator, C3. The inverting input is internally connected to a 1.3V reference. The power failure output remains high when PFI is above 1.3V and goes low when PFI is below 1.3V. Connect PFI to GND or V_{OUT} when C3 is not used.

\overline{PFO} : Power Failure Output from C3. \overline{PFO} remains high when PFI is above 1.3V and goes low when PFI is below 1.3V. When V_{CC} is lower than V_{BATT} , C3 is shut down and \overline{PFO} is forced low.

RESET: Active High Logic Output. It is the inverse of \overline{RESET} .

\overline{RESET} : Logic Output for μ P Reset Control. Whenever V_{CC} falls below either the reset voltage threshold (2.90V, typically) or V_{BATT} , \overline{RESET} goes active low. After V_{CC} returns to 3.3V, the reset pulse generator forces \overline{RESET} to remain active low for a minimum of 140ms. When the watchdog timer is enabled but not serviced prior to a preset timeout period, the reset pulse generator also forces \overline{RESET} to active low for a minimum of 140ms for every preset timeout period (see Figure 11). The reset active time is adjustable on the LTC695-3.3. An external push-button reset can be used in connection with the \overline{RESET} output. See Push-Button Reset in the Applications Information section.

V_{BATT} : Back-Up Battery Input. When V_{CC} falls below V_{BATT} , auxiliary power connected to V_{BATT} , is delivered to V_{OUT} through PMOS switch, M2. If back-up battery or auxiliary power is not used, V_{BATT} should be connected to GND.

V_{CC} : 3.3V Supply Input. The V_{CC} pin should be bypassed with a 0.1 μ F capacitor.

V_{OUT} : Voltage Output for Backed Up Memory. Bypass with a capacitor of 0.1 μ F or greater. During normal operation, V_{OUT} obtains power from V_{CC} through an NMOS power switch, M1, which can deliver up to 50mA and has a typical on resistance of 5 Ω . When V_{CC} is lower than V_{BATT} , V_{OUT} is internally switched to V_{BATT} . If V_{OUT} and V_{BATT} are not used, connect V_{OUT} to V_{CC} .

LTC694-3.3/LTC695-3.3

PIN FUNCTIONS

WDI: Watchdog Input. WDI is a three-level input. Driving WDI either high or low for longer than the watchdog timeout period, forces both RESET and WDO low. Floating WDI disables the watchdog timer. The timer resets itself with each transition of the watchdog input (see Figure 11).

WDO: Watchdog Logic Output. When the watchdog input remains either high or low for longer than the watchdog timeout period, WDO goes low. WDO is set high whenever there is a transition on the WDI pin, or $\overline{\text{LOW LINE}}$ goes low. The watchdog timer can be disabled by floating WDI (see Figure 11).

BLOCK DIAGRAM

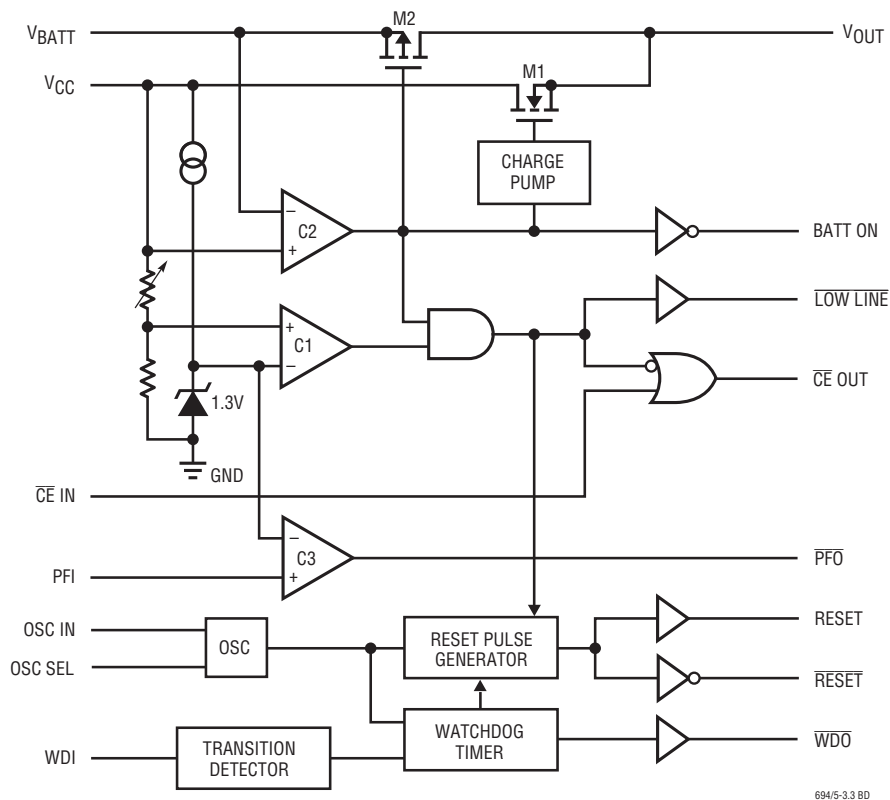

LTC694-3.3/LTC695-3.3

APPLICATIONS INFORMATION

Microprocessor Reset

The LTC694-3.3/LTC695-3.3 use a bandgap voltage reference and a precision voltage comparator C1 to monitor the 3.3V supply input on V_{CC} (see the Block Diagram). When V_{CC} falls below the reset voltage threshold, the $\overline{\text{RESET}}$ output is forced to active low state. The reset voltage threshold accounts for a 10% variation on V_{CC} , so the $\overline{\text{RESET}}$ output becomes active low when V_{CC} falls below 3.0V (2.9V typical). On power-up, the $\overline{\text{RESET}}$ signal is held active low for a minimum of 140ms after reset voltage threshold is reached to allow the power supply and microprocessor to stabilize. The reset active time is adjustable on the LTC695-3.3. On power-down, the $\overline{\text{RESET}}$ signal remains active low even with V_{CC} as low as 1V. This capability helps hold the microprocessor in stable shutdown condition. Figure 1 shows the timing diagram of the $\overline{\text{RESET}}$ signal.

The precision voltage comparator, C1, typically has 40mV of hysteresis which ensures that glitches at V_{CC} pin do not activate the $\overline{\text{RESET}}$ output. Response time is typically 10ms. To help prevent mistriggering due to transient loads, the V_{CC} pin should be bypassed with a 0.1 μF capacitor with the leads trimmed as short as possible.

The LTC695-3.3 has two additional outputs: $\overline{\text{RESET}}$ and $\overline{\text{LOW LINE}}$. $\overline{\text{RESET}}$ is an active high output and is the inverse of $\overline{\text{RESET}}$. $\overline{\text{LOW LINE}}$ is the output of the precision voltage comparator C1. When V_{CC} falls below the reset voltage threshold, $\overline{\text{LOW LINE}}$ goes low. $\overline{\text{LOW LINE}}$ returns high as soon as V_{CC} rises above the reset voltage threshold.

Battery Switchover

The battery switchover circuit compares V_{CC} to the V_{BATT} input, and connects V_{OUT} to whichever is higher. When V_{CC} rises to 70mV above V_{BATT} , the battery switchover comparator, C2, connects V_{OUT} to V_{CC} through a charge pumped NMOS power switch, M1. When V_{CC} falls to 50mV above V_{BATT} , C2 connects V_{OUT} to V_{BATT} through a PMOS switch, M2. C2 has typically 20mV of hysteresis to prevent spurious switching when V_{CC} remains nearly equal to V_{BATT} . The response time of C2 is approximately 20 μs .

During normal operation, the LTC694-3.3/LTC695-3.3 use a charge-pumped NMOS power switch to achieve low dropout and low supply current. This power switch can deliver up to 50mA to V_{OUT} from V_{CC} and has a typical on resistance of 5 Ω . The V_{OUT} pin should be bypassed with a capacitor of 0.1 μF or greater to ensure stability. Use of a larger bypass capacitor is advantageous for supplying current to heavy transient loads.

When operating currents larger than 50mA are required from V_{OUT} , or a lower dropout ($V_{CC} - V_{\text{OUT}}$ voltage differential) is desired, the LTC695-3.3 should be used. This product provides BATT ON output to drive the base of an external PNP transistor (Figure 2). If higher currents are needed with the LTC694-3.3, a high current Schottky diode can be connected from the V_{CC} pin to the V_{OUT} pin to supply the extra current.

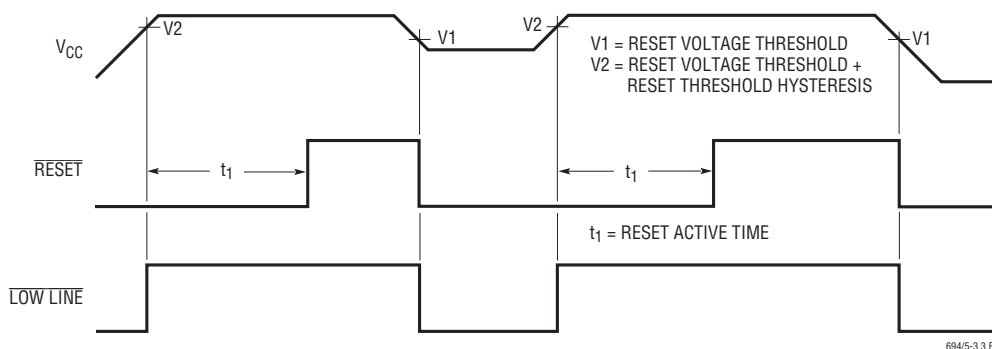

Figure 1. Reset Active Time

LTC694-3.3/LTC695-3.3

APPLICATIONS INFORMATION

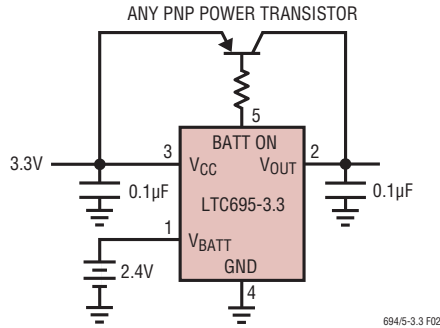

Figure 2. Using BATT ON to Drive External PNP Transistor

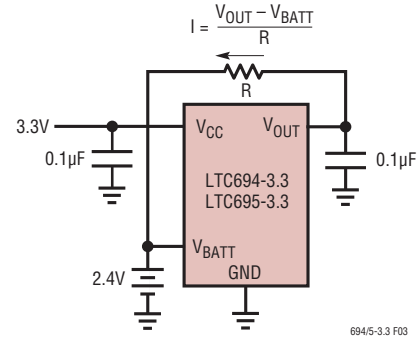

Figure 3. Charging External Battery Through V_{OUT}

The LTC694-3.3/LTC695-3.3 are protected for safe area operation with short-circuit limit. Output current is limited to approximately 200mA. If the device is overloaded for a long period of time, thermal shutdown turns the power switch off until the device cools down. The threshold temperature for thermal shutdown is approximately 155°C with about 10°C of hysteresis which prevents the device from oscillating in and out of shutdown.

The PNP switch used in competitive devices was not chosen for the internal power switch because it injects unwanted current into the substrate. This current is collected by the V_{BATT} pin in competitive devices and adds to the charging current of the battery which can damage lithium batteries. The LTC694-3.3/LTC695-3.3 use a charge-pumped NMOS power switch to eliminate unwanted charging current while achieving low dropout and low supply current. Since no current goes to the substrate, the current collected by V_{BATT} pin is strictly junction leakage.

A 125Ω PMOS switch connects the V_{BATT} input to V_{OUT} in battery back-up mode. The switch is designed for very low dropout voltage (input-to-output differential). This feature is advantageous for low current applications such as battery back-up in CMOS RAM and other low power CMOS circuitry. The supply current in battery back-up mode is 1µA maximum.

The operating voltage at the V_{BATT} pin ranges from 1.5V to 2.75V. The charging resistor for rechargeable batteries should be connected to V_{OUT} since this eliminates the discharge path that exists when the resistor is connected to V_{CC} (Figure 3).

Replacing the Back-Up Battery

When changing the back-up battery with system power on, spurious resets can occur while the battery is removed due to battery standby current. Although battery standby current is only a tiny leakage current, it can still charge up the stray capacitance on the V_{BATT} pin. The oscillation cycle is as follows: When V_{BATT} reaches within 50mV of V_{CC}, the LTC694-3.3/LTC695-3.3 switch to battery backup. V_{OUT} pulls V_{BATT} low and the device goes back to normal operation. The leakage current then charges up the V_{BATT} pin again and the cycle repeats.

If spurious resets during battery replacement pose no problems, then no action is required. Otherwise, a resistor from V_{BATT} to GND will hold the pin low while changing the battery. For example, the battery standby current is 1µA maximum over temperature so the external resistor required to hold V_{BATT} below V_{CC} is:

$$R \leq \frac{V_{CC} - 50\text{mV}}{1\mu\text{A}}$$

With V_{CC} = 3V, a 2.7M resistor will work. With a 2V battery, this resistor will draw only 0.7µA from the battery, which is negligible in most cases.

LTC694-3.3/LTC695-3.3

APPLICATIONS INFORMATION

If battery connections are made through long wires, a 10Ω to 100Ω series resistor and a $0.1\mu\text{F}$ capacitor are recommended to prevent any overshoot beyond V_{CC} due to the lead inductance (Figure 4).

Table 1 shows the state of each pin during battery back-up. When the battery switchover section is not used, connect V_{BATT} to GND and V_{OUT} to V_{CC} .

Table 1. Input and Output Status in Battery Back-Up Mode

SIGNAL	STATUS
V_{CC}	C2 monitors V_{CC} for active switchover.
V_{OUT}	V_{OUT} is connected to V_{BATT} through an internal PMOS switch.
V_{BATT}	The supply current is $1\mu\text{A}$ maximum.
BATT ON	Logic high. The open-circuit output voltage is equal to V_{OUT} .
PFI	Power failure input is ignored.
PFO	Logic low.
RESET	Logic low.
RESET	Logic high. The open-circuit output voltage is equal to V_{OUT} .
LOW LINE	Logic low.
WDI	Watchdog input is ignored.
WDO	Logic high. The open-circuit output voltage is equal to V_{OUT} .
$\overline{\text{CE}} \text{ IN}$	Chip Enable input is ignored.
$\overline{\text{CE}} \text{ OUT}$	Logic high. The open-circuit output voltage is equal to V_{OUT} .
OSC IN	OSC IN is ignored.
OSC SEL	OSC SEL is ignored.

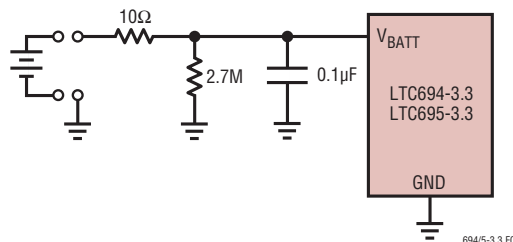

Figure 4. $10\Omega/0.1\mu\text{F}$ Combination Eliminates Inductive Overshoot and Prevents Spurious Resets During Battery Replacement. The $2.7\text{M}\Omega$ Pulls the V_{BATT} Pin to Ground While the Battery is Removed, Eliminating Spurious Resets

Memory Protection

The LTC695-3.3 includes memory protection circuitry which ensures the integrity of the data in memory by preventing write operations when V_{CC} is at invalid level. Two additional pins, $\overline{\text{CE}} \text{ IN}$ and $\overline{\text{CE}} \text{ OUT}$, control the Chip Enable or Write inputs of CMOS RAM. When V_{CC} is 3.3V, $\overline{\text{CE}} \text{ OUT}$ follows $\overline{\text{CE}} \text{ IN}$ with a typical propagation delay of 30ns. When V_{CC} falls below the reset voltage threshold or V_{BATT} , $\overline{\text{CE}} \text{ OUT}$ is forced high, independent of $\overline{\text{CE}} \text{ IN}$. $\overline{\text{CE}} \text{ OUT}$ is an alternative signal to drive the $\overline{\text{CE}}$, CS, or Write input of battery backed up CMOS RAM. $\overline{\text{CE}} \text{ OUT}$ can also be used to drive the Store or Write input of an EEPROM, EAROM or NOVRAM to achieve similar protection. Figure 5 shows the timing diagram of $\overline{\text{CE}} \text{ IN}$ and $\overline{\text{CE}} \text{ OUT}$.

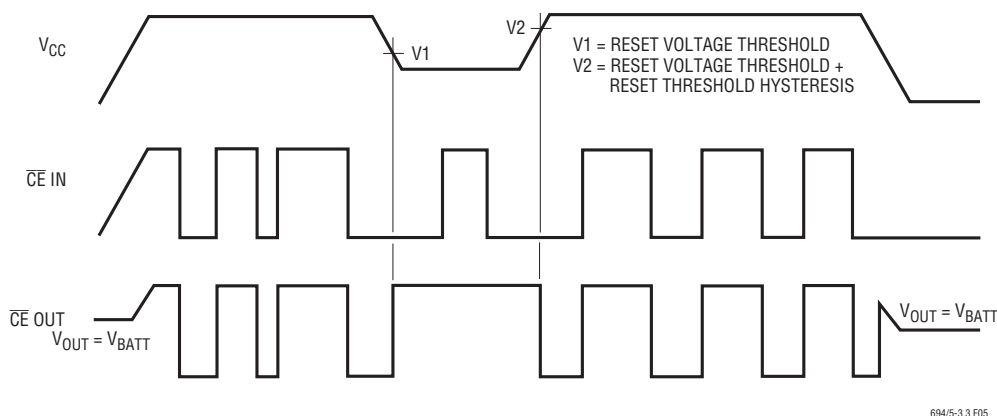

Figure 5. Timing Diagram for $\overline{\text{CE}} \text{ IN}$ and $\overline{\text{CE}} \text{ OUT}$

LTC694-3.3/LTC695-3.3

APPLICATIONS INFORMATION

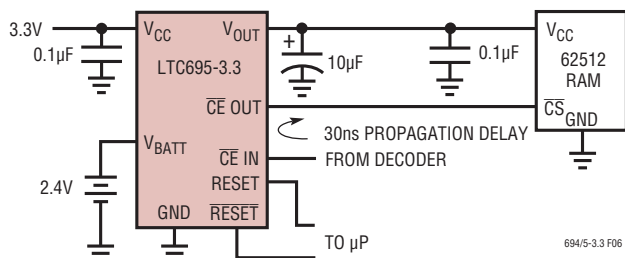

Figure 6. A Typical Nonvolatile CMOS RAM Application

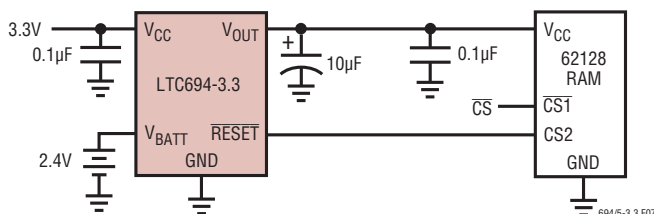

Figure 7. Write Protect for RAM with LTC694-3.3

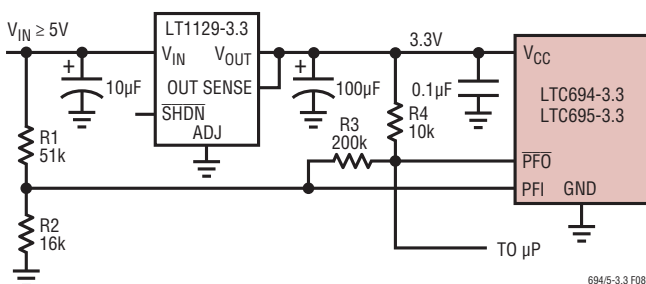

Figure 8. Monitoring *Unregulated* DC Supply with the LTC694-3.3/LTC695-3.3's Power-Fail Comparator

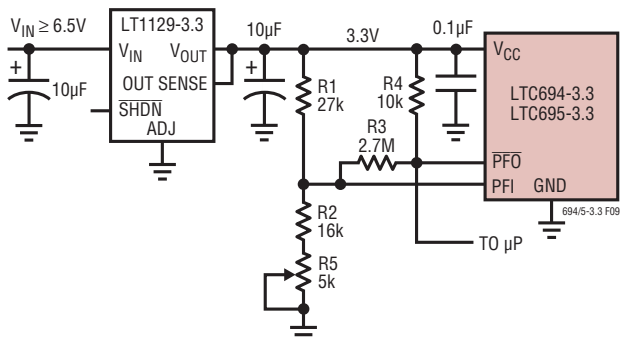

Figure 9. Monitoring *Regulated* DC Supply with the LTC694-3.3/LTC695-3.3's Power-Fail Comparator

\overline{CE} IN can be derived from the microprocessor's address decoder output. Figure 6 shows a typical nonvolatile CMOS RAM application.

Memory protection can also be achieved with the LTC694-3.3 by using \overline{RESET} as shown in Figure 7.

Power-Fail Warning

The LTC694-3.3/LTC695-3.3 generate a Power Failure Output (PFO) for early warning of failure in the microprocessor's power supply. This is accomplished by comparing the power failure input (PFI) with an internal 1.3V reference.

PFO goes low when the voltage at the PFI pin is less than 1.3V. Typically PFI is driven by an external voltage divider (R1 and R2 in Figures 8 and 9) which senses either an unregulated DC input or a regulated 3.3V output. The voltage divider ratio can be chosen such that the voltage at the PFI pin falls below 1.3V several milliseconds before the 3.3V supply falls below the maximum reset voltage threshold 3.0V. PFO is normally used to interrupt the microprocessor to execute shutdown procedure between \overline{PFO} and \overline{RESET} or RESET.

The power-fail comparator, C3, does not have hysteresis. Hysteresis can be added however, by connecting a resistor between the PFO output and the noninverting PFI input pin as shown in Figures 8 and 9. The upper and lower trip points in the comparator are established as follows:

When PFO output is low, R3 sinks current from the summing junction at the PFI pin.

$$V_H = 1.3V \left(1 + \frac{R1}{R2} + \frac{R1}{R3} \right)$$

When PFO output is high, the series combination of R3 and R4 source current into the PFI summing junction.

$$V_L = 1.3V \left(1 + \frac{R1}{R2} - \frac{(3.3V \pm 1.3V)R1}{1.3V(R3 + R4)} \right)$$

$$\text{Assuming } R4 \ll R3, V_{HYSTERESIS} = 3.3V \frac{R1}{R3}$$

LTC694-3.3/LTC695-3.3

APPLICATIONS INFORMATION

Example 1: The circuit in Figure 8 demonstrates the use of the power-fail comparator to monitor the unregulated power supply input. Assuming the the rate of decay of the supply input V_{IN} is 100mV/ms and the total time to execute a shutdown procedure is 8ms. Also the noise of V_{IN} is 200mV. With these assumptions in mind, we can reasonably set $V_L = 5V$ which is 1.6V greater than the sum of maximum reset voltage threshold and the dropout voltage of the LT1129-3.3 ($3V + 0.4V$) and $V_{HYSTERESIS} = 850mV$.

$$V_{HYSTERESIS} = 3.3V \frac{R1}{R3} = 850mV$$

$$R3 \approx 3.88 R1$$

Choose $R3 = 200k$ and $R1 = 51k$. Also select $R4 = 10k$ which is much smaller than $R3$.

$$5V = 1.3V \left(1 - \frac{51k}{R2} - \frac{(3.3V - 1.3V)51k}{1.3V(210k)} \right)$$

$R2 = 15.8k$, Choose nearest 5% resistor 16k and recalculate V_L ,

$$V_L = 1.3V \left(1 + \frac{51k}{16k} - \frac{(3.3V - 1.3V)51k}{1.3V(210k)} \right) = 4.96V$$

$$V_H = 1.3V \left(1 + \frac{51k}{16k} + \frac{51k}{200k} \right) = 5.77V$$

$$\frac{(4.96V - 3.4V)}{100mV/ms} = 15.6ms$$

$$V_{HYSTERESIS} = 5.77V - 4.96V = 810mV$$

The 15.6ms allows enough time to execute shutdown procedure for microprocessor and 810mV of hysteresis would prevent \overline{PFO} from going low due to the noise of V_{IN} .

Example 2: The circuit in Figure 9 can be used to measure the regulated 3.3V supply to provide early warning of power failure. Because of variations in the PFI threshold, this circuit requires adjustment to ensure the PFI comparator trips before the reset threshold is reached. Adjust $R5$ such that the \overline{PFO} output goes low when the V_{CC} supply reaches the desired level (e.g., 3.1V).

Monitoring the Status of the Battery

C3 can also monitor the status of the memory back-up battery (Figure 10). If desired, the \overline{CE} OUT can be used to apply a test load to the battery. Since \overline{CE} OUT is forced high in battery back-up mode, the test load will not be applied to the battery while it is in use, even if the microprocessor is not powered.

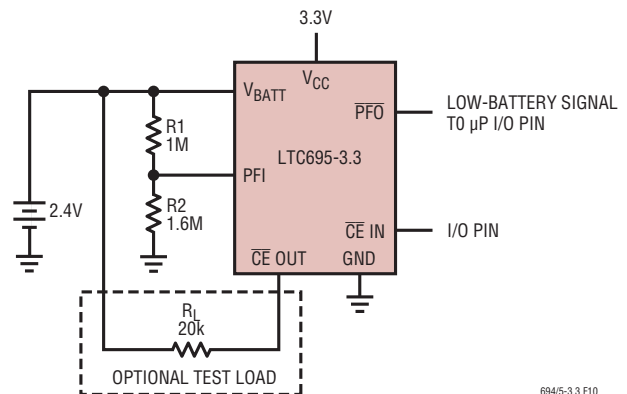

Figure 10. Back-Up Battery Monitor with Optional Test Load

Watchdog Timer

The LTC694-3.3/LTC695-3.3 provide a watchdog timer function to monitor the activity of the microprocessor. If the microprocessor does not toggle the watchdog input (WDI) within a selected timeout period, \overline{RESET} is forced to active low for a minimum of 140ms. The reset active time is adjustable on the LTC695-3.3. Since many systems can not service the watchdog timer immediately after a reset, the LTC695-3.3 has a longer timeout period (1.0 second minimum) right after a reset is issued. The normal timeout period (70ms minimum) becomes effective following the first transition of WDI after \overline{RESET} is inactive. The watchdog timeout period is fixed at 1.0 second minimum on the LTC694-3.3. Figure 11 shows the timing diagram of watchdog timeout period and reset active time. The watchdog timeout period is restarted as soon as \overline{RESET} is inactive. When either a high-to-low or low-to-high transition occurs at the WDI pin prior to timeout, the watchdog time is reset and begins to time out again. To ensure the watchdog time does not time out, either a high-to-low or low-to-high transition on the WDI pin must occur at or less than the minimum timeout period. If the input to the

LTC694-3.3/LTC695-3.3

APPLICATIONS INFORMATION

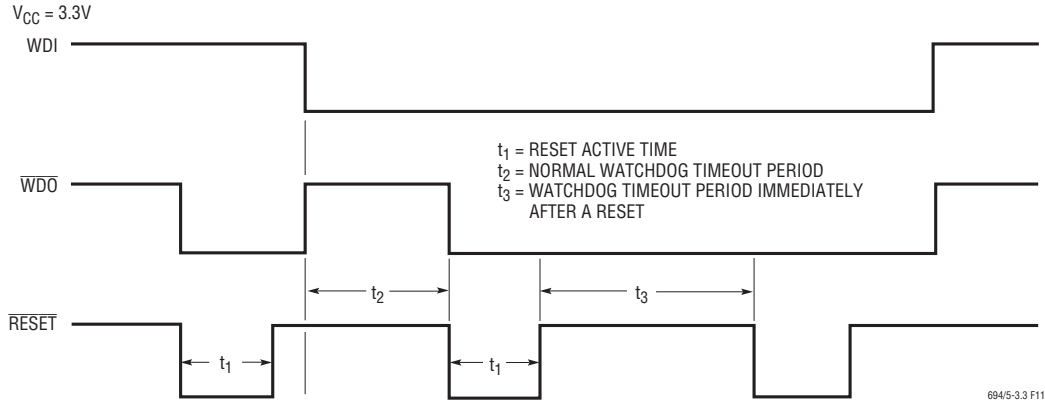

Figure 11. Watchdog Timeout Period and Reset Active Time

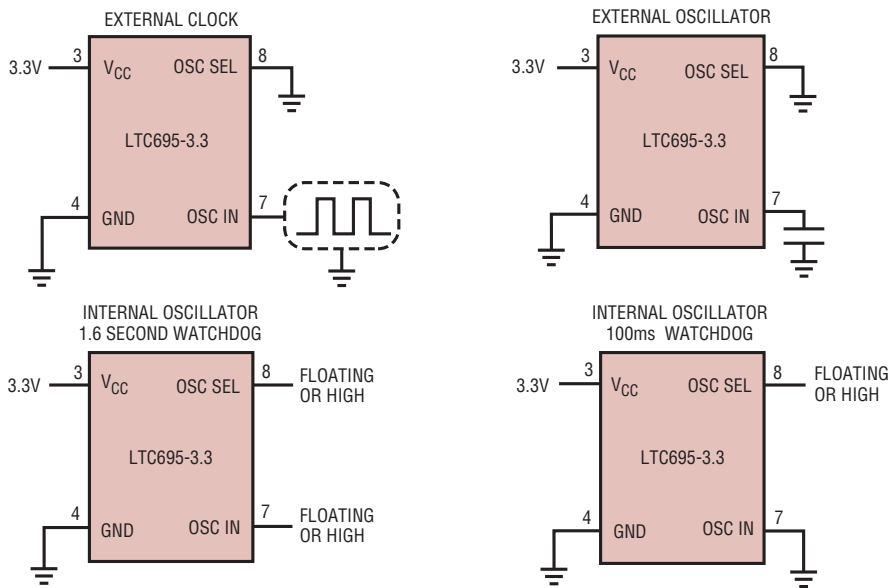

Figure 12. Oscillator Configurations

WDI pin remains either high or low, reset pulses will be issued every 1.6 seconds typically. The watchdog time can be deactivated by floating the WDI pin. The timer is also disabled when V_{CC} falls below the reset voltage threshold or V_{BATT} .

The LTC695-3.3 provides an additional output (Watchdog Output, \overline{WDO}) which goes low if the watchdog timer is allowed to time out and remains low until set high by the next transition on the WDI pin. \overline{WDO} is also set high when V_{CC} falls below the reset voltage threshold or V_{BATT} .

The LTC695-3.3 has two additional pins, OSC SEL and OSC IN, which allow reset active time and watchdog timeout period to be adjusted per Table 2. Several configurations are shown in Figure 12.

OSC IN can be driven by an external clock signal and an external capacitor can be connected between OSC IN and GND when OSC SEL is forced low. In these configurations, the nominal reset active time and watchdog timeout period are determined by the number of clocks or set by the formula in Table 2. When OSC SEL is high or floating,

LTC694-3.3/LTC695-3.3

TYPICAL APPLICATION

Table 2. LTC695-3.3 Reset Active Time and Watchdog Timeout Selections

OSC SEL	OSC IN	WATCHDOG TIMEOUT PERIOD		RESET ACTIVE TIME
		NORMAL (SHORT PERIOD)	IMMEDIATELY AFTER RESET (LONG PERIOD)	LTC695-3.3
Low	External Clock Input	1024 CLKs	4096 CLKs	2048 CLKs
Low	External Capacitor*	$\frac{400\text{ms}}{70\text{pF}} \cdot C$	$\frac{1.6\text{s}}{70\text{pF}} \cdot C$	$\frac{800\text{ms}}{70\text{pF}} \cdot C$
Floating or High	Low	100ms	1.6 sec	200ms
Floating or High	Floating or High	1.6 sec	1.6 sec	200ms

*The nominal internal frequency is 10.24kHz. The nominal oscillator frequency with external capacitor is $f_{\text{OSC}} (\text{Hz}) = \frac{184,000}{C(\text{pF}) \cdot 1025}$

the internal oscillator is enabled and the reset active time is fixed at 140ms minimum for the LTC695-3.3. OSC IN selects between the 1 second and 70ms minimum normal watchdog timeout periods. In both cases, the timeout period immediately after a reset is at least 1 second.

Push-Button Reset

The LTC694-3.3/LTC695-3.3 do not provide a logic input for direct connection to a push-button. However, a push-button in series with a 100Ω resistor connected to the $\overline{\text{RESET}}$ output pin (Figure 13) provides an alternative for manual reset. Connecting a 0.1μF capacitor to the $\overline{\text{RESET}}$ pin debounces the push-button input.

The 100Ω resistor in series with the push-button is required to prevent the ringing, due to the capacitance and lead inductance, from pulling the $\overline{\text{RESET}}$ pins of the MPU and LTC69X below ground.

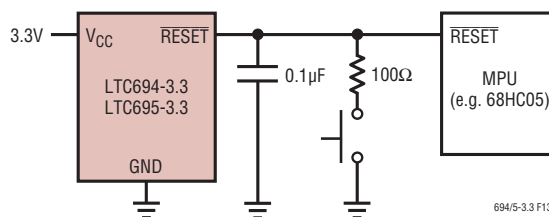
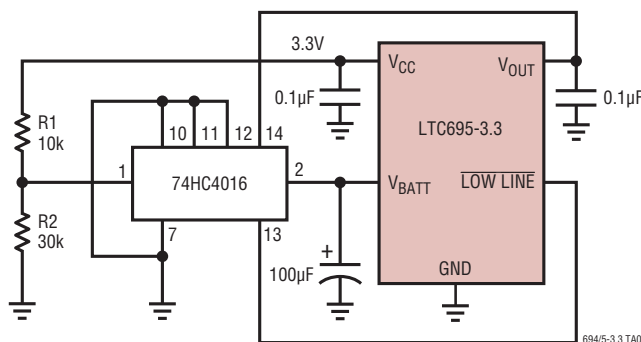

Figure 13. The External Push-Button Reset

TYPICAL APPLICATION

Capacitor Back-Up with 74HC4016 Switch



LTC694-3.3/LTC695-3.3

PACKAGE DESCRIPTION

N8 Package 8-Lead PDIP (Narrow 0.300) (Reference LTC DWG # 05-08-1510)

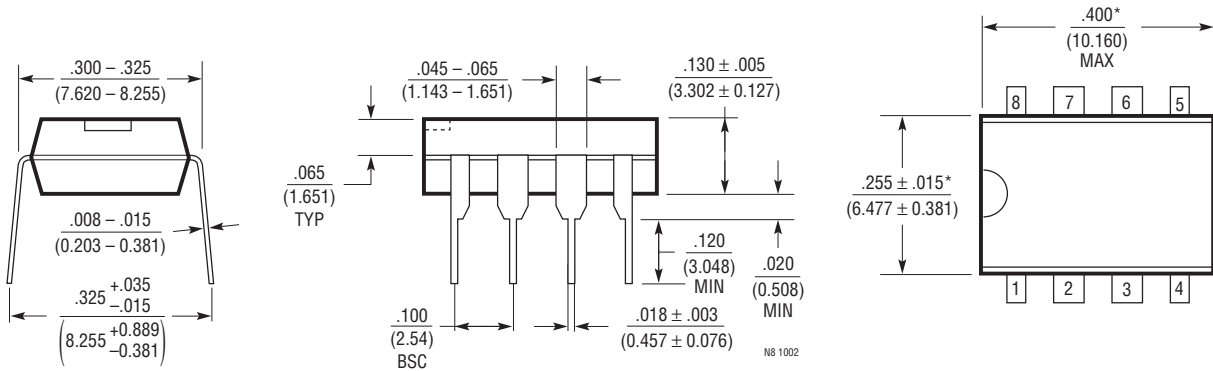

NOTE:
 1. DIMENSIONS ARE $\frac{\text{INCHES}}{\text{MILLIMETERS}}$
 *THESE DIMENSIONS DO NOT INCLUDE MOLD FLASH OR PROTRUSIONS.
 MOLD FLASH OR PROTRUSIONS SHALL NOT EXCEED .010 INCH (0.254mm)

S8 Package 8-Lead Plastic Small Outline (Narrow 0.150) (Reference LTC DWG # 05-08-1610)

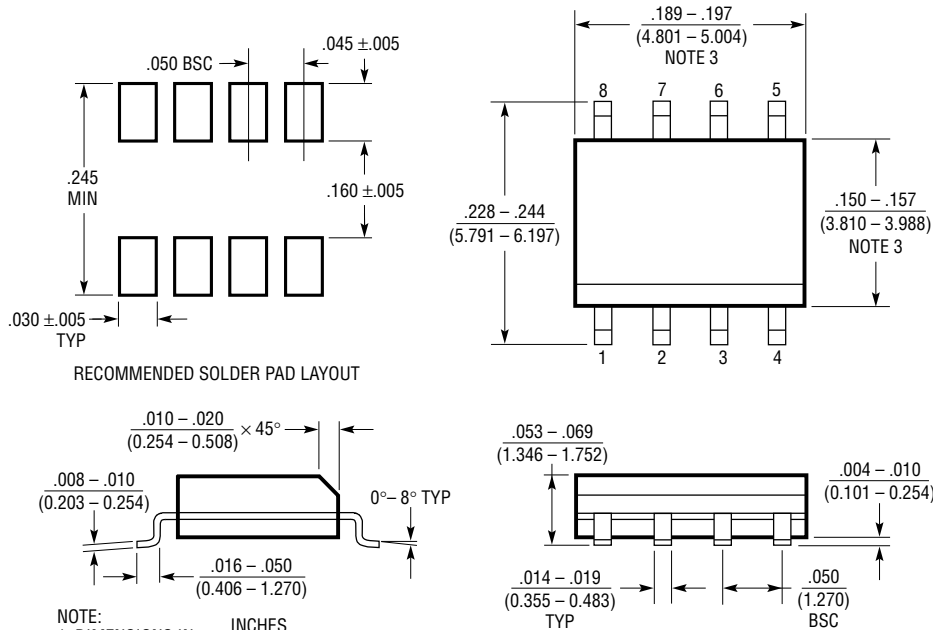

NOTE:
 1. DIMENSIONS IN $\frac{\text{INCHES}}{\text{MILLIMETERS}}$
 2. DRAWING NOT TO SCALE
 3. THESE DIMENSIONS DO NOT INCLUDE MOLD FLASH OR PROTRUSIONS.
 MOLD FLASH OR PROTRUSIONS SHALL NOT EXCEED .006" (0.15mm)

S08 0303

LTC694-3.3/LTC695-3.3

PACKAGE DESCRIPTION

N Package
16-Lead PDIP (Narrow 0.300)
 (Reference LTC DWG # 05-08-1510)

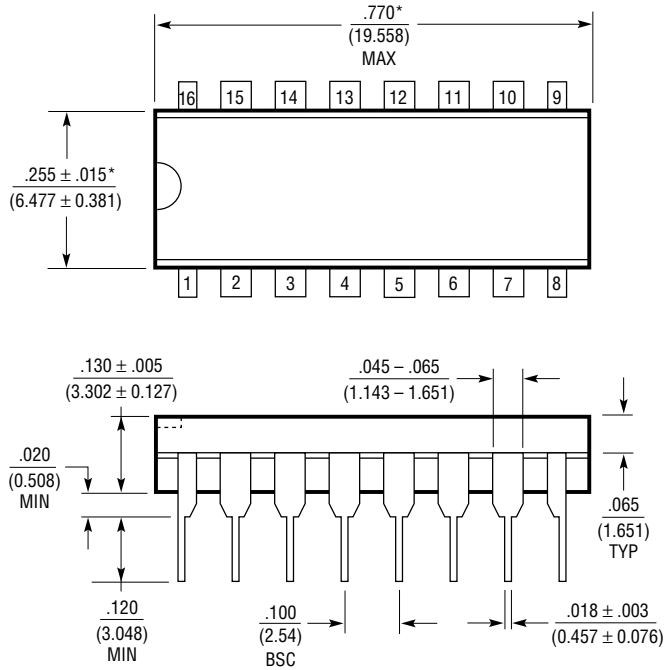

NOTE:
 1. DIMENSIONS ARE $\frac{\text{INCHES}}{\text{MILLIMETERS}}$
 *THESE DIMENSIONS DO NOT INCLUDE MOLD FLASH OR PROTRUSIONS.
 MOLD FLASH OR PROTRUSIONS SHALL NOT EXCEED .010 INCH (0.254mm)

N161002

LTC694-3.3/LTC695-3.3

PACKAGE DESCRIPTION

SW Package
16-Lead Plastic Small Outline (Wide 0.300)
 (Reference LTC DWG # 05-08-1620)

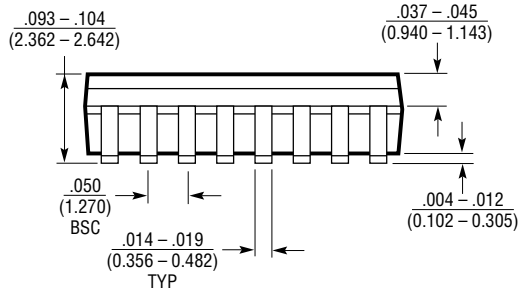
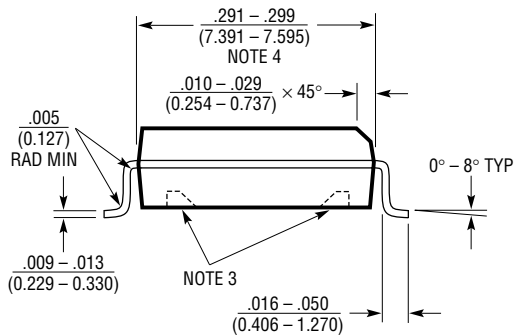
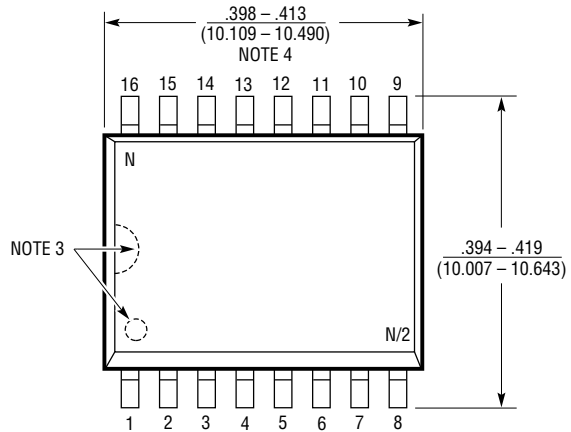
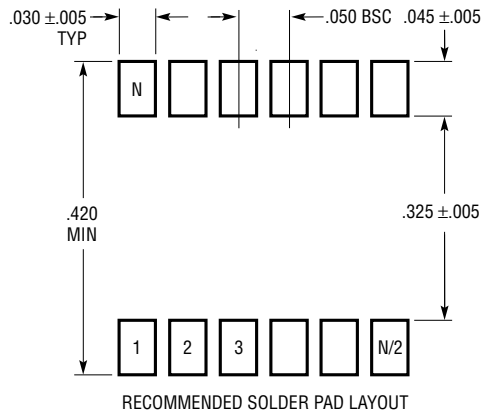

- NOTE:
 1. DIMENSIONS IN $\frac{\text{INCHES}}{\text{MILLIMETERS}}$
 2. DRAWING NOT TO SCALE
 3. PIN 1 IDENT, NOTCH ON TOP AND CAVITIES ON THE BOTTOM OF PACKAGES ARE THE MANUFACTURING OPTIONS. THE PART MAY BE SUPPLIED WITH OR WITHOUT ANY OF THE OPTIONS
 4. THESE DIMENSIONS DO NOT INCLUDE MOLD FLASH OR PROTRUSIONS. MOLD FLASH OR PROTRUSIONS SHALL NOT EXCEED .006" (0.15mm)

S16 (WIDE) 0502

LTC694-3.3/LTC695-3.3

REVISION HISTORY (Revision history begins at Rev B)

REV	DATE	DESCRIPTION	PAGE NUMBER
B	3/10	Removed "UL Recognized" and UL file number from the Features section.	1

LTC694-3.3/LTC695-3.3

TYPICAL APPLICATION

Write Protect for Additional RAMs

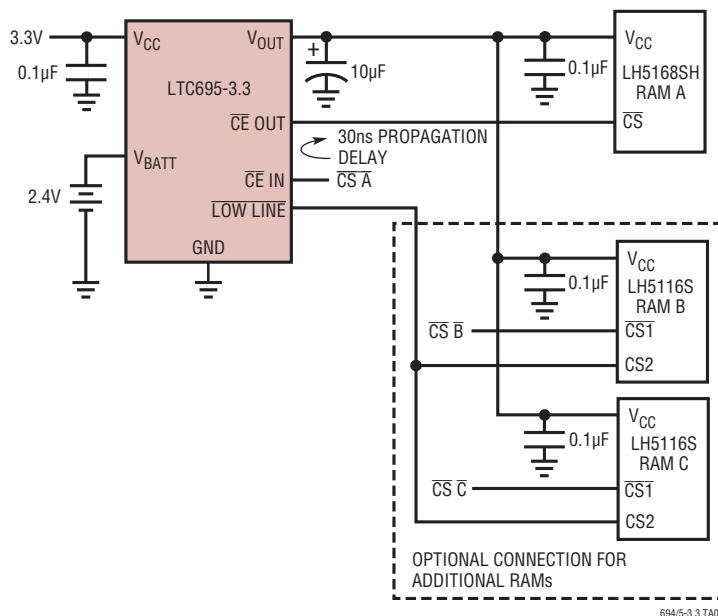

RELATED PARTS

PART NUMBER	DESCRIPTION	COMMENTS
LTC1326	Micropower Precision Triple Supply Monitor	4.725V, 3.118V, 1V Thresholds (0.75%)
LTC1536	Micropower Triple Supply Monitor for PCI Applications	Meets PCI t_{FAIL} Timing Specifications