

Excellent Integrated System Limited

Stocking Distributor

Click to view price, real time Inventory, Delivery & Lifecycle Information:

[TE Connectivity AMP Connectors](#)
[206062-1](#)

For any questions, you can email us directly:

sales@integrated-circuit.com

THIS DRAWING IS UNPUBLISHED.		RELEASED FOR PUBLICATION		LOC	DIST	REVISIONS					
COPYRIGHT BY TYCO ELECTRONICS CORPORATION.		ALL INTERNATIONAL RIGHTS RESERVED.				P	LTR	DESCRIPTION	DATE	OWN	APVD
						U3		REVISED PER ECO-10-012730	20SEP10	HMR	MG

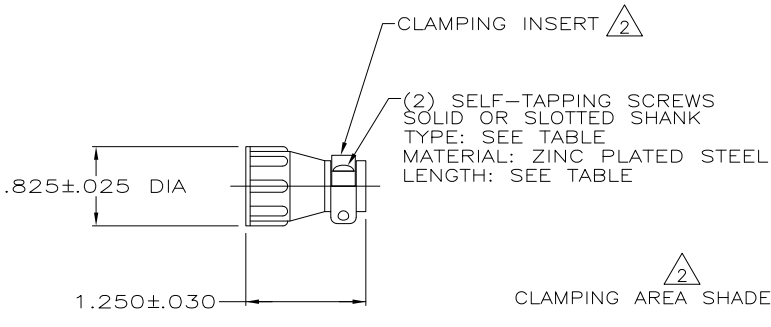

- 1 PARTS PACKAGED UNASSEMBLED.
- 2 CABLE CLAMPING AREA ADJUSTABLE FROM .004 TO .055 SQ IN BY REVERSING CLAMPING INSERTS.
- 3 .329 MAXIMUM CABLE OUTSIDE DIAMETER.
- 4 BULK PACKAGED KITS TO BE ORDERED IN MULTIPLES OF 400 ONLY.
- 5 OBSOLETE PART NUMBER.
- 6 STAINLESS STEEL (NON MAGNETIC).
- 7 CABLE CLAMP WITH NON-MAGNETIC STAINLESS STEEL SCREWS.
- 8 ZINC PLATED STEEL, NON-HEXAVALENT CHROMATE.
- 9 OBSOLETE PARTS: OBSOLETE CIS STREAMLINING PER D.RENAUD/D.SINISI

4	BULK	6	.50±.005	#5-20	1-206062-7
	INDIVIDUAL	8	.38±.005	#5-20	1-206062-6
4	BULK	8	.38±.005	#5-20	1-206062-5
	INDIVIDUAL	8	.50±.005	#5-20	1-206062-4
	INDIVIDUAL	8	.62±.005	#5-20	1-206062-3
	INDIVIDUAL	6	.50±.005	#5-20	1-206062-2
SUPERSEDED BY 1-206062-3	INDIVIDUAL	8	.62±.005	#5-20	1-206062-1
9 OBSOLETE	SMALL PACK	8	.38±.005	#5-20	1-206062-0
AMP BRAZIL USE ONLY	INDIVIDUAL		12mm±.8	3mm-20	206062-9
AMP BRAZIL USE ONLY	INDIVIDUAL		10mm±.8	3mm-20	206062-8
SUPERSEDED BY 1-206062-7	4 BULK	6	.50±.005	#5-20	206062-4
SUPERSEDED BY 1-206062-4	INDIVIDUAL	8	.50±.005	#5-20	206062-3
SUPERSEDED BY 1-206062-5	4 BULK	8	.38±.005	#5-20	206062-2
SUPERSEDED BY 1-206062-6	INDIVIDUAL	8	.38±.005	#5-20	206062-1

PACKAGING	SCREW FINISH	SCREW LENGTH	SCREW TYPE	PART NUMBER
THIS DRAWING IS A CONTROLLED DOCUMENT.				
DIMENSIONS: INCHES		TOLERANCES UNLESS OTHERWISE SPECIFIED:		
		0 PLC ± - 1 PLC ± - 2 PLC ± - 3 PLC ± - 4 PLC ± - ANGLES ± -		
MATERIAL: THERMOPLASTIC		FINISH: -		
DWN: A GRAFF 4/29/91		CHK: W.G.LENKER 7-22-92		
APVD: -		NAME: Tyco Electronics Corporation Harrisburg, PA 17105-3608		
PRODUCT SPEC: -		APPLICATION SPEC: -		
WEIGHT: -		SIZE: A3 CAGE CODE: 00779 DRAWING NO: C=206062		
CUSTOMER DRAWING		SCALE: NTS SHEET: 1 of 1 REV: U3		