



Distributor of Texas Instruments: Excellent Integrated System Limited

Datasheet of PT7743N - REG SW 5VIN 20A I-BOOST VERT T/H

Contact us: sales@integrated-circuit.com Website: www.integrated-circuit.com

Excellent Integrated System Limited

Stocking Distributor

Click to view price, real time Inventory, Delivery & Lifecycle Information:

[Texas Instruments](#)

[PT7743N](#)

For any questions, you can email us directly:

sales@integrated-circuit.com

PT7743—5.0V

20 Amp "Current Booster" for PT7709
Integrated Switching Regulator

Power Trends Products
from Texas Instruments

SLTS086

(Revised 6/30/2000)

Description

The PT7743 is a 20 Amp "Current Booster" for the PT7709 housed in the same 27-pin SIP package.

Multiple PT7743 boosters will operate in parallel with one PT7709 product, boosting output current in increments of 20A. Combinations of a PT7709 regulator and PT7743 current boosters can supply power for virtually any multiple mega-processor application.

A PT7743 current booster adds a

parallel output stage that is driven directly by the regulator. This allows the system to run in perfect synchronization to provide a low noise solution.

The PT7743 only operates in combination with a PT7709 series regulator, and is not a stand-alone product. Please refer to the PT7709 data sheet for the performance specifications.

The booster uses the same 27-pin case and has the same package options as its companion regulator.

Pin-Out Information

Pin	Function	Pin	Function
1	Do not connect	14	GND
2	Do not connect	15	GND
3	Do not connect	16	GND
4	Do not connect	17	GND
5	Do not connect	18	GND
6	Do not connect	19	GND
7	V _{in}	20	V _{out}
8	V _{in}	21	V _{out}
9	V _{in}	22	V _{out}
10	V _{in}	23	V _{out}
11	V _{in}	24	V _{out}
12	Do not connect	25	V _{out}
13	GND	26	Do not connect
		27	Master Sync In

Ordering Information

PT7743□

(For dimensions and PC Board layout, see Package Styles 800 and 810.)

PT Series Suffix (PT1234X)

Case/Pin Configuration

Vertical Through-Hole	N
Horizontal Through-Hole	A
Horizontal Surface Mount	C

Features

- 20A Current Boost
- Tracks V_o of a PT7709
- High Efficiency
- Input Voltage Range: 4.5V to 5.5V
- Synchronized with PT7709
- 27-pin SIP Package
- Connect up to 2 in Parallel for 60 Amps

Standard Application

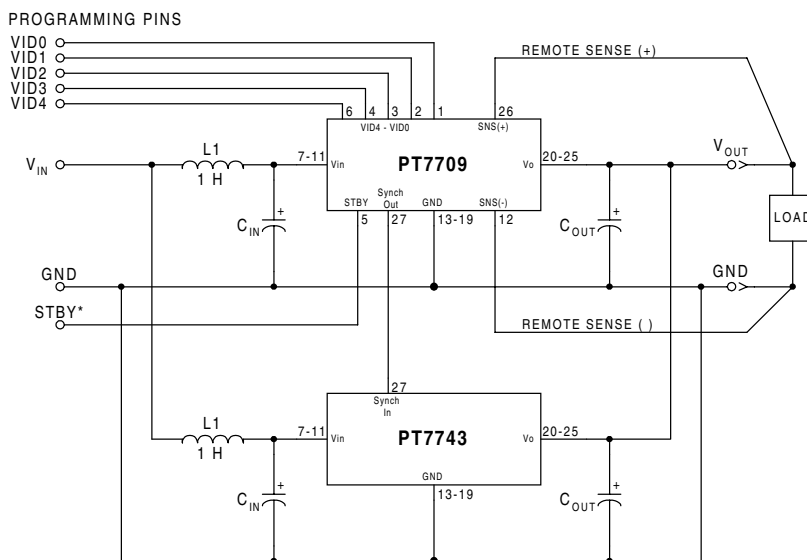

External Capacitors: The PT7743 requires a minimum output capacitance of 330µF for proper operation. The PT7743 also requires an input capacitance of 1500µF, which must be rated for a minimum of 1.4Arms of ripple current. For transient or dynamic load applications additional capacitance may be required. For further information refer to the application note regarding capacitor selection for this product.

Input Filter: An input filter inductor is optional for most applications. The inductor must be sized to handle 20ADC with a typical value of 1µH.

Application Notes



PT7708/PT7709, PT7742/PT7743

Capacitor Recommendations for the PT7708/09 Regulators and PT7742/43 Current Boosters

Input Capacitors

The recommended input capacitance is determined by 1.4 ampere minimum ripple current rating and 1500 μ F minimum capacitance. Capacitors listed below must be rated for a minimum of 2x the input voltage with +5V operation. Ripple current and $\leq 100\text{m}\Omega$ Equivalent Series Resistance (ESR) values are the major considerations along with temperature when selecting the proper capacitor.

Output Capacitors

The minimum required output capacitance is 330 μ F with a maximum ESR less than or equal to 100m Ω . Failure to observe this requirement may lead to regulator instability or oscillation. Electrolytic capacitors have poor ripple performance at frequencies greater than 400kHz, but excellent low frequency transient response. Above the ripple frequency ceramic decoupling capacitors are necessary to improve the transient response and reduce any microprocessor high frequency noise components apparent during higher current excursions. Preferred low ESR type capacitor part numbers are identified in the Table 1 below.

Tantalum Characteristics

Tantalum capacitors with a minimum 10V rating are recommended on the output bus, but only the AVX TPS Series, Sprague 594/595 Series, or Kemet T495/T510 Series. The AVX TPS Series, Sprague Series or Kemet Series capacitors are specified over other types due to their higher surge current, excellent power dissipation and ripple current ratings. As an example, the TAJ Series by AVX is not recommended. This series exhibits considerably higher ESR, reduced power dissipation and lower ripple current capability. The TAJ Series is a less reliable compared to the TPS series when determining power dissipation capability.

Capacitor Table

Table 1 identifies the characteristics of capacitors from a number of vendors with acceptable ESR and ripple current (rms) ratings. The suggested minimum quantities per regulator for both the input and output buses are identified.

This is not an extensive capacitor list. The table below is a selection guide for input and output capacitors. Other capacitor vendors are available with comparable RMS ripple current rating and ESR (Equivalent Series Resistance at 100kHz). These critical parameters are necessary to insure both optimum regulator performance and long capacitor life.

Table 1 Capacitors Characteristic Data

Capacitor Vendor/ Series	Capacitor Characteristics					Quantity		Vendor Number
	Working Voltage	Value(μ F)	(ESR) Equivalent Series Resistance	105°C Maximum Ripple Current(Irms)	Physical Size(mm)	Input Bus	Output Bus	
Panasonic FC Surface Mtg FA	16V	2200	0.038 Ω	2000mA	18x16.5	1	1	EEVFC1C222N EEVFC1V331LQ
	35V	330	0.065 Ω	1205mA	12.5x16.5			
United Chemi -Con LFB Series	10V	680	0.090 Ω	755mA	10x12.5	1	1	EEUFA1A681 EEUFA1C182A
	16V	1800	0.032 Ω	2000mA	18x15			
United Chemi -Con LFB Series	25V	330	0.084 Ω	825mA	10x16	1	1	LXV25VB331M10X16LL LXV16VB222M16X20LL LXV16VB471M10X16LL
	16V	2200	0.038 Ω	1630mA	16x20			
	16V	470	0.084 $\Omega/2=0.042\Omega$	825mA x2	10x16			
Nichicon PL Series PM Series	10V	680	0.090 Ω	770mA	10x15	1	1	UPL1A681MHH6 UPL1A182MHH6 UPL1E331MPH6
	10V	1800	0.044 Ω	1420mA	16x15			
	25V	330	0.095 Ω	750mA	10x15			
Oscon SS SV	10V	330	0.025W/4=0.006 Ω	>9800mA	10x10.5	4	N/R (Note)	10SS330M 10SV330M(Sufvace Mtg)
	10V	330	0.020/4=0.005 Ω	>9800mA	10.3x12.6			
AVX Tanatalum TPS- Series	10V	330	0.100/5=20 Ω	3500mA	7.3Lx	5	1	TPSV337M010R0100 TPSV337M010R0060
	10V	330	0.060 Ω	1826mA	4.3Wx 4.1H			
Sprague Tantalum 595D/594D	10V	330	0.045W/4=0.011 Ω	>4500mA	7.3L x 5.7W x	5	1	594D337X0010R2T Surface Mount 595D687X0010R2T
	10V	680	0.090 Ω	>1660mA	4.0H			
Kemet Tantalum T510/T495 Series	10V	330	0.035 Ω	2000mA	4.3Wx7.3L x4.0H	5	1	510X337M010AS Surface Mount
	10V	220	0.070 $\Omega/2=0.035\Omega$	>2000mA				
Sanyo Poscap TPB	10V	220	0.040 Ω	3000mA	7.2L x 4.3W x 3.1H	6	2	10TPB220M Surface Mount

Note: (N/R) is not recommended for this application, due to extremely low Equivalent Series Resistance (ESR)



PACKAGING INFORMATION

Orderable Device	Status ⁽¹⁾	Package Type	Package Drawing	Pins	Package Qty	Eco Plan ⁽²⁾	Lead/Ball Finish	MSL Peak Temp ⁽³⁾	Samples (Requires Login)
PT7743A	NRND	SIP MODULE	EHA	27		TBD	Call TI	Call TI	Samples Not Available
PT7743C	NRND	SIP MODULE	EHC	27		TBD	Call TI	Call TI	Samples Not Available

⁽¹⁾ The marketing status values are defined as follows:

ACTIVE: Product device recommended for new designs.

LIFEBUY: TI has announced that the device will be discontinued, and a lifetime-buy period is in effect.

NRND: Not recommended for new designs. Device is in production to support existing customers, but TI does not recommend using this part in a new design.

PREVIEW: Device has been announced but is not in production. Samples may or may not be available.

OBSOLETE: TI has discontinued the production of the device.

⁽²⁾ Eco Plan - The planned eco-friendly classification: Pb-Free (RoHS), Pb-Free (RoHS Exempt), or Green (RoHS & no Sb/Br) - please check <http://www.ti.com/productcontent> for the latest availability information and additional product content details.

TBD: The Pb-Free/Green conversion plan has not been defined.

Pb-Free (RoHS): TI's terms "Lead-Free" or "Pb-Free" mean semiconductor products that are compatible with the current RoHS requirements for all 6 substances, including the requirement that lead not exceed 0.1% by weight in homogeneous materials. Where designed to be soldered at high temperatures, TI Pb-Free products are suitable for use in specified lead-free processes.

Pb-Free (RoHS Exempt): This component has a RoHS exemption for either 1) lead-based flip-chip solder bumps used between the die and package, or 2) lead-based die adhesive used between the die and leadframe. The component is otherwise considered Pb-Free (RoHS compatible) as defined above.

Green (RoHS & no Sb/Br): TI defines "Green" to mean Pb-Free (RoHS compatible), and free of Bromine (Br) and Antimony (Sb) based flame retardants (Br or Sb do not exceed 0.1% by weight in homogeneous material)

⁽³⁾ MSL, Peak Temp. -- The Moisture Sensitivity Level rating according to the JEDEC industry standard classifications, and peak solder temperature.

Important Information and Disclaimer:The information provided on this page represents TI's knowledge and belief as of the date that it is provided. TI bases its knowledge and belief on information provided by third parties, and makes no representation or warranty as to the accuracy of such information. Efforts are underway to better integrate information from third parties. TI has taken and continues to take reasonable steps to provide representative and accurate information but may not have conducted destructive testing or chemical analysis on incoming materials and chemicals. TI and TI suppliers consider certain information to be proprietary, and thus CAS numbers and other limited information may not be available for release.

In no event shall TI's liability arising out of such information exceed the total purchase price of the TI part(s) at issue in this document sold by TI to Customer on an annual basis.

IMPORTANT NOTICE

Texas Instruments Incorporated and its subsidiaries (TI) reserve the right to make corrections, modifications, enhancements, improvements, and other changes to its products and services at any time and to discontinue any product or service without notice. Customers should obtain the latest relevant information before placing orders and should verify that such information is current and complete. All products are sold subject to TI's terms and conditions of sale supplied at the time of order acknowledgment.

TI warrants performance of its hardware products to the specifications applicable at the time of sale in accordance with TI's standard warranty. Testing and other quality control techniques are used to the extent TI deems necessary to support this warranty. Except where mandated by government requirements, testing of all parameters of each product is not necessarily performed.

TI assumes no liability for applications assistance or customer product design. Customers are responsible for their products and applications using TI components. To minimize the risks associated with customer products and applications, customers should provide adequate design and operating safeguards.

TI does not warrant or represent that any license, either express or implied, is granted under any TI patent right, copyright, mask work right, or other TI intellectual property right relating to any combination, machine, or process in which TI products or services are used. Information published by TI regarding third-party products or services does not constitute a license from TI to use such products or services or a warranty or endorsement thereof. Use of such information may require a license from a third party under the patents or other intellectual property of the third party, or a license from TI under the patents or other intellectual property of TI.

Reproduction of TI information in TI data books or data sheets is permissible only if reproduction is without alteration and is accompanied by all associated warranties, conditions, limitations, and notices. Reproduction of this information with alteration is an unfair and deceptive business practice. TI is not responsible or liable for such altered documentation. Information of third parties may be subject to additional restrictions.

Resale of TI products or services with statements different from or beyond the parameters stated by TI for that product or service voids all express and any implied warranties for the associated TI product or service and is an unfair and deceptive business practice. TI is not responsible or liable for any such statements.

TI products are not authorized for use in safety-critical applications (such as life support) where a failure of the TI product would reasonably be expected to cause severe personal injury or death, unless officers of the parties have executed an agreement specifically governing such use. Buyers represent that they have all necessary expertise in the safety and regulatory ramifications of their applications, and acknowledge and agree that they are solely responsible for all legal, regulatory and safety-related requirements concerning their products and any use of TI products in such safety-critical applications, notwithstanding any applications-related information or support that may be provided by TI. Further, Buyers must fully indemnify TI and its representatives against any damages arising out of the use of TI products in such safety-critical applications.

TI products are neither designed nor intended for use in military/aerospace applications or environments unless the TI products are specifically designated by TI as military-grade or "enhanced plastic." Only products designated by TI as military-grade meet military specifications. Buyers acknowledge and agree that any such use of TI products which TI has not designated as military-grade is solely at the Buyer's risk, and that they are solely responsible for compliance with all legal and regulatory requirements in connection with such use.

TI products are neither designed nor intended for use in automotive applications or environments unless the specific TI products are designated by TI as compliant with ISO/TS 16949 requirements. Buyers acknowledge and agree that, if they use any non-designated products in automotive applications, TI will not be responsible for any failure to meet such requirements.

Following are URLs where you can obtain information on other Texas Instruments products and application solutions:

Products		Applications	
Amplifiers	amplifier.ti.com	Audio	www.ti.com/audio
Data Converters	dataconverter.ti.com	Automotive	www.ti.com/automotive
DLP® Products	www.dlp.com	Communications and Telecom	www.ti.com/communications
DSP	dsp.ti.com	Computers and Peripherals	www.ti.com/computers
Clocks and Timers	www.ti.com/clocks	Consumer Electronics	www.ti.com/consumer-apps
Interface	interface.ti.com	Energy	www.ti.com/energy
Logic	logic.ti.com	Industrial	www.ti.com/industrial
Power Mgmt	power.ti.com	Medical	www.ti.com/medical
Microcontrollers	microcontroller.ti.com	Security	www.ti.com/security
RFID	www.ti-rfid.com	Space, Avionics & Defense	www.ti.com/space-avionics-defense
RF/IF and ZigBee® Solutions	www.ti.com/lprf	Video and Imaging	www.ti.com/video
		Wireless	www.ti.com/wireless-apps