

Excellent Integrated System Limited

Stocking Distributor

Click to view price, real time Inventory, Delivery & Lifecycle Information:

[NXP Semiconductors](#)

[MC44BC380EFR2](#)

For any questions, you can email us directly:

sales@integrated-circuit.com

Technical Data

MC44BC380/D
Rev. 1.3 09/2002

MC44BC380
VHF/ UHF ANTENNA
BOOSTER/SPLITTER
IC

MC44BC380

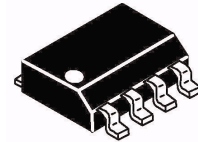

SO8 Package

Ordering Information

Device	Temp. Range	Package
MC44BC380D, R2	-20°C to +85°C	SO8NB
NOTE: For tape and reel, add R@ suffix.		

1 Features 2
 2 Functional Description 3
 3 Maximum Ratings 3
 4 Antenna/Booster Splitter Electrical Characteristics 4
 5 IC Block Diagram 6
 6 Diagrams 7

This modulator circuit is for use in VCRs, set top boxes, and similar devices.

Figure 1 shows the pin connections.

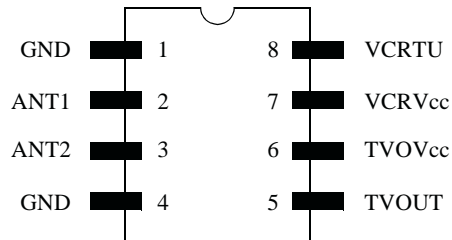

Figure 1. Pin Connections

This document contains information on a product under development. Freescale reserves the right to change or discontinue this product without notice. © Motorola, Inc., 2002. All rights reserved.

1 Features

This circuit is developed using Motorola RF BiCMOS technology. With a transmit frequency of 18GHz, the Antenna Booster/Splitter allows high RF performance at low cost.

The Antenna Booster/Splitter function boosts the antenna signal, then splits it into two (2) 75 Ohm outputs for the TV and auxiliary outputs. Main applications are for:

- Set-Top Box (STB)
- VCR tuner
- PIP TV
- Video games

RF output of the STB or VCR is added to the boosted received antenna signal.

The MC44BC380 has the following features:

- Frequency operation range (40MHz to 880MHz)
- Extremely low external component count
- Low power consumption (35 mA typical)
- Balanced inputs for low distortion
- Balanced amplifiers for maximum isolation

2 Functional Description

Figure 2 is a simplified block diagram, which shows the basic circuit functionality.

The MC44BC380 has separate Vccs and a maximum grounding pattern to ensure high performance in terms of isolation and leakage.

The MC44BC380 comes in an SO8 package and has a minimum pin count, which reduces cost and application board space.

NOTE:

A BALUN is required at the input to achieve the stated performance.

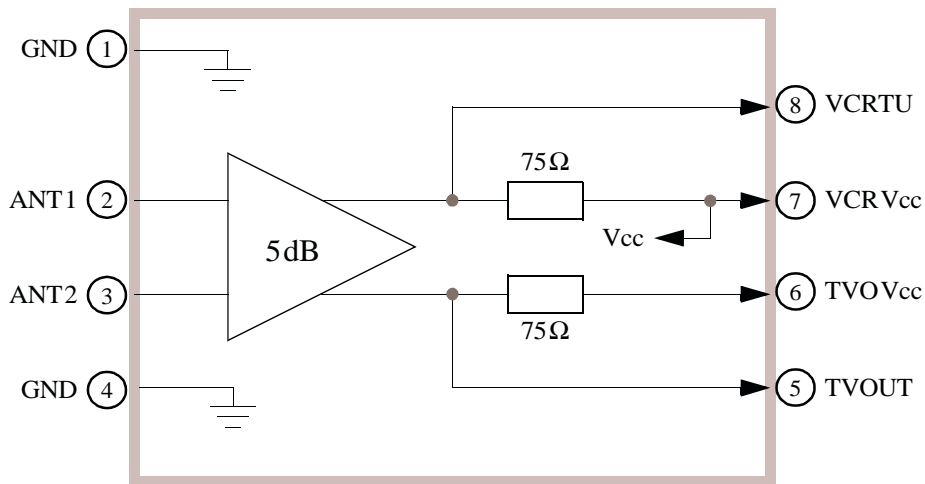

Figure 2. Simplified Block Diagram—MC44BC380

3 Maximum Ratings

Sym	Parameter	Value	Unit
Vcc1	Supply voltage	6	V
Tamin	Minimum operating ambient temperature	-10	°C
Tamax	Maximum operating ambient temperature	75	°C
Tstgmin	Minimum storage temperature	-65	°C
Tstgmax	Maximum storage temperature	150	°C

This device contains protection circuitry to guard against damage due to high static voltage or electric fields. However, precautions must be taken to avoid applications of any voltage higher than maximum rated voltages to this high impedance circuit. For proper operation, input and output voltages should be constrained to the ranges indicated in the Recommended Operating Conditions.

Maximum ratings are those values beyond which damage to the device may occur. For functional operation, voltage should be restricted to the Recommended Operating Condition.

4 Antenna/Booster Splitter Electrical Characteristics

4.1 Parameter Type

A:	100% Tested	C:	Characterized on samples
B:	100% Correlation tested	D:	Design parameter

4.2 Specification Conditions

Unless otherwise stated: $V_{CC}=5.0V$, Ambient Temperature= $25^{\circ}C$, all outputs into 75 Ohm load. All specifications use a BALUN at ANT1, 2 inputs, assuming a 0.8dB MAX loss from 40MHz to 880MHz.

Table 1. Specification Conditions

Ref	Parameter	Test Conditional	Min	Typ	Max	Unit	Type
Vcc	Supply Voltage		4.5	5	5.5	V	
IccB	BST section supply current		28	35	42	mA	
	Frequency range		40		880	MHz	
GvGt	Gain	ANT1, 2 to VCRTU ANT1, 2 to TVOUT		5 5		dB	
	Gain Flatness	40 to 880MHz	-1.2		+1.2	dB	
	Noise figure	ANT1, 2 to VCRTU and ANT1, 2 to TVOUT		7	9.5	dB	
	VSWR	All pins, BST bias ON At TVout and VCRTU, BST bias OFF		1.5	2	—	
		At ANTin pins. BST OFF.		2.5	3	—	
	Intermodulation (IMD)	Input level=90dBuV See IMD Measurement	45			dBc	
	Isolation	From TVOUT or VCR to ANT1, 2 TVOUT/VCRTU from 40MHz to 600MHz ¹	45 30	50 45		dBc	

- Output-to-Output isolation is dependant on printed circuit board (PCB) layout and Vcc line DC-coupling. See Application records and PCB layout proposal.

4.3 Intermodulation (IMD) Measurement

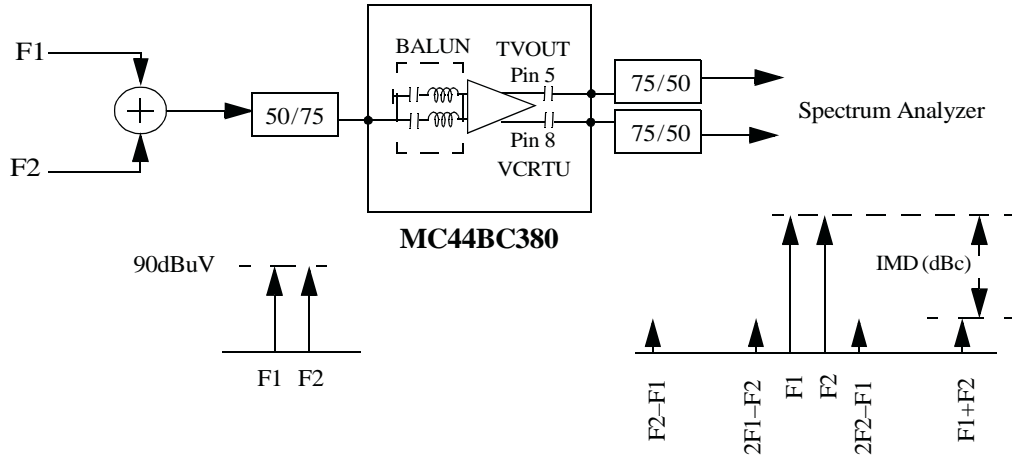

Intermodulation frequencies are all frequency combinations coming from the two input carriers F1 and F2: $F2-F1$, $2 * F1-F2$, $2 * F2-F1$ and $F1+F2$, falling into the 40Mhz to 900Mhz range.

Intermodulation (IMD) measurement is the difference (in dBc) between F1 or F2 level at the Output (VCRTU or TVOUT) and spurious level, for all the following cases:

- | | | |
|-------------------------|-------------------------|-------------------------|
| F1=50Mhz and F2=60Mhz | F1=100Mhz and F2=110Mhz | F1=200Mhz and F2=210Mhz |
| F1=300Mhz and F2=310Mhz | F1=400Mhz and F2=410Mhz | F1=500Mhz and F2=510Mhz |
| F1=600Mhz and F2=610Mhz | F1=700Mhz and F2=710Mhz | F1=800Mhz and F2=810Mhz |

F1 and F2 input levels are set to 90dBuV. Spurious specification is the worst case IMD measurement.

5 IC Block Diagram

5.1 Proposed Booster/Splitter Schematic

This document contains information on a new product under development.
 Motorola reserves the right to change or discontinue this product without notice.

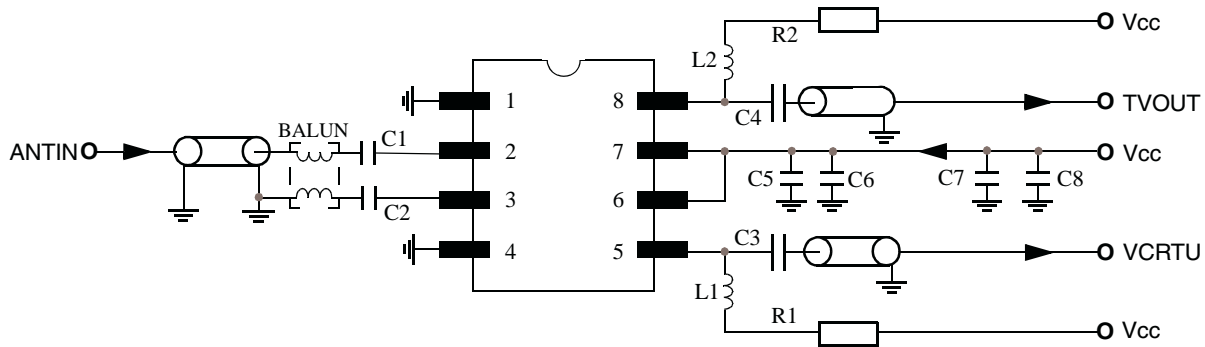

Figure 3. Proposed Booster/Splitter Schematic

5.1.1 Components

- 1nF Capacitors: C1, C2, C3, C4, C5, C6, C8
- 10nF Capacitor: C7
- Application dependant: L1, L2, R1, R2

5.1.2 Recommendations

- A BALUN is required for this application
- A single-sided PCB has been used to evaluate the device performance.
- Decoupling capacitors C5 and C6 decrease coupling between TVOUT and VCRTU through the Vcc line (bonding and PCB coupling) and increase TVOUT to VCRTU isolation (see proposed PCB layout).
- Pull-ups to Vcc may be needed on TVOUT and VCRTU pins to improve spurious performance at low Vcc (1uH in series with 75Ω).
- Resistive pull-ups can also be used to decrease gain and increase spurious performance. For example, 267Ohms reduces gain by about 1 dB and increases IMD value by 2 to 6dB. Trade-off depends on application requirements.

6 Diagrams

6.1 Proposed Single-Sided PCB Layout

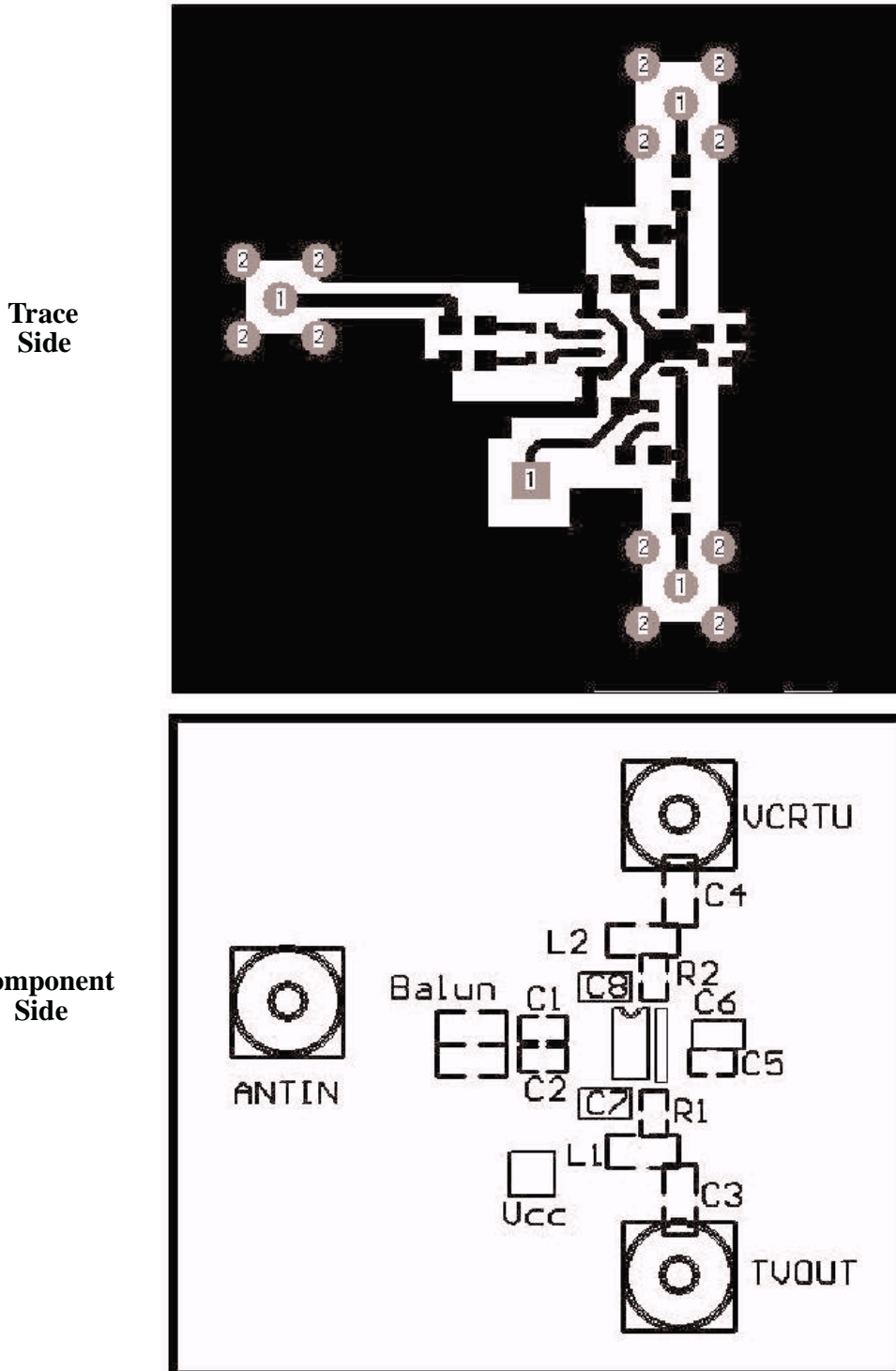
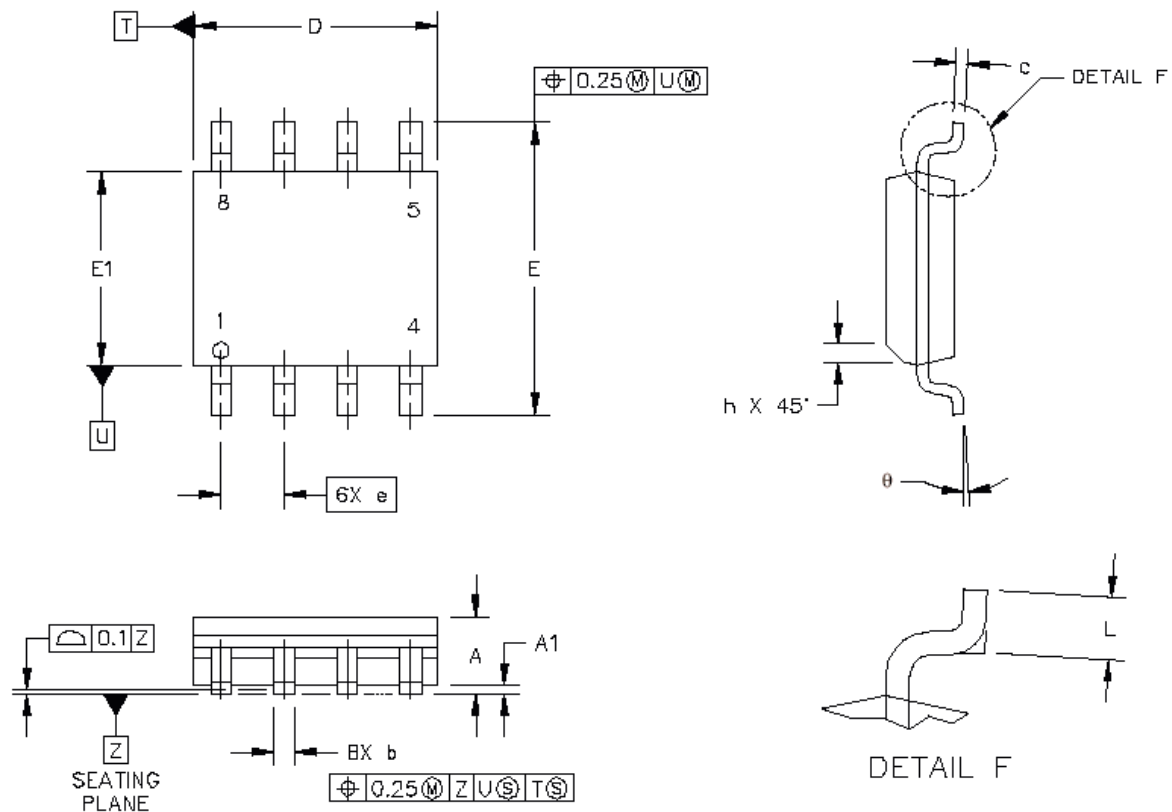

Figure 4. Proposed Single-Sided PCB Layout



LD Narrow Body—150 MIL PKG—1.27 Pitch POD

Dim	Millimeters		Inches	
	Min	Max	Min	Max
A	1.35	1.75	0.053	0.069
A1	0.1	0.25	0.003	0.010
D	4.8	5	0.188	0.197
E	5.8	6.2	0.228	0.244
E1	3.8	4	0.149	0.157
b	0.35	0.49	0.013	0.019
c	0.19	0.25	0.007	0.010
e	1.27 BSC		0.050 BSC	
h	0.25	0.5	0.009	0.020
L	0.4	1.25	0.015	0.049
Q	0°	7°	0°	7°

NOTE:

1. Dimensioning and Tolerancing per ANSI Y14.5M, 1994.
2. Controlling dimension: Millimeters.
3. Dimensions D and E1 do not include mold protrusions.
4. Maximum mold protrusion is 0.15 (0.006) per side.
5. Dimension b does not include Dambar protrusion. Allowable Dambar protrusion shall be 0.127 total in excess of b dimension at maximum material condition.

Figure 5. Diagram—SO8 Package



Distributor of NXP Semiconductors: Excellent Integrated System Limited

Datasheet of MC44BC380EFR2 - IC BOOSTER/SPLITTER ANT 8-SOIC

Contact us: sales@integrated-circuit.com Website: www.integrated-circuit.com

Freescale Semiconductor, Inc.

Diagrams

Freescale Semiconductor, Inc.

MC44BC380 Technical Data
**For More Information On This Product,
Go to: www.freescale.com**



Distributor of NXP Semiconductors: Excellent Integrated System Limited

Datasheet of MC44BC380EFR2 - IC BOOSTER/SPLITTER ANT 8-SOIC

Contact us: sales@integrated-circuit.com Website: www.integrated-circuit.com

Freescale Semiconductor, Inc.

Freescale Semiconductor, Inc.

MC44BC380/D

**For More Information On This Product,
Go to: www.freescale.com**