

Excellent Integrated System Limited

Stocking Distributor

Click to view price, real time Inventory, Delivery & Lifecycle Information:

[TT Electronics/Optek Technology](#)
[OPF2418](#)

For any questions, you can email us directly:

sales@integrated-circuit.com

Fiber Optic Receiver

OPF2418, OPF2418T, OPF2418TC



OPF2418 Family

- Up to 194 Mbps operation
- 850nm wavelength
- ST[®] style port
- Wave solderable
- Wide temperature range

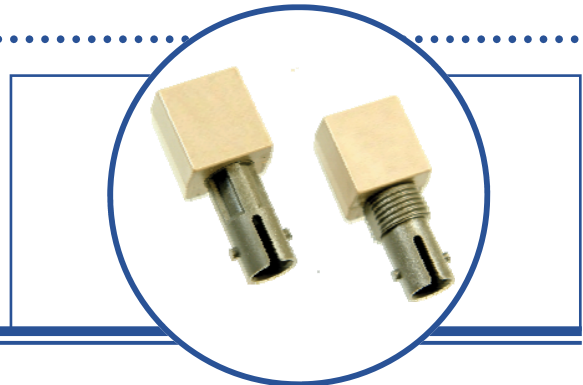

The OPF2418 family is a low cost solution for high speed fiber optic communications designs. The internal lensing of this receiver's design allows optimal response for fiber sizes of 100µm and below. The receiver is comprised of a high speed, low noise, photodiode coupled to a transimpedance amplifier (TIA). The photodiode/TIA combination produces an output voltage that is proportional to the input light amplitude. This hybrid approach solves many of the problems of high speed data link designs by placing the photodiode close to the TIA. The amplification of the TIA makes the output much less susceptible to EMI. The output of the OPF2418 is an analog, low impedance, emitter follower voltage source. Subsequent circuitry can be utilized to convert the analog voltage to ECL/TTL for digital data rates up to 155 Mbps. The OPF2418 is available with either standard or threaded panel mount ST[®] receptacles. The threaded version is also available in conductive plastic.

Applications

- ◆ Industrial Ethernet equipment
- ◆ Copper-to-fiber media conversion
- ◆ Intra-system fiber optic links
- ◆ Video surveillance systems

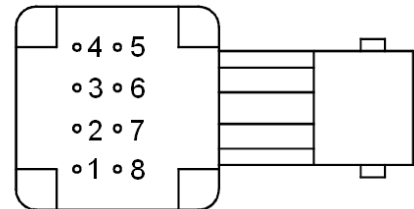
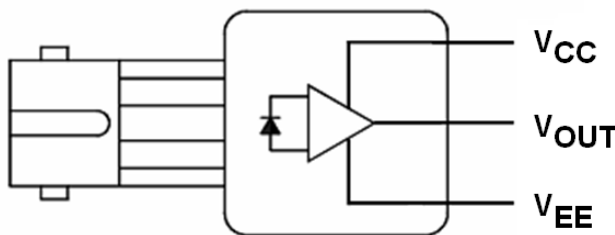

PIN	FUNCTION
1	Not Connected
2	V _{OUT}
3	V _{EE}
4	Not Connected
5	Not Connected
6	V _{CC}
7	V _{EE}
8	Not Connected

"T" suffix = Threaded ST[®] package
 "TC" suffix = Threaded, conductive ST[®] package



RoHS



ESD Class 2

Pins 3 & 7 are electrically connected to the header.
 Pins 1,4,5 & 8 are mechanically connected together.

ST[®] is a registered trademark of AT&T.

OPTEK reserves the right to make changes at any time in order to improve design and to supply the best product possible.

Fiber Optic Receiver

OPF2418, OPF2418T, OPF2418TC



Absolute Maximum Ratings

T_A = 25° C unless otherwise noted

Storage Temperature Range	-55° C to +85° C
Operating Temperature Range	-40° C to +85° C
Lead Soldering Temperature ⁽¹⁾	260° C
Supply Voltage	-0.5 V to 6.0 V
Output Current	25 mA
Output Pin Voltage	-0.5 V

Electrical/Optical Characteristics (T_A = 25° C unless otherwise noted)

SYMBOL	PARAMETER	MIN	TYP	MAX	UNITS	CONDITIONS
R	Responsivity	5.3 4.5	7.0	9.6 11.5	mV/μW	λ _p = 850 nm, f = 50 MHz -40 °C ≤ T _A ≤ +85 °C
V _{NOISE}	RMS Output Noise Voltage		0.40	0.59 0.70	mV	75 MHz Bandwidth Filtered, P _R = 0 Unfiltered Bandwidth Filtered P _R = 0
P _N	RMS Equivalent Optical Noise Input Power		0.050	0.065	μW	100 MHz Bandwidth Filtered, P _R = 0
P _R	Peak Received Optical Power			175 150	μW	40 °C ≤ T _A ≤ +85 °C
V _{ODC}	DC Output Voltage	-4.2	-3.1	-2.4	V	P _R = 0
I _{EE}	Supply Current		9	15	mA	R _L = ∞
BW	Bandwidth	155	200		MHz	-3dB electrical
t _r , t _f	Rise Time, Fall Time		2.0	2.6	ns	f = 50 MHz, P _R = 100 μW peak, R _L = 511 Ω, C _{LOAD} = 5 pF
PWD	Pulse Width Distortion		0.4	2.5	ns	f = 50 MHz, P _R = 150 μW peak
PSRR	Power Supply Rejection Ratio		20		dB	f = 10 MHz

Notes:

- Maximum of 5 seconds with soldering iron. Duration can be extended to 10 seconds when flow soldering. RMA flux is recommended.

Application Circuit

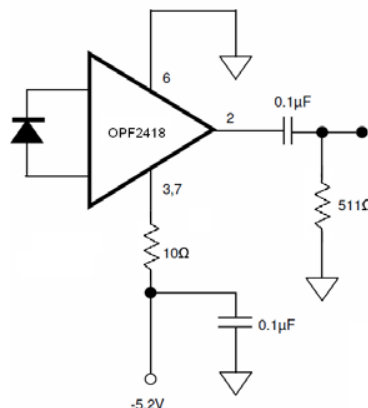

Note that the 10Ω resistor and bypass capacitor are

OPTEK reserves the right to make changes at any time in order to improve design and to supply the best product possible.

Fiber Optic Receiver

OPF2418, OPF2418T, OPF2418TC



Mechanical Data

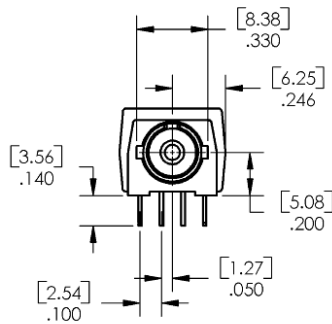
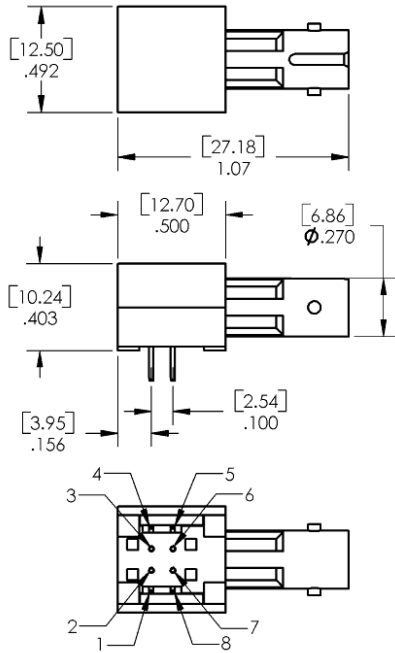

OPF2418

PINS 1, 4, 5, & 8 - .020 X .015
[0.51 X 0.38]
 PINS 2, 3, 6, & 7 - Ø.018
[0.46]

OPF2418T
OPF2418TC

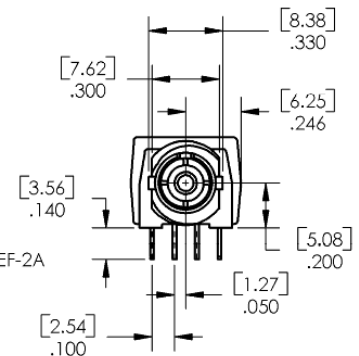
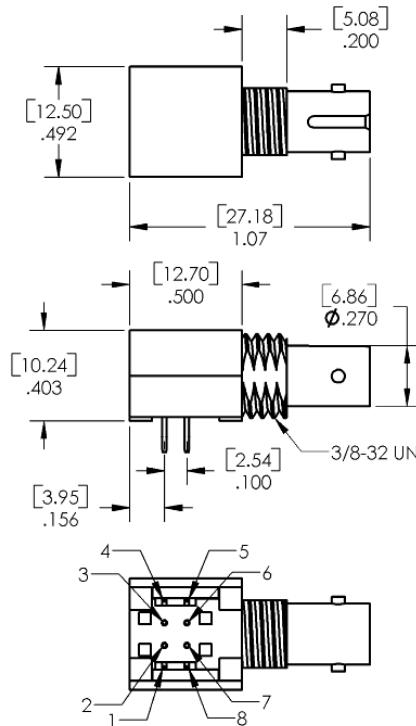

PINS 1, 4, 5, & 8 - .020 X .015
[0.51 X 0.38]
 PINS 2, 3, 6, & 7 - Ø.018
[0.46]

DIMENSIONS ARE IN INCHES [MILLIMETERS]

OPTEK reserves the right to make changes at any time in order to improve design and to supply the best product possible.