

Excellent Integrated System Limited

Stocking Distributor

Click to view price, real time Inventory, Delivery & Lifecycle Information:

[IXYS Corporation](#)

[CS20-22MOF1](#)

For any questions, you can email us directly:

sales@integrated-circuit.com

High Voltage Phase Control Thyristor in High Voltage ISOPLUS i4-PAC™

$$\begin{aligned} V_{DRM} = V_{RRM} &= 2200 \text{ V} \\ I_{T(AV)} &= 18 \text{ A} \\ I_{TSM} &= 200 \text{ A} \end{aligned}$$

V_{RSM} V_{DSM} V	V_{RRM} V_{DRM} V	Type
2300	2200	CS 20-22moF1

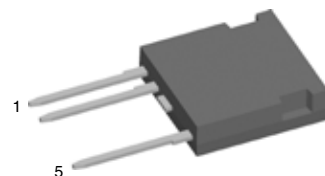
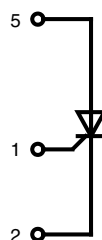

Thyristor					
Symbol	Conditions	Maximum Ratings			
$V_{DRM / RRM}$		2200	V		
$I_{T(AV)}$	sine 180°; $T_C = 90^\circ\text{C}$	18	A		
$I_{T(AV)}$	square; $d = 1/3$; $T_C = 90^\circ\text{C}$	16	A		
I_{TSM}	sine 180°; $t = 10 \text{ ms}$; $V_R = 0 \text{ V}$; $T_{VJ} = 25^\circ\text{C}$	200	A		
$(di/dt)_{cr}$	$T_{VJ} = T_{VJM}$ $f = 50 \text{ Hz}$; $t_p = 200 \mu\text{s}$	repetitive, $I_T = 40 \text{ A}$	100	$\text{A}/\mu\text{s}$	
	$V_D = 2/3 V_{DRM}$ $I_G = 0.45 \text{ A}$ $di_G/dt = 0.45 \text{ A}/\mu\text{s}$	non repetitive, $I_T = 20 \text{ A}$	250	$\text{A}/\mu\text{s}$	
$(dv/dt)_{cr}$	$T_{VJ} = T_{VJM}$; $V_D = 2/3 V_{DRM}$ $R_{GK} = \infty$; method 1 (linear voltage rise)		2500	$\text{V}/\mu\text{s}$	
Symbol		Conditions	Characteristic Values ($T_{VJ} = 25^\circ\text{C}$, unless otherwise specified)		
			typ.	max.	
V_T	$I_T = 20 \text{ A}$;	$T_{VJ} = 25^\circ\text{C}$ $T_{VJ} = 125^\circ\text{C}$	1.3 1.3	1.5	V
V_{GT}	$V_D = 6 \text{ V}$			2.3	V
I_{GT}				250	mA
V_{GD}	$V_D = 2/3 V_{DRM}$;	$T_{VJ} = T_{VJM}$		0.2	V
I_{GD}				5	mA
I_L	$t_p = 10 \mu\text{s}$; $V_D = 6 \text{ V}$ $I_G = 0.45 \text{ A}$; $di_G/dt = 0.45 \text{ A}/\mu\text{s}$			500	mA
I_H	$V_D = 6 \text{ V}$; $R_{GK} = \infty$			150	mA
t_{gd}	$V_D = 1/2 V_{DRM}$ $I_G = 0.45 \text{ A}$; $di_G/dt = 0.45 \text{ A}/\mu\text{s}$			2	μs
I_R, I_D	$V_R = V_{RRM}$; $V_D = V_{DRM}$;	$T_{VJ} = 25^\circ\text{C}$ $T_{VJ} = 125^\circ\text{C}$	2	50	μA mA
R_{thJC}	DC current			0.92	K/W

Features

- high voltage thyristor
 - for line frequency
 - chip technology for long term stability
- ISOPLUS i4-PAC™ high voltage package
 - isolated back surface
 - enlarged creepage towards heatsink
 - enlarged creepage between high voltage pins
 - application friendly pinout
 - high reliability
 - industry standard outline

Applications

- controlled rectifiers
 - power supplies
 - drives
- AC switches
- capacitor discharge control
 - flash tubes
 - X-ray and laser generators

Component			
Symbol	Conditions	Maximum Ratings	
T_{VJ}		-40 ... +125	°C
T_{stg}		-55 ... +125	°C
V_{ISOL}	$I_{ISOL} \leq 1 \text{ mA}; 50/60 \text{ Hz}$	2500	V~
F_C	mounting force with clip	20...120	N

Symbol	Conditions	Characteristic Values	
		min.	typ.
d_s, d_A	A pin - K pin	7	mm
	pin - backside metal	5.5	mm
R_{thCH}	with heatsink compound		0.15 K/W
Weight			5.5 g

Dimensions in mm (1 mm = 0.0394")

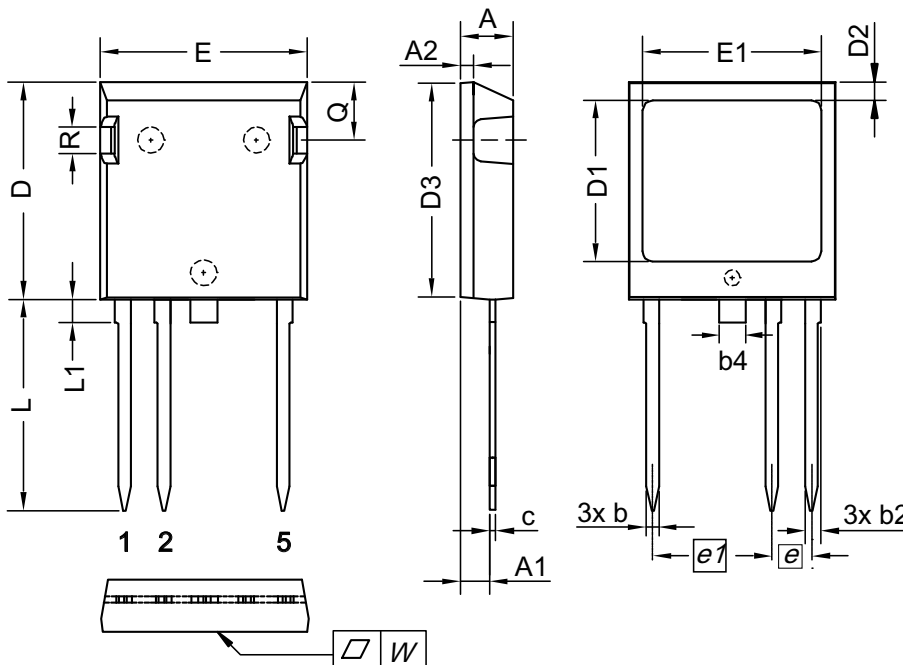

Dim.	Millimeter		Inches	
	min	max	min	max
A	4.83	5.21	0.190	0.205
A1	2.59	3.00	0.102	0.118
A2	1.17	2.16	0.046	0.085
b	1.14	1.40	0.045	0.055
b2	1.47	1.73	0.058	0.068
b4	2.54	2.79	0.100	0.110
c	0.51	0.74	0.020	0.029
D	20.80	21.34	0.819	0.840
D1	14.99	15.75	0.590	0.620
D2	1.65	2.03	0.065	0.080
D3	20.30	20.70	0.799	0.815
E	19.56	20.29	0.770	0.799
E1	16.76	17.53	0.660	0.690
e	3.81 BSC		0.150 BSC	
e1	11.43 BSC		0.450 BSC	
L	19.81	21.34	0.780	0.840
L1	2.11	2.59	0.083	0.102
Q	5.33	6.20	0.210	0.244
R	2.54	4.57	0.100	0.180
W	-	0.10	-	0.004

Die konvexe Form des Substrates ist typ. < 0.05 mm über der Kunststoffoberfläche der Bauteilunterseite
The convex bow of substrate is typ. < 0.05 mm over plastic surface level of device bottom side