

Excellent Integrated System Limited

Stocking Distributor

Click to view price, real time Inventory, Delivery & Lifecycle Information:

[IXYS Corporation](#)

[MDD220-08N1](#)

For any questions, you can email us directly:

sales@integrated-circuit.com

High Power Diode Modules

$$I_{FRSM} = 2x 450 A$$

$$I_{FAVM} = 2x 270 A$$

$$V_{RRM} = 1200-1800 V$$

V_{RSM} V	V_{RRM} V	Type
1300	1200	MDD 220-12N1
1500	1400	MDD 220-14N1
1700	1600	MDD 220-16N1
1900	1800	MDD 220-18N1

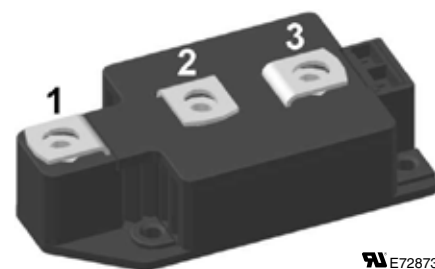
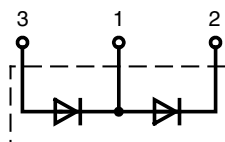

E72873

Symbol	Conditions	Maximum Ratings	
I_{FRMS}	$T_{VJ} = T_{VJM}$	450	A
I_{FAVM}	$T_C = 100^{\circ}C$; 180° sine	270	A
I_{FSM}	$T_{VJ} = 45^{\circ}C$; $t = 10$ ms (50 Hz) $V_R = 0$ $t = 8.3$ ms (60 Hz)	8500	A
		9000	A
	$T_{VJ} = T_{VJM}$; $t = 10$ ms (50 Hz) $V_R = 0$ $t = 8.3$ ms (60 Hz)	7500	A
		8000	A
I^2t	$T_{VJ} = 45^{\circ}C$; $t = 10$ ms (50 Hz) $V_R = 0$ $t = 8.3$ ms (60 Hz)	360000	A ² s
		340000	A ² s
	$T_{VJ} = T_{VJM}$; $t = 10$ ms (50 Hz) $V_R = 0$ $t = 8.3$ ms (60 Hz)	280000	A ² s
		260000	A ² s
T_{VJ}		-40...+150	°C
T_{VJM}		150	°C
T_{stg}		-40...+125	°C
V_{ISOL}	50/60 Hz, RMS $t = 1$ min $I_{ISOL} \leq 1$ mA $t = 1$ s	3000	V~
		3600	V~
M_d	Mounting torque (M5) Terminal connection torque (M8)	2.5 - 5	Nm
		12 - 15	Nm
Weight	Typical including screws	320	g

Features

- Direct copper bonded Al_2O_3 ceramic base plate
- Planar passivated chips
- Isolation voltage 3600 V~
- UL registered, E 72873

Applications

- Supplies for DC power equipment
- DC supply for PWM inverter
- Field supply for DC motors
- Battery DC power supplies

Advantages

- Space and weight savings
- Simple mounting
- Improved temperature and power cycling
- Reduced protection circuits

Symbol	Conditions	Characteristics Values	
I_{RRM}	$V_R = V_{RRM}$; $T_{VJ} = T_{VJM}$	40	mA
V_F	$I_F = 600$ A; $T_{VJ} = 25^{\circ}C$	1.4	V
V_{T0}	For power-loss calculations only	0.75	V
r_t	$T_{VJ} = T_{VJM}$	0.9	mΩ
R_{thJC}	per diode; DC current	0.129	K/W
	per module <i>other values</i>	0.065	K/W
R_{thJK}	per diode; DC current <i>see Fig. 6/7</i>	0.169	K/W
	per module	0.0845	K/W
Q_S	$T_{VJ} = 125^{\circ}C$; $I_F = 400$ A; $-di/dt = 50$ A/μs	760	μC
I_{RM}		275	A
d_s	Creeping distance on surface	12.7	mm
d_A	Creepage distance in air	9.6	mm
a	Maximum allowable acceleration	50	m/s ²

Data according to IEC 60747 and refer to a single diode unless otherwise stated.

IXYS **MDD 220**

Dimensions in mm (1 mm = 0.0394")

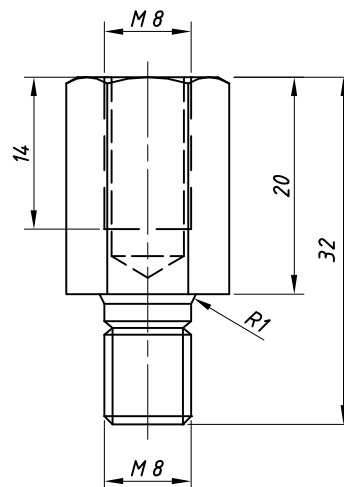
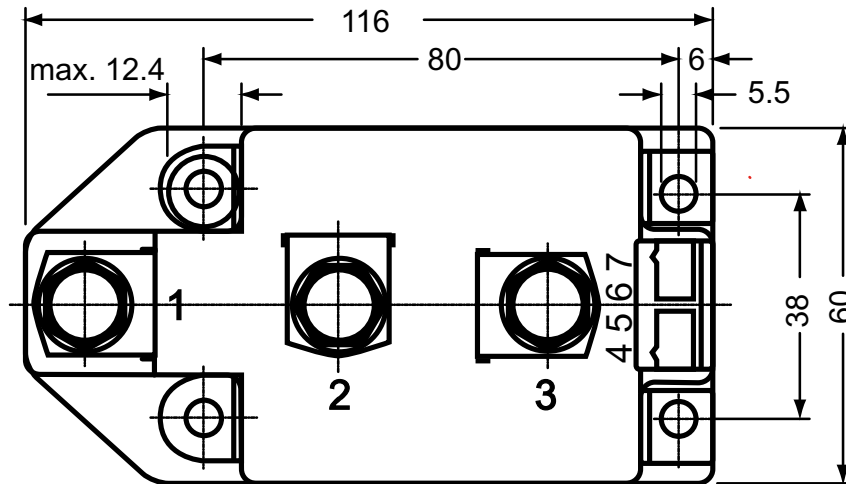
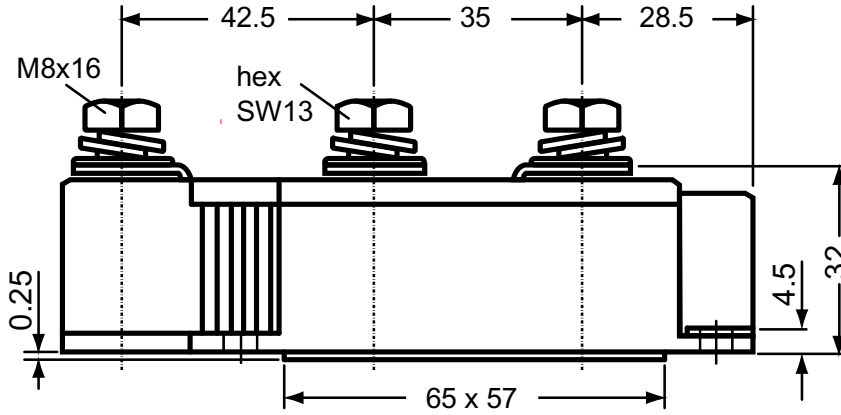

Threaded spacer for higher Anode / Cathode construction:

Type **ZY 250** (material brass)

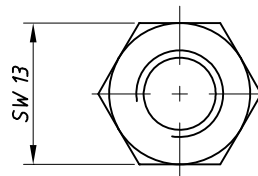

IXYS **MDD 220**

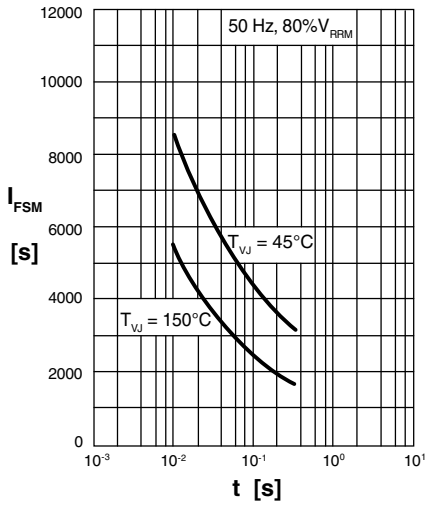

Fig. 1 Surge overload current
 I_{FSM} : Crest value, t : duration

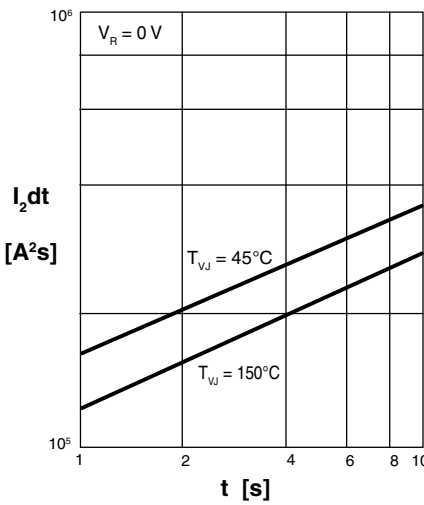

Fig. 2 I^2dt versus time (1-10 ms)

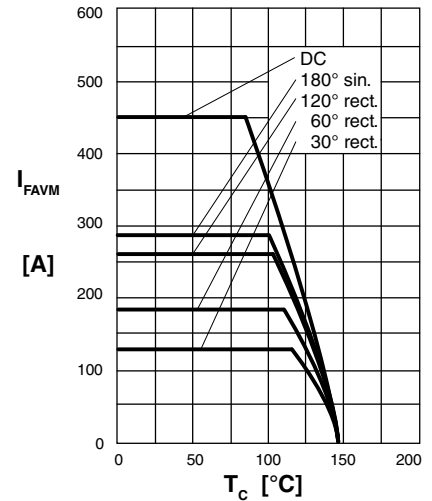

Fig. 2a Maximum forward current at case temperature

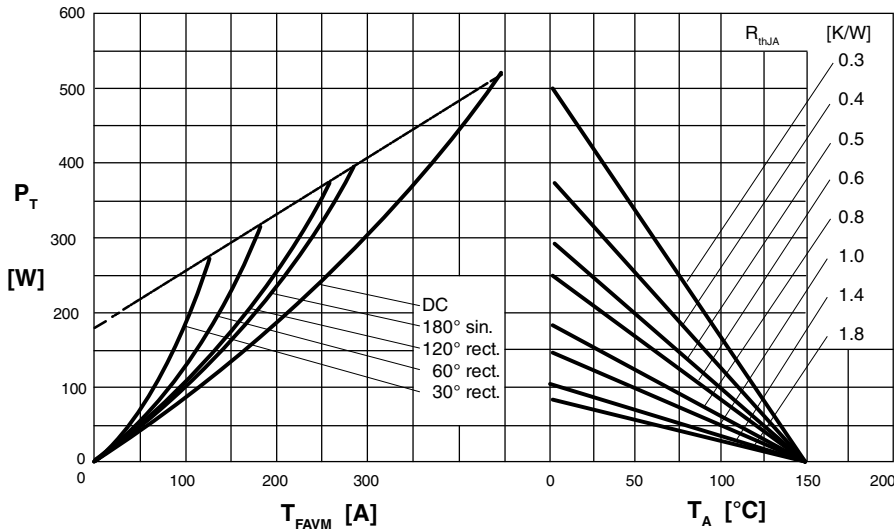
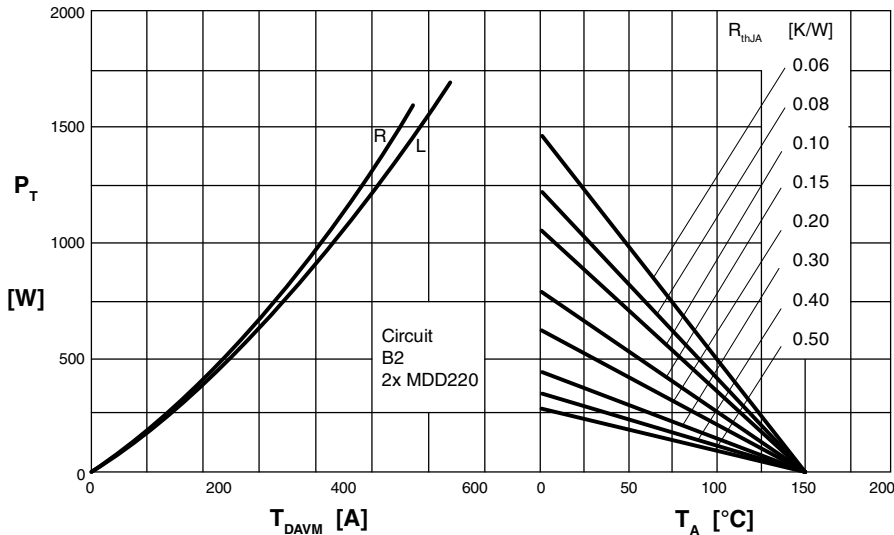

Fig. 3 Power dissipation vs. forward current and ambient temperature (per diode)



R = resistive load
 L = inductive load

Fig. 4 Single phase rectifier bridge: Power dissipation vs. direct output current and ambient temperature

IXYS **MDD 220**

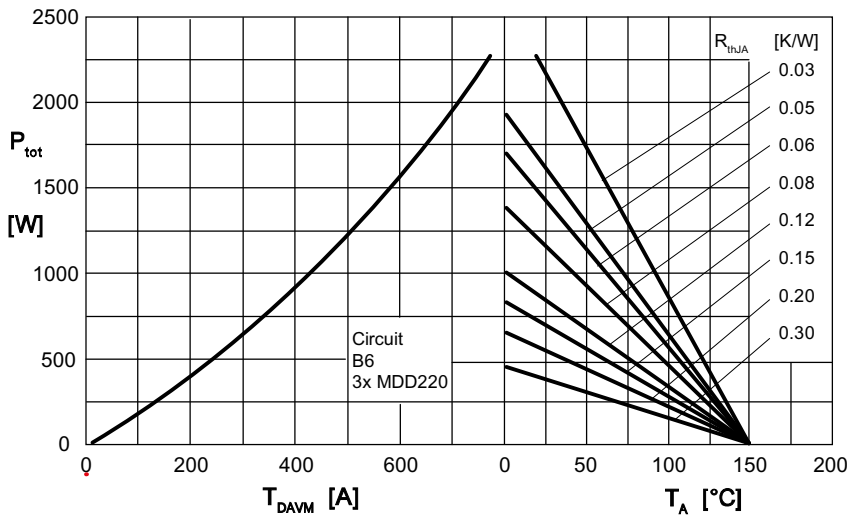

Fig. 5 Three phase rectifier bridge: Power dissipation versus direct output current and ambient temperature

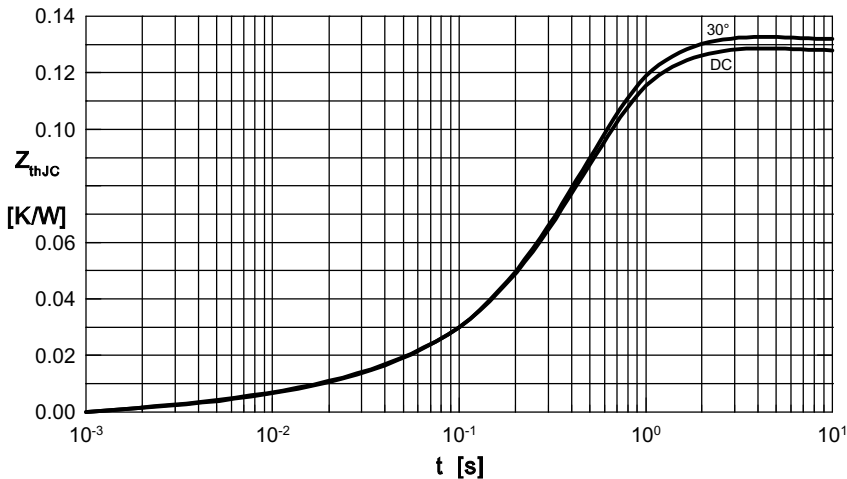

Fig. 6 Transient thermal impedance junction to case (per diode)

R_{thJC} for various conduction angles d

d	R_{thJC} [K/W]
DC	0.129
180°	0.131
120°	0.132
60°	0.132
30°	0.133

Constants for Z_{thJC} calculation:

i	R_{thi} [K/W]	t_i [s]
1	0.0035	0.0099
2	0.0165	0.168
3	0.1091	0.456

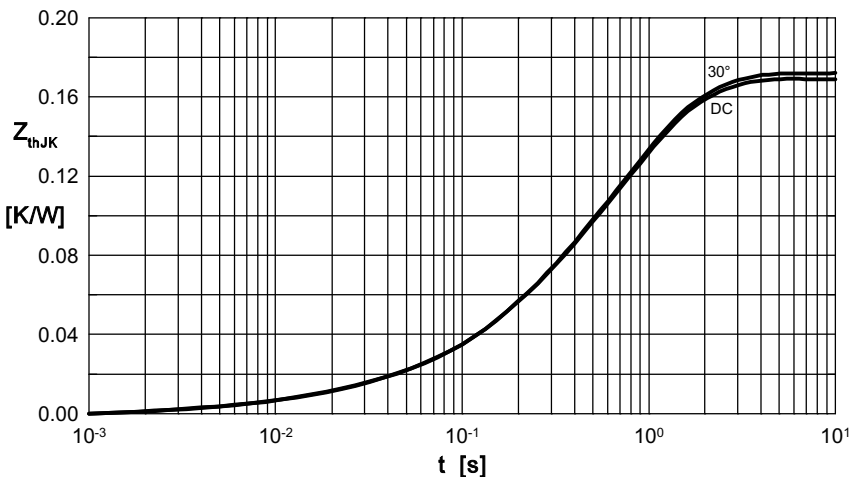

Fig. 7 Transient thermal impedance junction to heatsink (per diode)

R_{thJK} for various conduction angles d :

d	R_{thJK} (K/W)
DC	0.169
180°	0.171
120°	0.172
60°	0.172
30°	0.173

Constants for Z_{thJK} calculation:

i	R_{thi} (K/W)	t_i (s)
1	0.0035	0.0099
2	0.0165	0.168
3	0.1091	0.456
4	0.04	1.36