

Excellent Integrated System Limited

Stocking Distributor

Click to view price, real time Inventory, Delivery & Lifecycle Information:

[IXYS Corporation](#)

[VVZ40-14IO1](#)

For any questions, you can email us directly:

sales@integrated-circuit.com

IXYS VVZ 40

Three Phase Half Controlled Rectifier Bridge

$I_{dAVM} = 43 \text{ A}$
 $V_{RRM} = 1200\text{-}1600 \text{ V}$

V_{RSM} V_{DSM} V	V_{RRM} V_{DRM} V	Type
1300	1200	VVZ 40-12io1
1500	1400	VVZ 40-14io1
1700	1600	VVZ 40-16io1

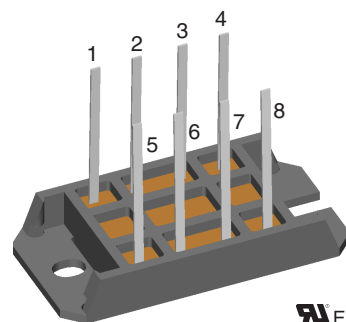
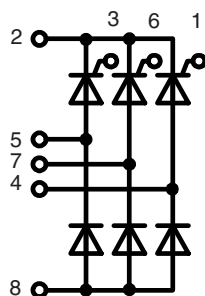

E72873

Symbol	Conditions	Maximum Ratings
I_{dAV}	$T_K = 100^\circ\text{C}$; module	34 A
I_{dAVM}	module	43 A
I_{FRMS}, I_{TRMS}	per leg	25 A
I_{FSM}, I_{TSM}	$T_{VJ} = 45^\circ\text{C}$; $V_R = 0$	$t = 10 \text{ ms}$ (50 Hz), sine 320 A $t = 8.3 \text{ ms}$ (60 Hz), sine 340 A
	$T_{VJ} = T_{VJM}$ $V_R = 0$	$t = 10 \text{ ms}$ (50 Hz), sine 290 A $t = 8.3 \text{ ms}$ (60 Hz), sine 310 A
I^2t	$T_{VJ} = 45^\circ\text{C}$ $V_R = 0$	$t = 10 \text{ ms}$ (50 Hz), sine 510 A ² s $t = 8.3 \text{ ms}$ (60 Hz), sine 485 A ² s
	$T_{VJ} = T_{VJM}$ $V_R = 0$	$t = 10 \text{ ms}$ (50 Hz), sine 420 A ² s $t = 8.3 \text{ ms}$ (60 Hz), sine 400 A ² s
$(di/dt)_{cr}$	$T_{VJ} = T_{VJM}$ $f = 400 \text{ Hz}$, $t_p = 200 \mu\text{s}$ $V_D = 2/3 V_{DRM}$ $I_G = 0.3 \text{ A}$, $di_G/dt = 0.3 \text{ A}/\mu\text{s}$	repetitive, $I_T = 50 \text{ A}$ 150 A/ μs
		non repetitive, $I_T = 1/3 \cdot I_{dAV}$ 500 A/ μs
$(dv/dt)_{cr}$	$T_{VJ} = T_{VJM}$; $V_{DR} = 2/3 V_{DRM}$ $R_{GK} = \infty$; method 1 (linear voltage rise)	1000 V/ μs
V_{RGM}		10 V
P_{GM}	$T_{VJ} = T_{VJM}$ $I_T = I_{TAVM}$	$t_p = 30 \mu\text{s}$ $\leq 10 \text{ W}$
		$t_p = 500 \mu\text{s}$ $\leq 5 \text{ W}$
		$t_p = 10 \text{ ms}$ $\leq 1 \text{ W}$
P_{GAVM}		0.5 W
T_{VJ}		-40...+125 °C
T_{VJM}		125 °C
T_{stg}		-40...+125 °C
V_{ISOL}	50/60 Hz, RMS	$t = 1 \text{ min}$ 3000 V~
	$I_{ISOL} \leq 1 \text{ mA}$	$t = 1 \text{ s}$ 3600 V~
M_d	Mounting torque (M5) (10-32 UNF)	2-2.5 Nm
		18-22 lb.in.
Weight	typ.	28 g

Features

- Package with DCB ceramic base plate
- Isolation voltage 3600 V~
- Planar passivated chips
- Soldering terminals
- UL registered E 72873

Applications

- Input rectifier for switch mode power supplies (SMPS)
- Softstart capacitor charging
- Electric drives and auxiliaries

Advantages

- Easy to mount with two screws
- Space and weight savings
- Improved temperature and power cycling

Data according to IEC 60747 and refer to a single thyristor/diode unless otherwise stated.

IXYS **VVZ 40**

Symbol	Conditions	Characteristic Values
I_R, I_D	$V_R = V_{RRM}; V_D = V_{DRM}$ $T_{VJ} = T_{VJM}$ $T_{VJ} = 25^\circ\text{C}$	≤ 5 mA ≤ 0.3 mA
V_F, V_T	$I_F, I_T = 30$ A, $T_{VJ} = 25^\circ\text{C}$	≤ 1.33 V
V_{T0}	For power-loss calculations only	0.85 V
r_T	($T_{VJ} = 125^\circ\text{C}$)	15 mΩ
V_{GT}	$V_D = 6$ V; $T_{VJ} = 25^\circ\text{C}$ $T_{VJ} = -40^\circ\text{C}$	≤ 1.0 V ≤ 1.2 V
I_{GT}	$V_D = 6$ V; $T_{VJ} = 25^\circ\text{C}$ $T_{VJ} = -40^\circ\text{C}$ $T_{VJ} = 125^\circ\text{C}$	≤ 65 mA ≤ 80 mA ≤ 50 mA
V_{GD}	$T_{VJ} = T_{VJM};$ $T_{VJ} = T_{VJM};$	≤ 0.2 V ≤ 5 mA
I_{GD}	$V_D = 2/3 V_{DRM}$ $V_D = 2/3 V_{DRM}$	
I_L	$I_G = 0.3$ A; $t_G = 30$ μs $di_G/dt = 0.3$ A/μs $T_{VJ} = 25^\circ\text{C}$ $T_{VJ} = -40^\circ\text{C}$ $T_{VJ} = 125^\circ\text{C}$	≤ 150 mA ≤ 200 mA ≤ 100 mA
I_H	$T_{VJ} = 25^\circ\text{C}; V_D = 6$ V; $R_{GK} = \infty$	≤ 100 mA
t_{gd}	$T_{VJ} = 25^\circ\text{C}; V_D = 1/2 V_{DRM}$ $I_G = 0.3$ A; $di_G/dt = 0.3$ A/μs	≤ 2 μs
t_q	$T_{VJ} = 125^\circ\text{C}; I_T = 15$ A, $t_p = 300$ μs, $-di/dt = 10$ A/μs	typ. 150 μs
Q_r	$V_R = 100$ V, $dv/dt = 20$ V/μs, $V_D = 2/3 V_{DRM}$	75 μC
R_{thJC}	per thyristor (diode); DC current per module	1.0 K/W 0.17 K/W
R_{thJH}	per thyristor (diode); DC current per module	1.6 K/W 0.27 K/W
d_s	Creeping distance on surface	7 mm
d_A	Creepage distance in air	7 mm
a	Max. allowable acceleration	50 m/s ²

Dimensions in mm (1 mm = 0.0394")

