

## Excellent Integrated System Limited

Stocking Distributor

Click to view price, real time Inventory, Delivery & Lifecycle Information:

[STMicroelectronics](#)  
[LM2903HD](#)

For any questions, you can email us directly:

[sales@integrated-circuit.com](mailto:sales@integrated-circuit.com)



# LM2903H

## LOW POWER DUAL VOLTAGE COMPARATORS

- WIDE SINGLE SUPPLY VOLTAGE RANGE OR DUAL SUPPLIES +2V TO +36V OR ±1V TO ±18V
- VERY LOW SUPPLY CURRENT (0.4mA) INDEPENDENT OF SUPPLY VOLTAGE (1mW/comparator at +5V)
- LOW INPUT BIAS CURRENT: 25nA TYP
- LOW INPUT OFFSET CURRENT: ±5nA TYP
- INPUT COMMON-MODE VOLTAGE RANGE INCLUDES GROUND
- LOW OUTPUT SATURATION VOLTAGE: 250mV TYP. ( $I_O = 4mA$ )
- DIFFERENTIAL INPUT VOLTAGE RANGE EQUAL TO THE SUPPLY VOLTAGE
- TTL, DTL, ECL, MOS, CMOS COMPATIBLE OUTPUTS

### DESCRIPTION

This device consists of two independent low power voltage comparators designed specifically to operate from a single supply over a wide range of voltages. Operation from split power supplies is also possible.

These comparators also have a unique characteristic in that the input common-mode voltage range includes ground even though operated from a single power supply voltage.

### ORDER CODE

| Part Number    | Temperature Range | Package |     |
|----------------|-------------------|---------|-----|
|                |                   | Wafer   | SO8 |
| JLM2903H- E6D1 | -40°C, +150°C     | •       |     |
| LM2903HD       | -40°C, +150°C     |         | •   |

D = Small Outline Package (SO) - also available in Tape & Reel (DT)

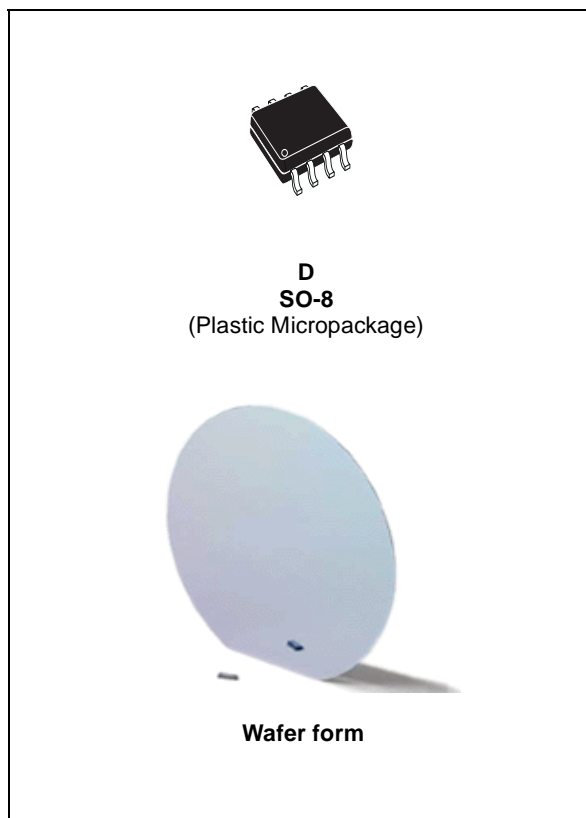

### PIN CONNECTIONS (top view)

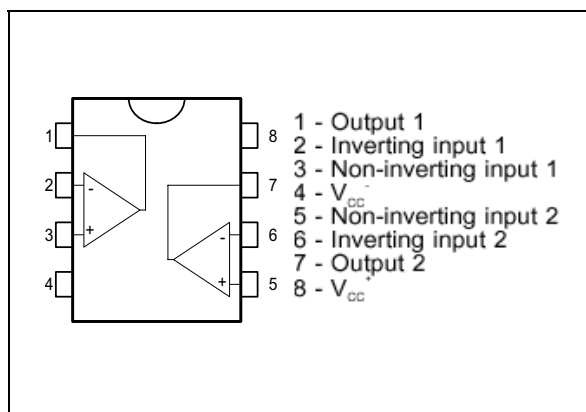

## LM2903H

### SCHEMATIC DIAGRAM (1/2 LM2903)

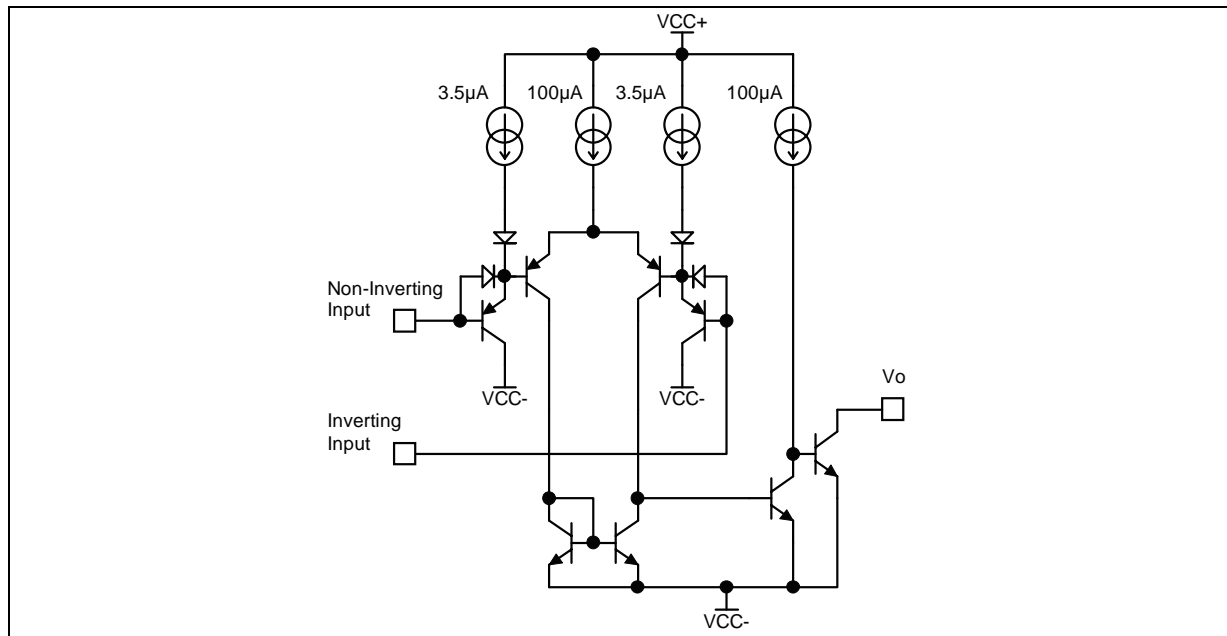

### PAD LOCATIONS

| Name  | Pad placement |     | Pad dimensions |    |
|-------|---------------|-----|----------------|----|
|       | X             | Y   | X              | Y  |
| GND   | 830           | 415 | 90             | 90 |
| E+1   | 750           | 100 | 90             | 90 |
| E-1   | 400           | 100 | 90             | 90 |
| OUT1  | 100           | 100 | 90             | 90 |
| Vcc + | 65            | 415 | 90             | 90 |
| OUT2  | 90            | 730 | 90             | 90 |
| E-2   | 410           | 720 | 90             | 90 |
| E+2   | 760           | 720 | 90             | 90 |

All dimensions are specified in micrometer (um).

### ABSOLUTE MAXIMUM RATINGS

| Symbol    | Parameter  | Value            | Unit       |
|-----------|--|------------------|------------|
| $V_{CC}$  | Supply Voltage   | $\pm 18$ or $36$ | V          |
| $V_{ID}$  | Differential Input Voltage                               | $\pm 36$         | V          |
| $V_I$     | Input Voltage  | $-0.3$ to $+36$  | V          |
|           | Output Short-circuit to Ground <sup>1)</sup>             | 20               | mA         |
| $P_d$     | Power Dissipation at $T_{AMB}=+25^\circ C$ <sup>2)</sup> | 710              | mW         |
| $T_{stg}$ | Storage Temperature Range                                | $-65$ to $+150$  | $^\circ C$ |

- Short-circuit from the output to  $V_{CC}^+$  can cause excessive heating and eventual destruction. The maximum output current is approximately 20mA, independent of the magnitude of  $V_{CC}^+$ .
- $P_d$  is calculated with  $T_{amb} = +25^\circ C$ ,  $T_{junction} = +150^\circ C$  and  $R_{thja} = 175^\circ C/W$  for SO8 package

**LM2903H**
**OPERATING CONDITIONS**

| Symbol     | Parameter                            | Value       | Unit |
|------------|--------------------------------------|-------------|------|
| $V_{CC}^+$ | Supply Voltage                       | 2 to 36     | V    |
| $T_{oper}$ | Operating Free-Air Temperature Range | -40 to +150 | °C   |

**ELECTRICAL CHARACTERISTICS**
 $V_{CC}^+ = 5V, V_{CC}^- = GND, T_{amb} = 25^\circ C$  (unless otherwise specified)

| Symbol     | Parameter   | Min.   | Typ.     | Max.                               | Unit          |
|------------|---|--------|----------|------------------------------------|---------------|
| $V_{IO}$   | Input Offset Voltage <sup>1)</sup><br>$T_{amb} = +25^\circ C$<br>$T_{min} \leq T_{amb} \leq T_{max}$ .  |        | 1        | 7<br>15                            | mV            |
| $I_{IO}$   | Input Offset Current<br>$T_{amb} = +25^\circ C$<br>$T_{min} \leq T_{amb} \leq T_{max}$ .  |        | 5        | 50<br>150                          | nA            |
| $I_{IB}$   | Input Bias Current <sup>2)</sup><br>$T_{amb} = +25^\circ C$<br>$T_{min} \leq T_{amb} \leq T_{max}$ .  |        | 25       | 250<br>400                         | nA            |
| $A_{VD}$   | Large Signal Voltage Gain ( $V_{CC} = 15V, R_L = 15k\Omega, V_O = 1$ to $11V$ )   | 25     | 200      |                                    | V/mV          |
| $I_{CC}$   | Supply Current (all comparators)<br>$V_{CC} = 5V$ , no load<br>$V_{CC} = 30V$ , no load   |        | 0.4<br>1 | 1<br>2.5                           | mA            |
| $V_{ICM}$  | Input Common Mode Voltage Range ( $V_{CC} = 30V$ ) <sup>3)</sup><br>$T_{amb} = +25^\circ C$<br>$T_{min} \leq T_{amb} \leq T_{max}$ .  | 0<br>0 |          | $V_{CC}^+ - 1.5$<br>$V_{CC}^+ - 2$ | V             |
| $V_{ID}$   | Differential Input Voltage <sup>4)</sup>  |        |          | $V_{CC}^+$                         | V             |
| $V_{OL}$   | Low Level Output Voltage ( $V_{id} = -1V, I_{sink} = 4mA$ )<br>$T_{amb} = +25^\circ C$<br>$T_{min} \leq T_{amb} \leq T_{max}$   |        | 250      | 400<br>800                         | mV            |
| $I_{OH}$   | High Level Output Current ( $V_{CC} = V_O = 30V, V_{id} = 1V$ )<br>$T_{amb} = +25^\circ C$<br>$T_{min} \leq T_{amb} \leq T_{max}$   |        | 0.1      | 1                                  | nA<br>$\mu A$ |
| $I_{SINK}$ | Output Sink Current ( $V_{id} = -1V, V_O = 1.5V$ )<br>$T_{amb} = +25^\circ C$<br>$T_{min} \leq T_{amb} \leq T_{max}$  | 6<br>2 | 16       |                                    | mA            |
| $t_{RE}$   | Small Signal Response Time <sup>5)</sup> ( $R_L = 5.1k\Omega$ to $V_{CC}^+$ )   |        | 1.3      |                                    | $\mu s$       |
| $t_{REL}$  | Large Signal Response Time <sup>6)</sup><br>TTL Input ( $V_{ref} = +1.4V, R_L = 5.1k\Omega$ to $V_{CC}^+$ )<br>Output Signal at 50% of final value<br>Output Signal at 95% of final value |        |          | 500<br>1                           | ns<br>$\mu s$ |

- At output switch point,  $V_O = 1.4V, R_S = 0\Omega$  with  $V_{CC}^+$  from 5V to 30V, and over the full input common-mode range (0V to  $V_{CC}^+ - 1.5V$ ).
- The direction of the input current is out of the IC due to the PNP input stage. This current is essentially constant, independent of the state of the output, so no loading charge exists on the reference of input lines
- The input common-mode voltage of either input signal voltage should not be allowed to go negative by more than 0.3V. The upper end of the common-mode voltage range is  $V_{CC}^+ - 1.5V$ , but either or both inputs can go to +30V without damage.
- Positive excursions of input voltage may exceed the power supply level. As long as the other voltage remains within the common-mode range, the comparator will provide a proper output state.  
The low input voltage state must not be less than -0.3V (or 0.3V below the negative power supply, if used)
- The response time specified is for a 100mV input step with 5mV overdrive.
- Maximum values are guaranteed by design & evaluation.

**LM2903H**

**SUPPLY CURRENT versus SUPPLY VOLTAGE**

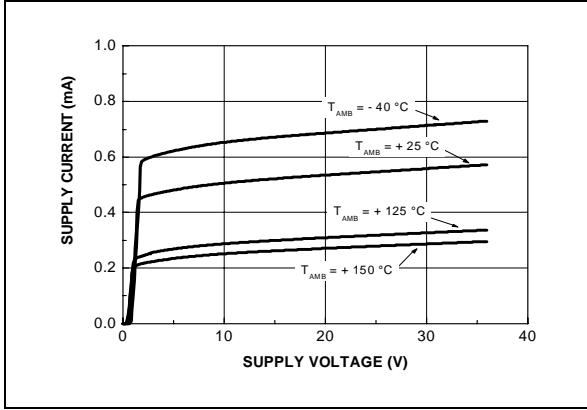

**RESPONSE TIME FOR VARIOUS INPUT OVERDRIVES - NEGATIVE TRANSITION**

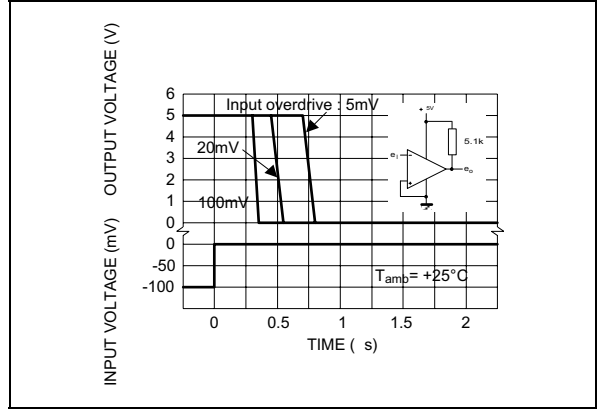

**INPUT CURRENT versus SUPPLY VOLTAGE**

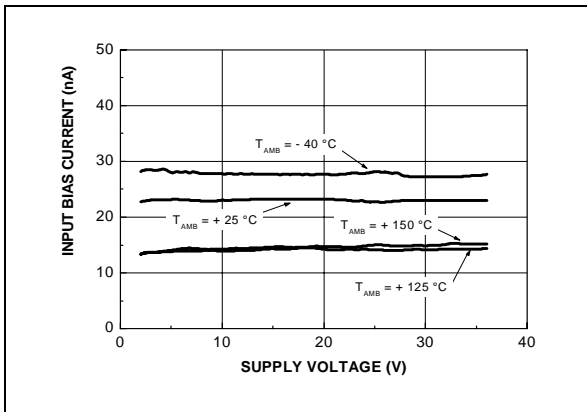

**RESPONSE TIME FOR VARIOUS INPUT OVERDRIVES - POSITIVE TRANSITION**

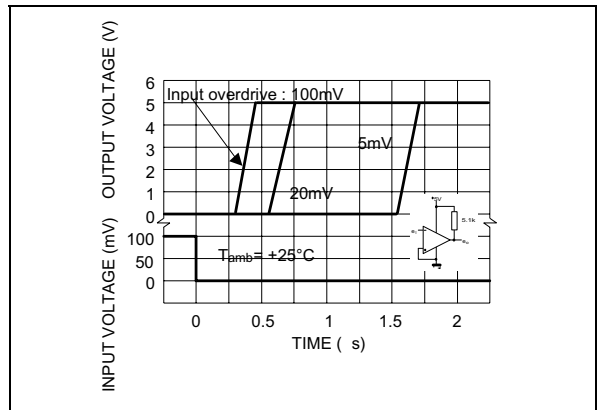

**OUTPUT SATURATION VOLTAGE versus OUTPUT CURRENT ( $V_{CC}=5V$ )**

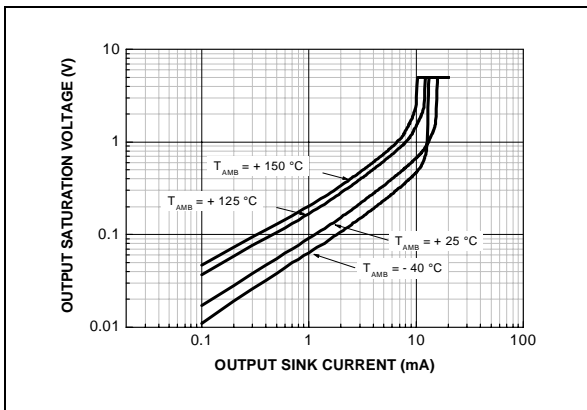

**PACKAGE MECHANICAL DATA**

**SO-8 MECHANICAL DATA**

| DIM. | mm.       |      |      | inch  |       |       |
|------|-----------|------|------|-------|-------|-------|
|      | MIN.      | TYP. | MAX. | MIN.  | TYP.  | MAX.  |
| A    | 1.35      |      | 1.75 | 0.053 |       | 0.069 |
| A1   | 0.10      |      | 0.25 | 0.04  |       | 0.010 |
| A2   | 1.10      |      | 1.65 | 0.043 |       | 0.065 |
| B    | 0.33      |      | 0.51 | 0.013 |       | 0.020 |
| C    | 0.19      |      | 0.25 | 0.007 |       | 0.010 |
| D    | 4.80      |      | 5.00 | 0.189 |       | 0.197 |
| E    | 3.80      |      | 4.00 | 0.150 |       | 0.157 |
| e    |           | 1.27 |      |       | 0.050 |       |
| H    | 5.80      |      | 6.20 | 0.228 |       | 0.244 |
| h    | 0.25      |      | 0.50 | 0.010 |       | 0.020 |
| L    | 0.40      |      | 1.27 | 0.016 |       | 0.050 |
| k    | 8° (max.) |      |      |       |       |       |
| ddd  |           |      | 0.1  |       |       | 0.04  |

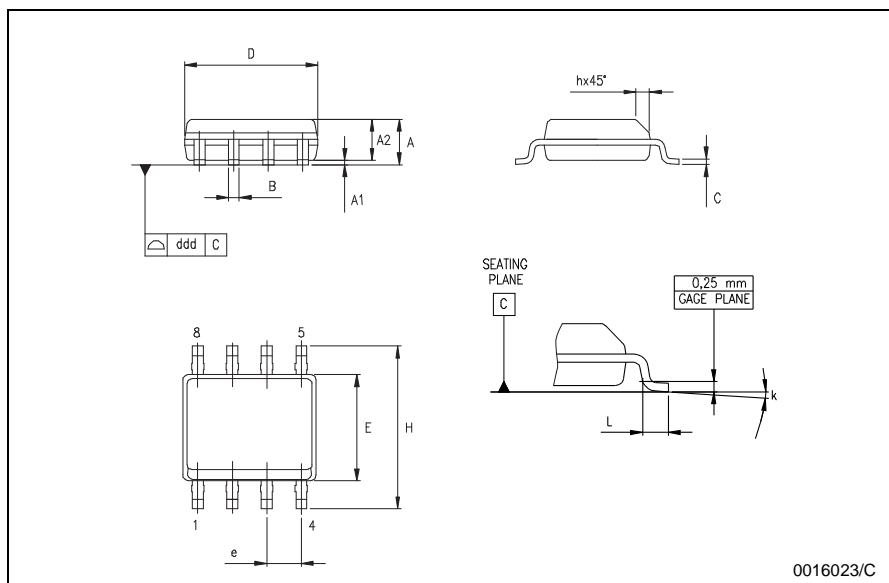

Information furnished is believed to be accurate and reliable. However, STMicroelectronics assumes no responsibility for the consequences of use of such information nor for any infringement of patents or other rights of third parties which may result from its use. No license is granted by implication or otherwise under any patent or patent rights of STMicroelectronics. Specifications mentioned in this publication are subject to change without notice. This publication supersedes and replaces all information previously supplied. STMicroelectronics products are not authorized for use as critical components in life support devices or systems without express written approval of STMicroelectronics.

The ST logo is a registered trademark of STMicroelectronics  
 All other names are the property of their respective owners.

© 2003 STMicroelectronics - All Rights Reserved

**STMicroelectronics GROUP OF COMPANIES**

Australia - Belgium - Brazil - Canada - China - Czech Republic - Finland - France - Germany  
 Hong Kong - India - Israel - Italy - Japan - Malaysia - Malta - Morocco - Singapore - Spain  
 Sweden - Switzerland - United Kingdom - United States

<http://www.st.com>