

Excellent Integrated System Limited

Stocking Distributor

Click to view price, real time Inventory, Delivery & Lifecycle Information:

[Maxim Integrated](#)
[MAX3784UTE+](#)

For any questions, you can email us directly:

sales@integrated-circuit.com

19-2565; Rev 4; 10/07

MAXIM

5Gbps PCB Equalizer

MAX3784/MAX3784A

General Description

The MAX3784/MAX3784A 5Gbps equalizers provide compensation for transmission-medium losses in up to 40in of FR-4. They are optimized for short-run length and balanced codes such as 8b10b, as found in multiplexed 1.25Gbps Ethernet systems and 4.25Gbps Fibre Channel.

The equalizers use differential CML data inputs and outputs. A standby mode reduces power consumption when the parts are not in use. The MAX3784/MAX3784A are available in a 4mm x 4mm, 16-pin QFN package that consumes only 185mW at +3.3V.

Pin Configurations

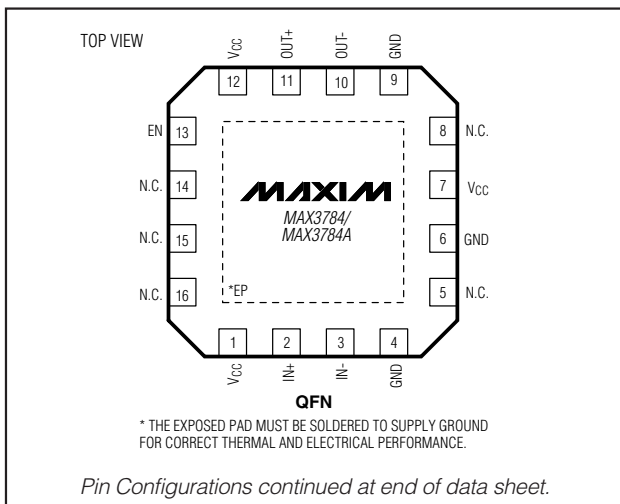

Features

- ◆ Spans 40in (1m) of FR-4 PCB
- ◆ 0.18UI Deterministic Jitter Up to 40in
- ◆ Low Power Consumption: 185mW (MAX3784)
- ◆ Equalization Reduces Intersymbol Interference
- ◆ Single +3.3V Supply
- ◆ Standby Mode
- ◆ Small 4mm x 4mm, 16-Pin QFN Package

Applications

- Chassis Life Extension
- 4.25Gbps Fibre Channel
- 4x Multiplexed 1.25Gbps Ethernet (5Gbps)

Ordering Information

PART	TEMP RANGE	PIN-PACKAGE	PKG CODE
MAX3784UGE	0°C to +85°C	16 QFN-EP*	G1644-1
MAX3784UTE+	0°C to +85°C	16 TQFN-EP*	T1644-3
MAX3784AUGE	0°C to +85°C	16 QFN-EP*	G1644-1
MAX3784AUTE+	0°C to +85°C	16 TQFN-EP*	T1644-3

+ Denotes a lead-free package.
 *Exposed pad.

Typical Application Circuit

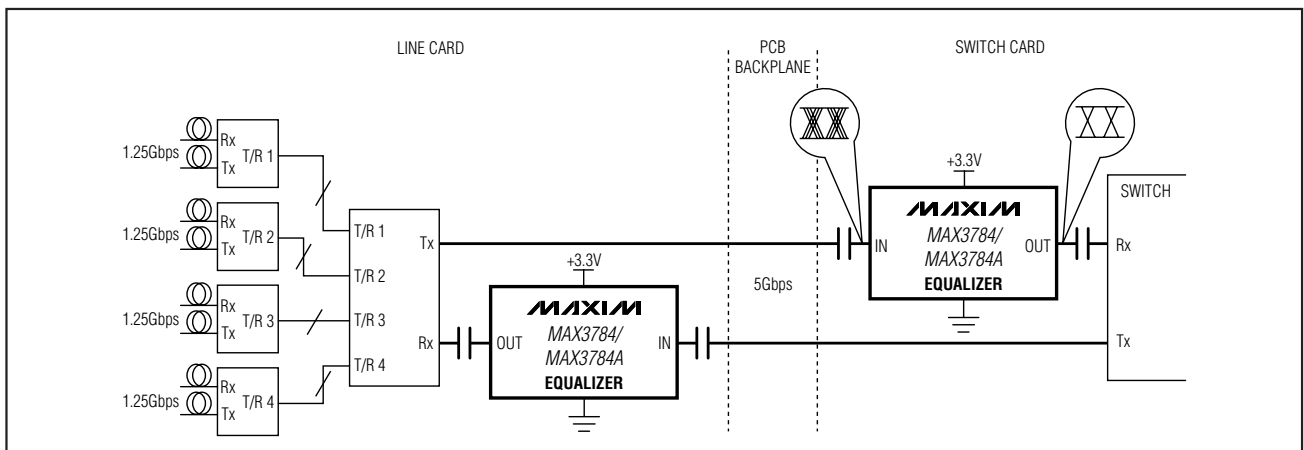

5Gbps PCB Equalizer

ABSOLUTE MAXIMUM RATINGS

Supply Voltage, V _{CC}	-0.5V to +6V	Operating Ambient Temperature Range	0°C to +85°C
Input Voltage.....	(-0.5V) to (V _{CC} + 0.5V)	Storage Temperature Range	-55°C to +150°C
Continuous Output Current.....	-25mA to +25mA	Lead Temperature (soldering, 10s)	+300°C
Continuous Power Dissipation (T _A = +85°C)			
16-Pin QFN (derate 25mW/°C above +85°C)	1600mW		

Stresses beyond those listed under "Absolute Maximum Ratings" may cause permanent damage to the device. These are stress ratings only, and functional operation of the device at these or any other conditions beyond those indicated in the operational sections of the specifications is not implied. Exposure to absolute maximum rating conditions for extended periods may affect device reliability.

ELECTRICAL CHARACTERISTICS

(V_{CC} = +3V to +3.6V, T_A = 0°C to +85°C. Typical values are at V_{CC} = +3.3V and T_A = +25°C, unless otherwise noted.)

PARAMETER	SYMBOL	CONDITIONS		MIN	TYP	MAX	UNITS
Supply Power		EN = low				30	mW
		EN = high			185	250	
Supply-Noise Tolerance		(Note 1)	10Hz < f < 100Hz		100		mV _{P-P}
			100Hz < f < 1MHz		40		
			1MHz < f < 2.5GHz		10		
Latency		From input to output			200		ps
CML RECEIVER INPUT							
Input Voltage Swing	V _{IN}	Measured differentially at point A in Figure 1		400		1000	mV _{P-P}
Return Loss		100MHz to 2.5GHz			15		dB
Input Resistance		Differential		80	100	120	Ω
EQUALIZATION							
Residual Deterministic Jitter, 5Gbps		Table 1 (Notes 2-5)	20in		0.13	0.21	UI _{P-P}
			40in		0.18	0.23	
Residual Deterministic Jitter, 2.5Gbps		Table 1 (Notes 2-5)	20in		0.08	0.14	UI _{P-P}
			40in		0.13	0.28	
Residual Deterministic Jitter, 1.25Gbps		Table 1 (Notes 2-5)	20in		0.04	0.07	UI _{P-P}
			40in		0.07	0.15	
Random Jitter		(Notes 5, 6)			1.3	1.9	psRMS
CML TRANSMITTER OUTPUT (into 100Ω ±1Ω)							
Output Voltage Swing	V _O	Differential swing, measured differentially at point C in Figure 1	MAX3784		400	600	mV _{P-P}
			MAX3784A		550	750	
Transition Time	t _f , t _r	20% to 80% (Notes 5, 8)		30	45	60	ps
Output Resistance		Single ended		40	50	60	Ω

5Gbps PCB Equalizer

ELECTRICAL CHARACTERISTICS (continued)

($V_{CC} = +3V$ to $+3.6V$, $T_A = 0^{\circ}C$ to $+85^{\circ}C$. Typical values are at $V_{CC} = +3.3V$ and $T_A = +25^{\circ}C$, unless otherwise noted.)

PARAMETER	SYMBOL	CONDITIONS	MIN	TYP	MAX	UNITS
ENABLE CONTROL PIN						
Input High Voltage			1.5			V
Input Low Voltage					0.5	V
Input High Current		(Note 7)	-150		+10	μA
Input Low Current		(Note 7)	-150		+10	μA

Note 1: Allowed supply noise during jitter tests.

Note 2: Test pattern. This is a combination of K28.5 \pm characters running at the full bit rate and at one-quarter the bit rate. This simulates the multiplexing of four each 1.25Gbps Ethernet data streams.

Pattern (hex) 100 bits

00 FFFF F0F0 FF 0000 0F0F (quarter rate K28.5+, quarter rate K28.5-)
 3EB05 (K28.5 \pm 00 1111 1010 11 0000 0101)

Note 3: Difference in deterministic jitter between reference points A and C in Figure 1.

Note 4: Signal source amplitude range is 400mV_{P-P} to 1000mV_{P-P} differential. Signal is applied differentially at point A as shown in Figure 1. The deterministic jitter at point B must be from media-induced loss and not from clock-source modulation.

Deterministic jitter is measured at the 50% vertical level of the signal at point C.

Note 5: Guaranteed by design and characterization.

Note 6: Test pattern is K28.5 with 40in trace.

Note 7: On-chip pullup resistor of 40k Ω (typ). Negative current indicates equalizer sources current.

Note 8: Using 00 0001 1111 or equivalent pattern. Measured over entire input voltage range, max and min media loss and within 2in of output pins.

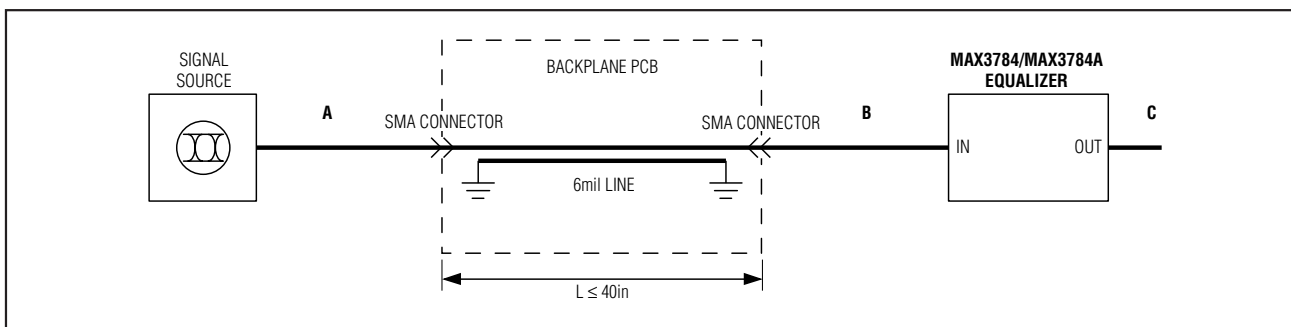

Figure 1. Test Conditions

Table 1. PCB Assumptions (PCB material is FR-4)

PARAMETER	CONDITIONS	MIN	TYP	MAX	UNITS
Transmission Line	Edge-coupled stripline		6		mils
Relative Permittivity	FR-4 or similar	4.4		4.5	—
Loss Tangent	FR-4 or similar	0.02		0.022	—
Metal Thickness	0.7 mils (0.5oz copper)		0.7		mils
Impedance	Differential	90	100	110	Ω

5Gbps PCB Equalizer

Typical Operating Characteristics

(V_{CC} = +3.3V, measurements done at 5Gbps, 800mV_{p-p} board input with 100-bit pattern from Note 2 of the EC Table, T_A = +25°C, unless otherwise noted.)

EQUALIZER INPUT EYE DIAGRAM BEFORE EQUALIZATION AT 5Gbps (40in, FR-4, 6-mil STRIPLINE)

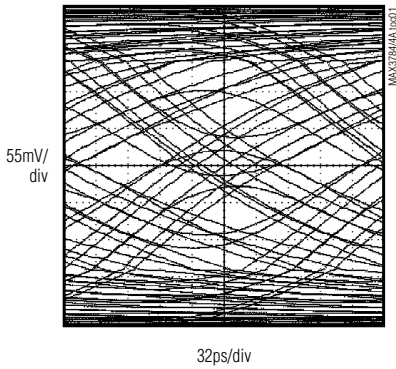

EQUALIZER OUTPUT EYE DIAGRAM AFTER EQUALIZATION AT 5Gbps (40in, FR-4, 6-mil STRIPLINE, MAX3784)

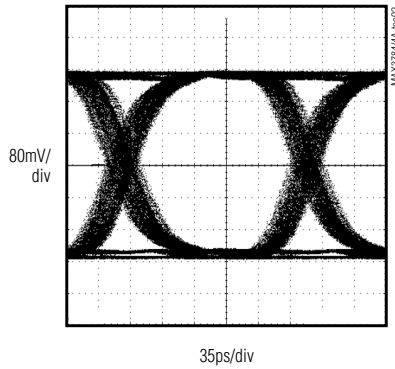

EQUALIZER OUTPUT EYE DIAGRAM AFTER EQUALIZATION AT 5Gbps (40in, FR-4, 6-mil STRIPLINE, MAX3784A)

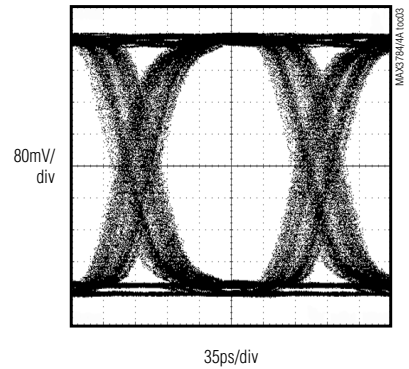

DIFFERENTIAL RETURN LOSS

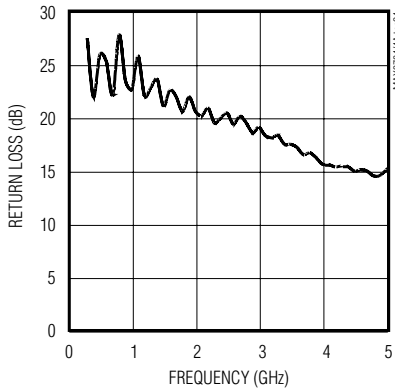

DETERMINISTIC JITTER vs. LINE LENGTH

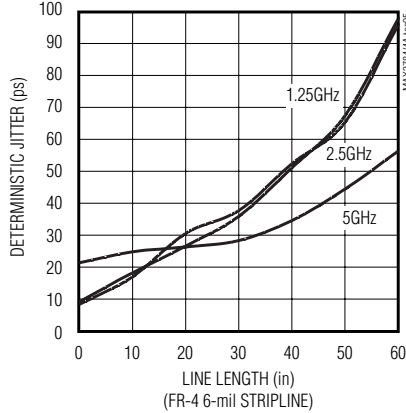

DETERMINISTIC JITTER vs. AMPLITUDE (20in FR-4 STRIPLINE)

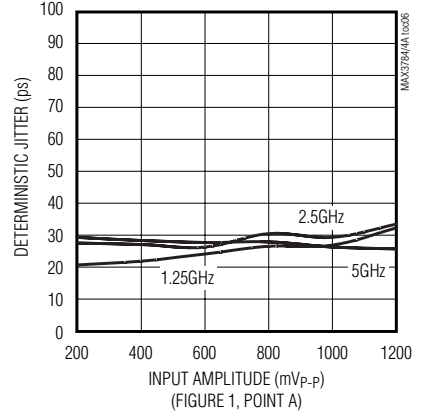

DETERMINISTIC JITTER vs. AMPLITUDE (40in FR-4 STRIPLINE)

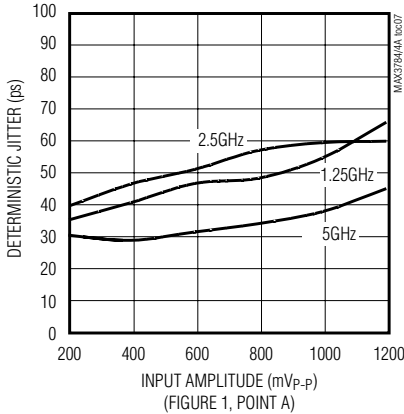

LATENCY vs. TEMPERATURE

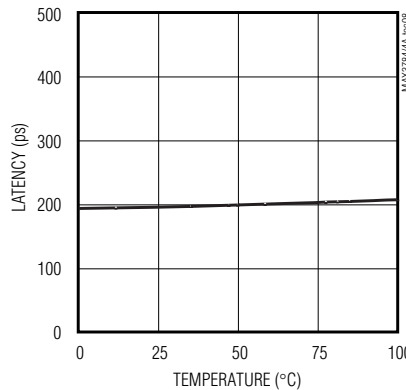

SUPPLY CURRENT vs. TEMPERATURE

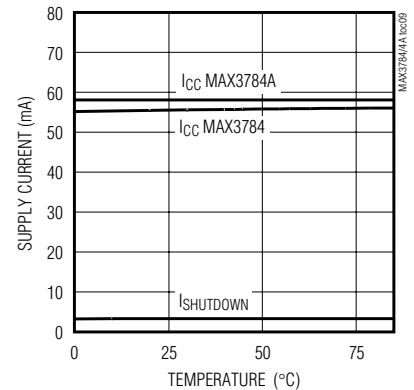

5Gbps PCB Equalizer

MAX3784/MAX3784A

Pin Description

PIN	NAME	FUNCTION
1, 7, 12	VCC	+3.3V Supply Voltage
2	IN+	Positive Input, CML
3	IN-	Negative Input, CML
4, 6, 9	GND	Supply Ground
5, 8, 14, 15, 16	N.C.	No Connection. Leave unconnected.
10	OUT-	Negative Output, CML
11	OUT+	Positive Output, CML
13	EN	Enable Equalizer. A logic high or open selects normal operation. A logic low selects low-power standby mode.
EP	Exposed Pad	Connect to Ground. The exposed pad must be soldered to the circuit board ground plane for proper thermal and electrical performance.

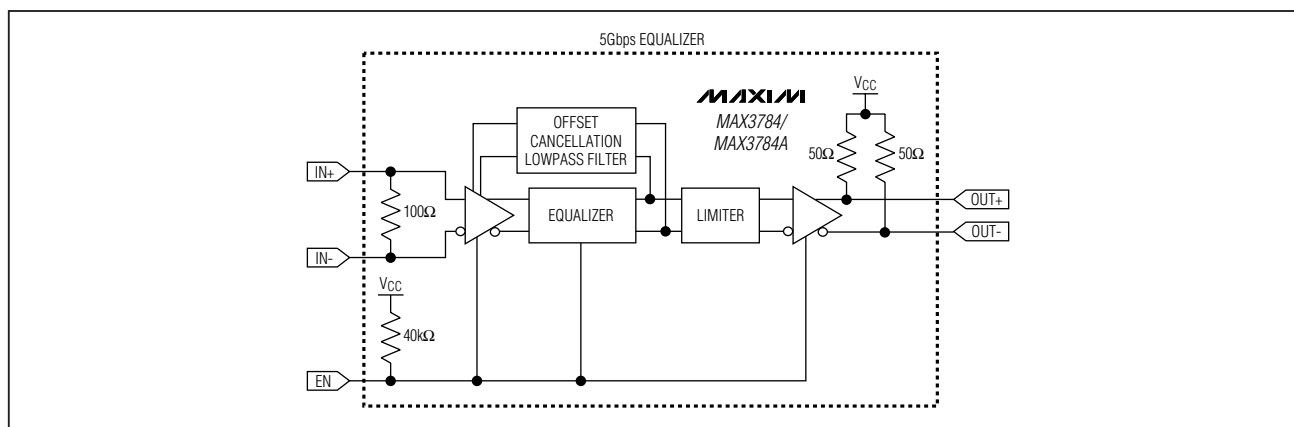

Figure 2. Functional Diagram

Detailed Description

General Theory of Operation

The MAX3784/MAX3784A adaptive equalizers extend the reach of transmission lines in high-frequency backplane interconnect applications. They can be used for 4.25Gbps Fibre Channel, 4x 1.25Gbps Ethernet (5Gbps) and other NRZ, 8b10b or short (≤ 20 bits) CID data types. Internally, the MAX3784/MAX3784A are comprised of an equalizer control loop and limiting output driver. The equalizer block reduces intersymbol interference (ISI), compensating for frequency-dependent media-induced loss. The equalization control detects the spectral contents of the input signal and provides a control voltage to the equalizer core, adapting it to different media. The equalizer operation is optimized for short-run, DC-balanced transmission codes.

Standby Mode

Standby saves power when the equalizer is not in use. The EN logic input must be set high or open for normal operation. Logic low at EN forces the equalizer into the standby state.

CML Input and Output Buffers

The input and output buffers are implemented using current-mode logic (CML). Equivalent circuits are shown in Figures 3 and 4. For details on interfacing with CML, refer to Maxim Application Note HFAN-01.0: *Introduction to LVDS, PECL, and CML*. The common-mode voltage of the input and output is above +2.5V. AC-coupling capacitors are required when interfacing this part with devices terminated in voltages such as +1.8V. Values of 0.10 μ F or greater are recommended.

5Gbps PCB Equalizer

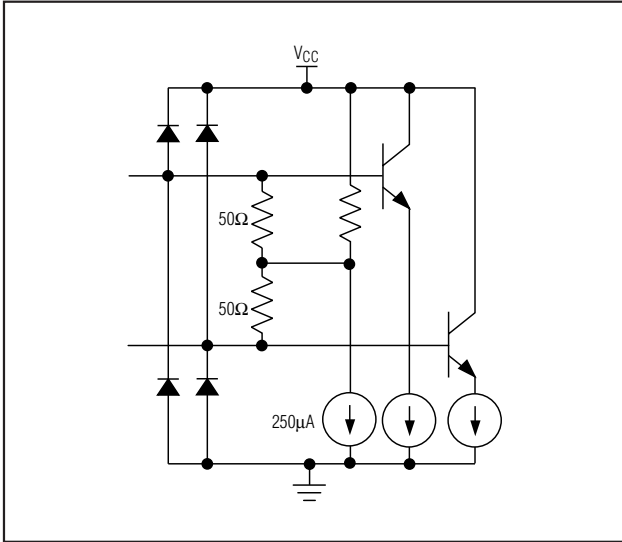

Figure 3. CML Input Equivalent Circuit

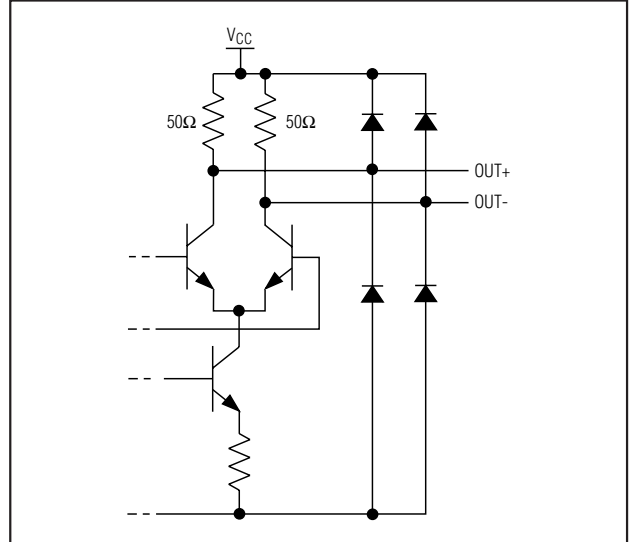

Figure 4. CML Output Equivalent Circuit

Applications Information

Alternate Data Rates

The MAX3784/MAX3784A is optimized for automatic operation at 5Gbps. Equalization at other data rates, such as 1.25Gbps and 2.5Gbps, is possible. See the *Typical Operating Characteristics for Deterministic Jitter vs. Line Length and Deterministic Jitter vs. Amplitude* for typical performance at these data rates.

Layout Considerations

Circuit board layout and design can significantly affect the MAX3784/MAX3784As' performance. Use good high-frequency design techniques, including minimizing ground inductance and connections and using controlled-impedance transmission lines for the high-frequency data signals. Route signals differentially to reduce EMI susceptibility and crosstalk. Solder the exposed pad to supply ground for proper thermal and electrical operation.

Place power-supply decoupling capacitors as close as possible to the VCC pins.

Pin Configurations (continued)

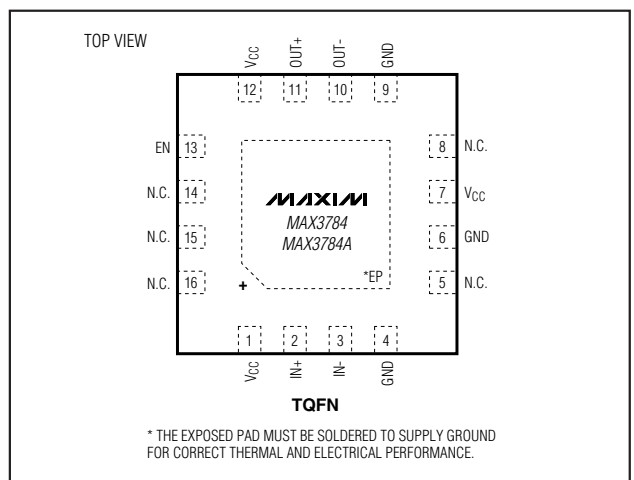

5Gbps PCB Equalizer

Package Information

For the latest package outline information, go to www.maxim-ic.com/packages.

PACKAGE TYPE	DOCUMENT NO.
16 QFN	21-0106
16 TQFN	21-0139

Revision History

Pages changed at Rev 4: 1–7 (removed package drawings, replaced with table)

MAX3784/MAX3784A

Maxim cannot assume responsibility for use of any circuitry other than circuitry entirely embodied in a Maxim product. No circuit patent licenses are implied. Maxim reserves the right to change the circuitry and specifications without notice at any time.

Maxim Integrated Products, 120 San Gabriel Drive, Sunnyvale, CA 94086 408-737-7600 _____ 7