

Excellent Integrated System Limited

Stocking Distributor

Click to view price, real time Inventory, Delivery & Lifecycle Information:

[Fairchild Semiconductor](#)
[MM74HCT273N](#)

For any questions, you can email us directly:

sales@integrated-circuit.com



February 1984
Revised May 2005

MM74HCT273 Octal D-Type Flip-Flop with Clear

General Description

The MM74HCT273 utilizes advanced silicon-gate CMOS technology. It has an input threshold and output drive similar to LS-TTL with the low standby power of CMOS.

These positive edge-triggered flip-flops have a common clock and clear-independent Q outputs. Data on a D input, having the specified set-up and hold time, is transferred to the corresponding Q output on the positive-going transition of the clock pulse. The asynchronous clear forces all outputs LOW when it is LOW.

All inputs to this device are protected from damage due to electrostatic discharge by diodes to V_{CC} and ground.

MM74HCT devices are intended to interface TTL and NMOS components to CMOS components. These parts can be used as plug-in replacements to reduce system power consumption in existing designs.

Features

- Typical propagation delay: 20 ns
- Low quiescent current: 80 μ A maximum (74HCT series)
- Fanout of 10 LS-TTL loads

Ordering Code:

Order Number	Package Number	Package Description
MM74HCT273WM	M20B	20-Lead Small Outline Integrated Circuit (SOIC), JEDEC MS-013, 0.300" Wide
MM74HCT273SJ	M20D	20-Lead Small Outline Package (SOP), EIAJ TYPE II, 5.3mm Wide
MM74HCT273MTC	MTC20	20-Lead Thin Shrink Small Outline Package (TSSOP), JEDEC MO-153, 4.4mm Wide
MM74HCT273N	N20A	20-Lead Plastic Dual-In-Line Package (PDIP), JEDEC MS-001, 0.300" Wide

Devices also available in Tape and Reel. Specify by appending the suffix letter "X" to the ordering code.

Connection Diagram

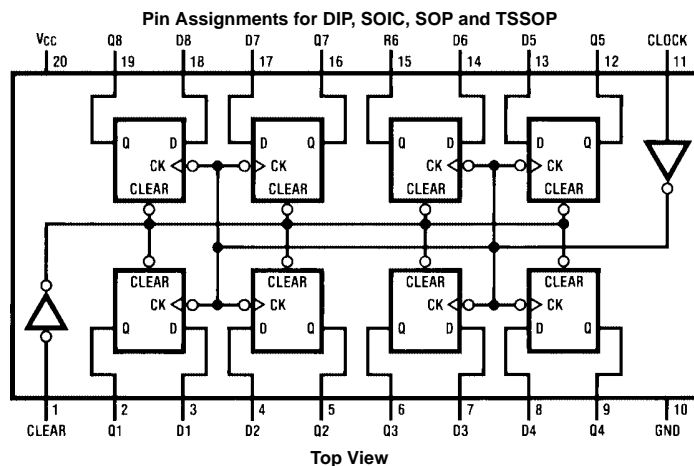

MM74HCT273

Truth Table

(Each Flip-Flop)

Inputs			Outputs
Clear	Clock	D	Q
L	X	X	L
H	↑	H	H
H	↑	L	L
H	L	X	Q0

H = HIGH Level (steady-state)
 L = LOW Level (steady-state)
 X = Don't Care
 ↑ = Transition from LOW-to-HIGH level
 Q0 = The level of Q before the indicated steady-state input conditions were established.

Logic Diagram

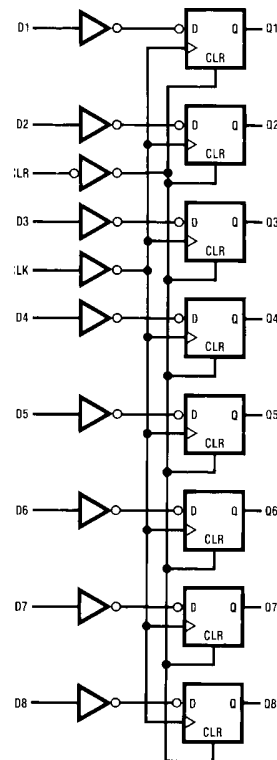

Absolute Maximum Ratings (Note 1)		Recommended Operating Conditions					
(Note 2)							
Supply Voltage (V_{CC})	-0.5V to + 7.0V	Min	Max Units				
DC Input Voltage (V_{IN})	-1.5V to $V_{CC} + 1.5V$	4.5	5.5 V				
DC Output Voltage (V_{OUT})	-0.5V to $V_{CC} + 0.5V$	DC Input or Output Voltage					
Clamp Diode Current (I_{IK}, I_{OK})	± 20 mA	0	V_{CC} V				
DC Output Current, per Pin (I_{OUT})	± 25 mA	Operating Temperature Range (T_A)					
DC V_{CC} or GND Current, per Pin (I_{CC})	± 50 mA	-40	+85 °C				
Storage Temperature Range (T_{STG})	-65°C to + 150°C	Input Rise or Fall Times					
Power Dissipation (P_D)		(t_r, t_f)	500 ns				
(Note 3)	600 mW	Note 1: Absolute Maximum Ratings are those values beyond which damage to the device may occur.					
S.O. Package only	500 mW	Note 2: Unless otherwise specified all voltages are referenced to ground.					
Lead Temperature (T_L)		Note 3: Power dissipation temperature derating—plastic "N" package: -12 mW/°C from 65°C to 85°C.					
(Soldering, 10 seconds)	260°C						
DC Electrical Characteristics							
$V_{CC} = 5V \pm 10\%$ unless otherwise specified							
Symbol	Parameter	Conditions	$T_A = 25^\circ C$	$T_A = -40^\circ C$ to $85^\circ C$	$T_A = -55^\circ C$ to $125^\circ C$	Units	
			Typ	Guaranteed Limits			
V_{IH}	Minimum HIGH Level Input Voltage		2.0	2.0	2.0	V	
V_{IL}	Maximum LOW Level Input Voltage		0.8	0.8	0.8	V	
V_{OH}	Minimum HIGH Level Output Voltage	$V_{IN} = V_{IH}$ or V_{IL}	V_{CC}	$V_{CC}-0.1$	$V_{CC}-0.1$	$V_{CC}-0.1$	V
		$I_{OUT} = 20 \mu A$	4.2	3.98	3.84	3.7	V
		$I_{OUT} = 4.0$ mA, $V_{CC} = 4.5V$	5.2	4.98	4.84	4.7	V
V_{OL}	Minimum LOW Level Voltage	$V_{IN} = V_{IH}$ or V_{IL}	0	0.1	0.1	0.1	V
		$I_{OUT} = 20 \mu A$	0.2	0.26	0.33	0.4	V
		$I_{OUT} = 4.0$ mA, $V_{CC} = 4.5V$	0.2	0.26	0.33	0.4	V
I_{IN}	Maximum Input Current	$V_{IN} = V_{CC}$ or GND, V_{IH} or V_{IL}		± 0.1	± 1.0	± 1.0	μA
				8	80	160	μA
I_{CC}	Maximum Quiescent Supply Current	$V_{IN} = V_{CC}$ or GND, $I_{OUT} = 0 \mu A$		0.6	0.8	0.9	mA
		$V_{IN} = 2.4V$ or 0.5V (Note 4)					
Note 4: Measured per pin, all other inputs held at V_{CC} or GND.							

MM74HCT273

AC Electrical Characteristics					
$V_{CC} = 5V, T_A = 25^{\circ}C, C_L = 15 pF, t_r = t_f = 6 ns$					
Symbol	Parameter	Conditions	Typ	Guaranteed Limits	Units
f_{MAX}	Maximum Operating Frequency		68	30	MHz
t_{PHL}, t_{PLH}	Maximum Propagation Delay from Clock to Q		18	30	ns
t_{PHL}, t_{PLH}	Maximum Propagation Delay from Clear to Q		21	30	ns
t_{REM}	Minimum Removal Time, Clear to Clock		-1	5	ns
t_S	Minimum Set-Up Time D to Clock		6	20	ns
t_H	Minimum Hold Time Clock to D		-3	5	ns
t_W	Minimum Pulse Width Clock or Clear		10	16	ns

AC Electrical Characteristics									
$V_{CC} = 5.0V \pm 10\%, C_L = 50 pF, t_r = t_f = 6 ns$ unless otherwise specified									
Symbol	Parameter	Conditions	$T_A = 25^{\circ}C$		$T_A = -40^{\circ}C$ to $85^{\circ}C$		$T_A = -55^{\circ}C$ to $125^{\circ}C$		Units
			Typ	Guaranteed Limits	Typ	Guaranteed Limits	Typ	Guaranteed Limits	
f_{MAX}	Maximum Operating Frequency		68	27	21	18			MHz
t_{PHL}, t_{PLH}	Maximum Propagation Delay from Clock to Q		22	37	46	56			ns
t_{PHL}, t_{PLH}	Maximum Propagation Delay from Clear to Q		25	35	44	52			ns
t_{REM}	Minimum Removal Time Clear to Clock		-1	5	6	7			ns
t_S	Minimum Set-Up Time D to Clock		6	20	25	30			ns
t_H	Minimum Hold Time Clock to D		-3	5	5	5			ns
t_W	Minimum Pulse Width Clock or Clear		10	16	25	30			ns
t_r, t_f	Maximum Input Rise and Fall Time, Clock			500	500	500			ns
t_{THL}, t_{TLH}	Maximum Output Rise and Fall Time		11	15	19	22			ns
C_{PD}	Power Dissipation Capacitance (Note 5)	(Per Flip-Flop)	50						pF
C_{IN}	Maximum Input Capacitance		6	10	10	10			pF

Note 5: C_{PD} determines the no load dynamic power consumption, $P_D = C_{PD} V_{CC}^2 f + I_{CC} V_{CC}$, and the no load dynamic current consumption, $I_S = C_{PD} V_{CC}^2 f + I_{CC}$.

MM74HCT273

Physical Dimensions inches (millimeters) unless otherwise noted

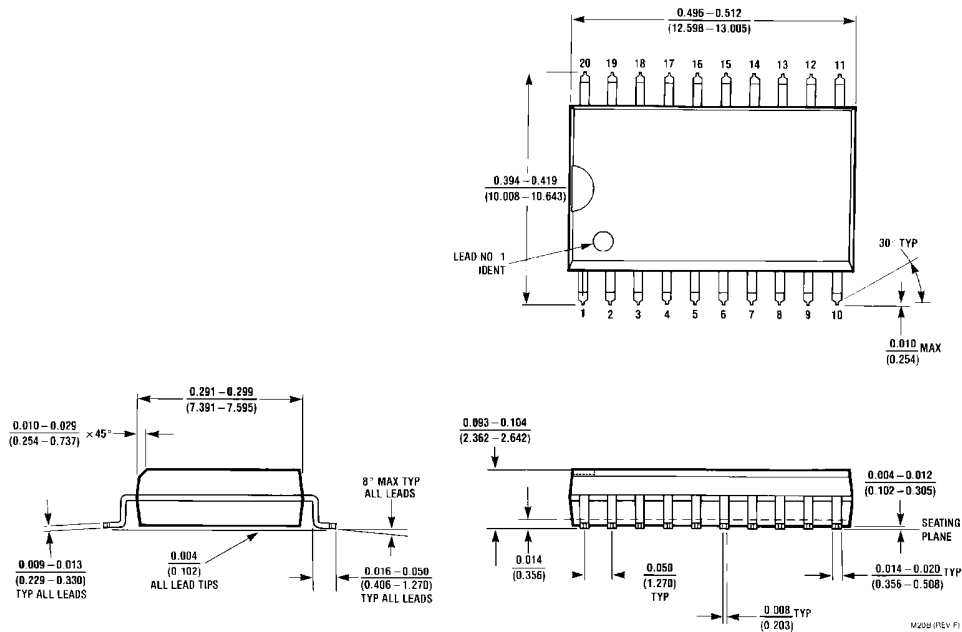

20-Lead Small Outline Integrated Circuit (SOIC), JEDEC MS-013, 0.300" Wide
 Package Number M20B

MM74HCT273

Physical Dimensions inches (millimeters) unless otherwise noted (Continued)

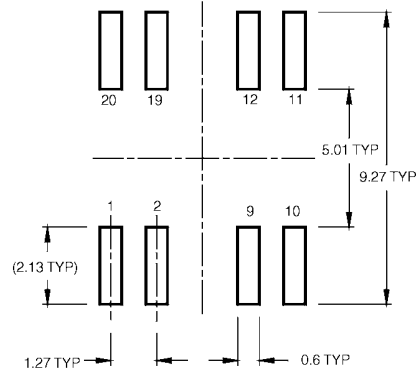
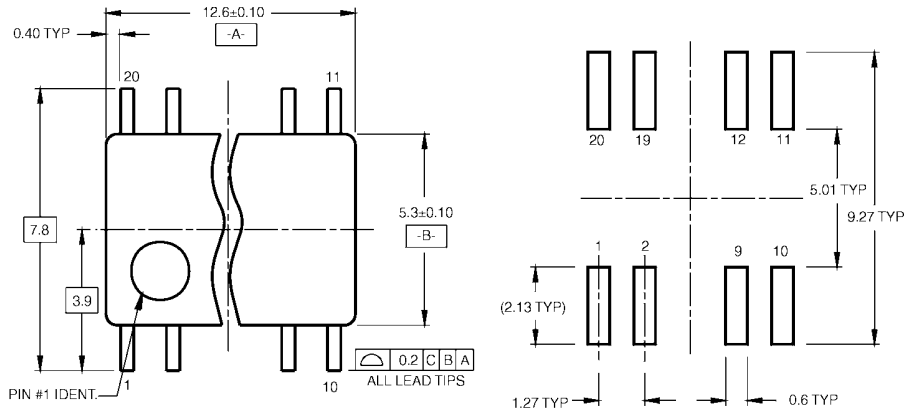

LAND PATTERN RECOMMENDATION

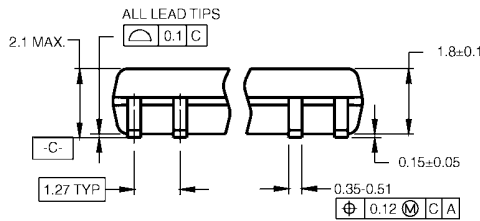

DIMENSIONS ARE IN MILLIMETERS

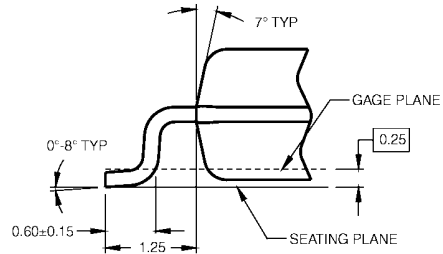
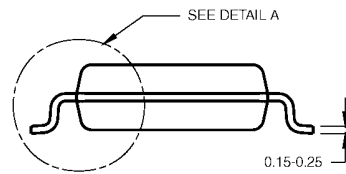

DETAIL A

NOTES:

- A. CONFORMS TO EIAJ EDR-7320 REGISTRATION, ESTABLISHED IN DECEMBER, 1998.
- B. DIMENSIONS ARE IN MILLIMETERS.
- C. DIMENSIONS ARE EXCLUSIVE OF BURRS, MOLD FLASH, AND TIE BAR EXTRUSIONS.

M20DRRevB1

**20-Lead Small Outline Package (SOP), EIAJ TYPE II, 5.3mm Wide
Package Number M20D**

Physical Dimensions inches (millimeters) unless otherwise noted (Continued)

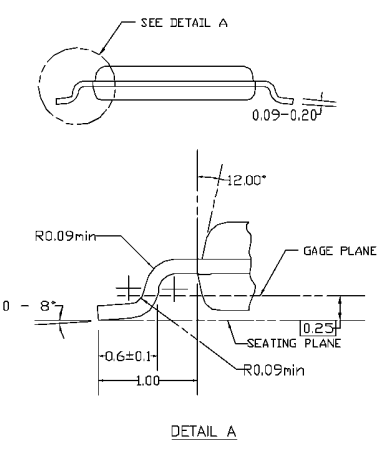
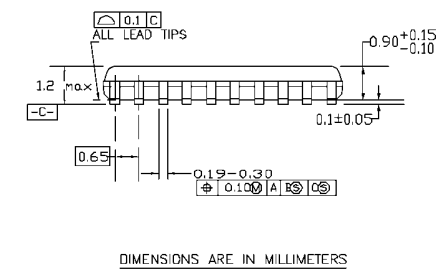
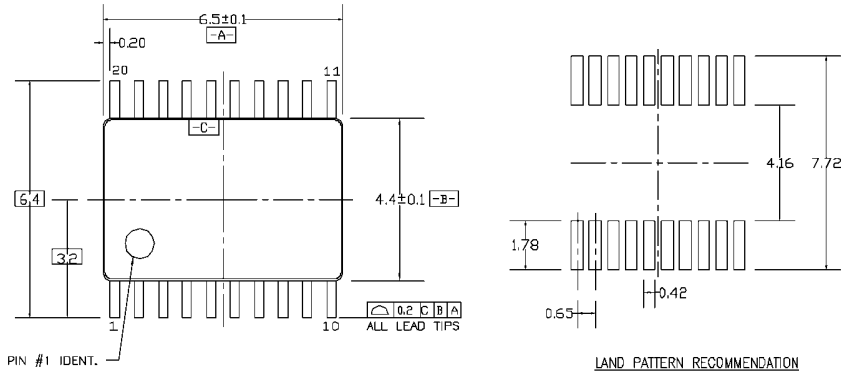

DIMENSIONS ARE IN MILLIMETERS

- NOTES:
- A. CONFORMS TO JEDEC REGISTRATION MO-153, VARIATION AC, REF NOTE 8, DATE 7/93.
 - B. DIMENSIONS ARE IN MILLIMETERS.
 - C. DIMENSIONS ARE EXCLUSIVE OF BURRS, MOLDS FLASH, AND TIE BAR EXTRUSIONS.
 - D. DIMENSIONS AND TOLERANCES PER ANSI Y14.5M, 1982.

MTC20REVD1

20-Lead Thin Shrink Small Outline Package (TSSOP), JEDEC MO-153, 4.4mm Wide Package Number MTC20

MM74HCT273 Octal D-Type Flip-Flop with Clear

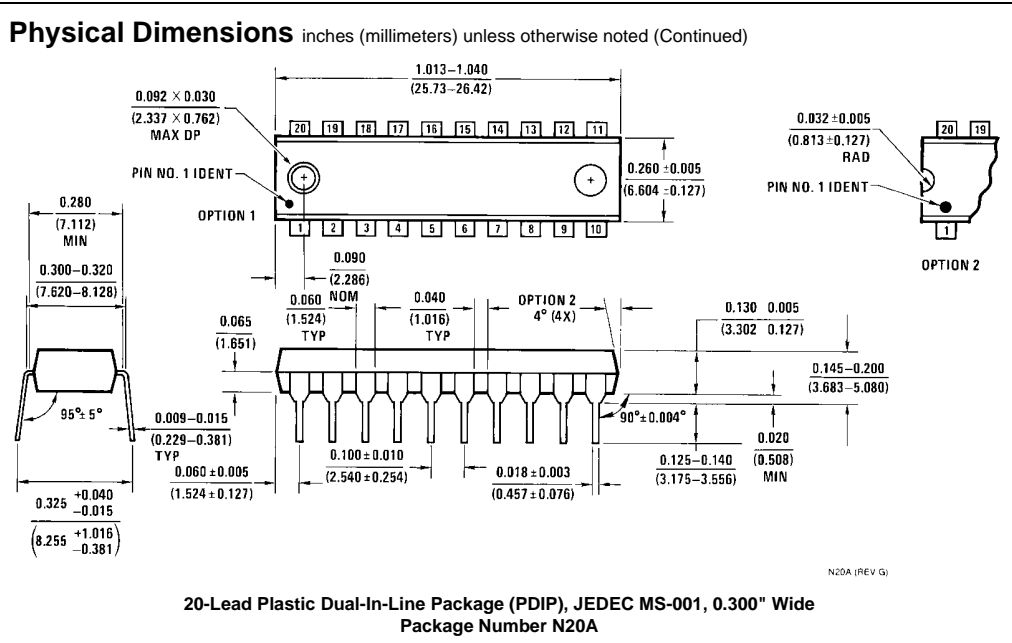

Fairchild does not assume any responsibility for use of any circuitry described, no circuit patent licenses are implied and Fairchild reserves the right at any time without notice to change said circuitry and specifications.

LIFE SUPPORT POLICY

FAIRCHILD'S PRODUCTS ARE NOT AUTHORIZED FOR USE AS CRITICAL COMPONENTS IN LIFE SUPPORT DEVICES OR SYSTEMS WITHOUT THE EXPRESS WRITTEN APPROVAL OF THE PRESIDENT OF FAIRCHILD SEMICONDUCTOR CORPORATION. As used herein:

1. Life support devices or systems are devices or systems which, (a) are intended for surgical implant into the body, or (b) support or sustain life, and (c) whose failure to perform when properly used in accordance with instructions for use provided in the labeling, can be reasonably expected to result in a significant injury to the user.
2. A critical component in any component of a life support device or system whose failure to perform can be reasonably expected to cause the failure of the life support device or system, or to affect its safety or effectiveness.

www.fairchildsemi.com