



Excellent Integrated System Limited

Stocking Distributor

Click to view price, real time Inventory, Delivery & Lifecycle Information:

[Molex Connector Corporation](#)
[11-01-0185](#)

For any questions, you can email us directly:
sales@integrated-circuit.com

Hand Crimp Tool for .100 KK



**HAND CRIMP TOOL
 SPECIFICATION SHEET
 Order No. 11-01-0185
 (CR2262C)**

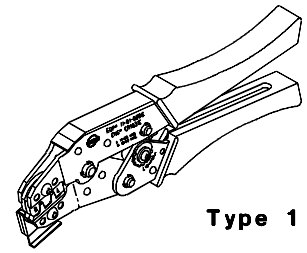

Type 1

FEATURES

- Small handle spread which make this style tool ideally suited for end users
- Ratchet with safety release that ensures consistent performance
- A precision user-friendly terminal locator wire stop holds terminals in the proper crimping position

SCOPE

Terminal Series No.	Wire Size		Insulation Diameter		Strip Length	
	AWG	mm ²	mm	In.	mm	In.
1854	24-30	0.20-0.05	1.02-2.29	.040-.090	3.17-3.96	.125-.156
1855	24-30	0.20-0.05	1.02-2.29	.040-.090	3.17-3.96	.125-.156
2189	24-30	0.20-0.05	1.02-2.29	.040-.090	3.17-3.96	.125-.156
2190	24-30	0.20-0.05	1.02-2.29	.040-.090	3.17-3.96	.125-.156
2717	24-30	0.20-0.05	1.02-2.29	.040-.090	3.17-3.96	.125-.156
2759	22-30	0.35-0.05	1.02-1.57	.040-.062	2.54-3.17	.100-.125
2951	24-30	0.20-0.05	1.02-2.29	.040-.090	3.17-3.96	.125-.156
40445	22-30	0.35-0.05	1.02-1.57	.040-.062	2.54-3.17	.100-.125
41572	22-30	0.20-0.05	1.02-2.29	.040-.090	3.17-3.96	.125-.156
4548	24-30	0.20-0.05	1.02-2.29	.040-.090	3.17-3.96	.125-.156
4559	24-30	0.20-0.05	1.02-2.29	.040-.090	3.17-3.96	.125-.156
4809	22-30	0.35-0.05	1.02-1.57	.040-.062	2.54-3.17	.100-.125
5159	24-30	0.20-0.05	1.02-2.29	.040-.090	3.17-3.96	.125-.156
6459	22-30	0.35-0.05	1.02-1.57	.040-.062	2.54-3.17	.100-.125
6796	24-30	0.20-0.05	1.02-2.29	.040-.090	3.17-3.96	.125-.156
7879	22-30	0.35-0.05	1.02-1.57	.040-.062	2.54-3.17	.100-.125
8088	22-30	0.35-0.05	1.02-1.57	.040-.062	2.54-3.17	.100-.125

DEFINITION OF TERMS

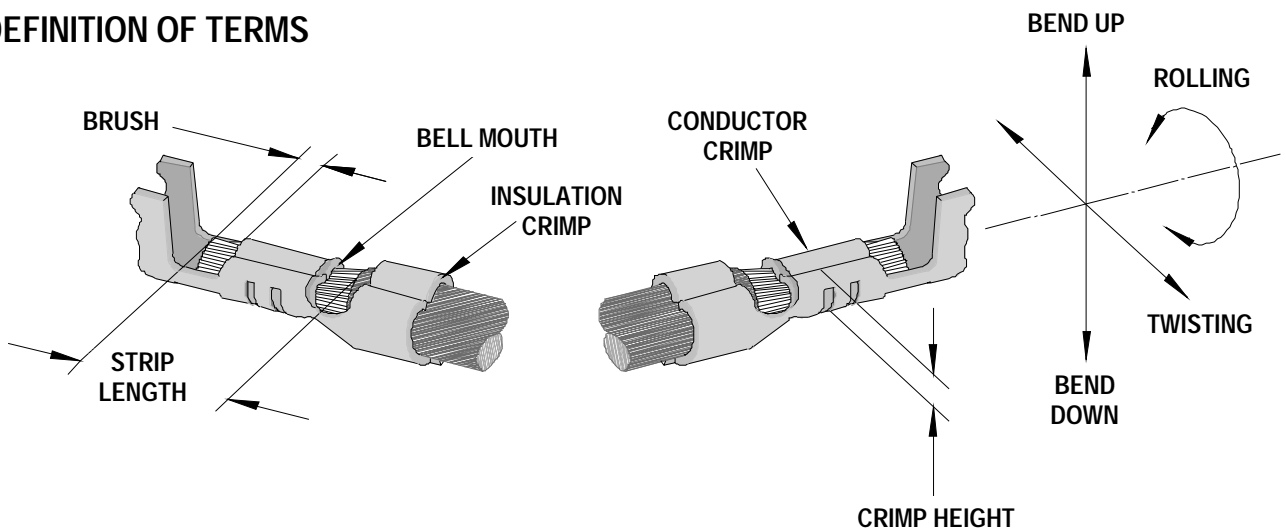

The above terminal drawing is a generic terminal representation. It is not an image of a terminal listed in the scope.

Hand Crimp Tool for .100 KK

CONDITIONS:

After crimping, the conductor profiles should measure the following (see notes on page 5).

Terminal Series No.	Wire Size		Cond. Crimp Height (REF)		Cond. Crimp Width		Pull Force Min.		Profile	
	AWG	mm ²	mm	In.	mm	In.	N	Lb.	A	B
1854	24	0.20	0.76-0.86	.030-.034	1.40	.055	28.9	6.50	X	
1854	26	0.12	0.71-0.81	.028-.032	1.40	.055	17.8	4.00		X
1854	28	0.08	0.69-0.79	.027-.031	1.40	.055	11.1	2.50		X
1854	30	0.05	0.69-0.79	.027-.031	1.40	.055	6.7	1.50		X
1855	24	0.20	0.76-0.86	.030-.034	1.40	.055	28.9	6.50	X	
1855	26	0.12	0.71-0.81	.028-.032	1.40	.055	17.8	4.00		X
1855	28	0.08	0.69-0.79	.027-.031	1.40	.055	11.1	2.50		X
1855	30	0.05	0.69-0.79	.027-.031	1.40	.055	6.7	1.50		X
2189	24	0.20	0.76-0.86	.030-.034	1.40	.055	28.9	6.50	X	
2189	26	0.12	0.71-0.81	.028-.032	1.40	.055	17.8	4.00		X
2189	28	0.08	0.69-0.79	.027-.031	1.40	.055	11.1	2.50		X
2189	30	0.05	0.69-0.79	.027-.031	1.40	.055	6.7	1.50		X
2190	24	0.20	0.76-0.86	.030-.034	1.40	.055	28.9	6.50	X	
2190	26	0.12	0.71-0.81	.028-.032	1.40	.055	17.8	4.00		X
2190	28	0.08	0.69-0.79	.027-.031	1.40	.055	11.1	2.50		X
2190	30	0.05	0.69-0.79	.027-.031	1.40	.055	6.7	1.50		X
2717	24	0.20	0.76-0.86	.030-.034	1.40	.055	28.9	6.50	X	
2717	26	0.12	0.71-0.81	.028-.032	1.40	.055	17.8	4.00		X
2717	28	0.08	0.69-0.79	.027-.031	1.40	.055	11.1	2.50		X
2717	30	0.05	0.69-0.79	.027-.031	1.40	.055	6.7	1.50		X
2759	22	0.35	0.76-0.86	.030-.034	1.40	.055	44.8	10.00	X	
2759	24	0.20	0.76-0.86	.030-.034	1.40	.055	28.9	6.50	X	
2759	26	0.12	0.71-0.81	.028-.032	1.40	.055	17.8	4.00		X
2759	28	0.08	0.69-0.79	.027-.031	1.40	.055	11.1	2.50		X
2759	30	0.05	0.69-0.79	.027-.031	1.40	.055	6.7	1.50		X
2951	24	0.20	0.76-0.86	.030-.034	1.40	.055	28.9	6.50	X	
2951	26	0.12	0.71-0.81	.028-.032	1.40	.055	17.8	4.00		X
2951	28	0.08	0.69-0.79	.027-.031	1.40	.055	11.1	2.50		X
2951	30	0.05	0.69-0.79	.027-.031	1.40	.055	6.7	1.50		X
40445	22	0.35	0.76-0.86	.030-.034	1.40	.055	44.8	10.00	X	
40445	24	0.20	0.76-0.86	.030-.034	1.40	.055	28.9	6.50	X	
40445	26	0.12	0.71-0.81	.028-.032	1.40	.055	17.8	4.00		X
40445	28	0.08	0.69-0.79	.027-.031	1.40	.055	11.1	2.50		X
40445	30	0.05	0.69-0.79	.027-.031	1.40	.055	6.7	1.50		X

Hand Crimp Tool for .100 KK

CONDITIONS: (Continued)

Terminal Series No.	Wire Size		Cond. Crimp Height (REF)		Cond. Crimp Width		Pull Force Min.		Profile	
	AWG	mm ²	mm	In.	mm	In.	N	Lb.	A	B
41572	22	0.35	0.76-0.86	.030-.034	1.40	.055	44.8	10.00	X	
41572	24	0.20	0.76-0.86	.030-.034	1.40	.055	28.9	6.50	X	
41572	26	0.12	0.71-0.81	.028-.032	1.40	.055	17.8	4.00		X
41572	28	0.08	0.69-0.79	.027-.031	1.40	.055	11.1	2.50		X
41572	30	0.05	0.69-0.79	.027-.031	1.40	.055	6.7	1.50		X
4548	24	0.20	0.76-0.86	.030-.034	1.40	.055	28.9	6.50	X	
4548	26	0.12	0.71-0.81	.028-.032	1.40	.055	17.8	4.00		X
4548	28	0.08	0.69-0.79	.027-.031	1.40	.055	11.1	2.50		X
4548	30	0.05	0.69-0.79	.027-.031	1.40	.055	6.7	1.50		X
4559	24	0.20	0.76-0.86	.030-.034	1.40	.055	28.9	6.50	X	
4559	26	0.12	0.71-0.81	.028-.032	1.40	.055	17.8	4.00		X
4559	28	0.08	0.69-0.79	.027-.031	1.40	.055	11.1	2.50		X
4559	30	0.05	0.69-0.79	.027-.031	1.40	.055	6.7	1.50		X
4809	22	0.35	0.76-0.86	.030-.034	1.40	.055	44.8	10.00	X	
4809	24	0.20	0.76-0.86	.030-.034	1.40	.055	28.9	6.50	X	
4809	26	0.12	0.71-0.81	.028-.032	1.40	.055	17.8	4.00		X
4809	28	0.08	0.69-0.79	.027-.031	1.40	.055	11.1	2.50		X
4809	30	0.05	0.69-0.79	.027-.031	1.40	.055	6.7	1.50		X
5159	24	0.20	0.76-0.86	.030-.034	1.40	.055	28.9	6.50	X	
5159	26	0.12	0.71-0.81	.028-.032	1.40	.055	17.8	4.00		X
5159	28	0.08	0.69-0.79	.027-.031	1.40	.055	11.1	2.50		X
5159	30	0.05	0.69-0.79	.027-.031	1.40	.055	6.7	1.50		X
6459	22	0.35	0.76-0.86	.030-.034	1.40	.055	44.8	10.00	X	
6459	24	0.20	0.76-0.86	.030-.034	1.40	.055	28.9	6.50	X	
6459	26	0.12	0.71-0.81	.028-.032	1.40	.055	17.8	4.00		X
6459	28	0.08	0.69-0.79	.027-.031	1.40	.055	11.1	2.50		X
6459	30	0.05	0.69-0.79	.027-.031	1.40	.055	6.7	1.50		X
6796	24	0.20	0.76-0.86	.030-.034	1.40	.055	28.9	6.50	X	
6796	26	0.12	0.71-0.81	.028-.032	1.40	.055	17.8	4.00		X
6796	28	0.08	0.69-0.79	.027-.031	1.40	.055	11.1	2.50		X
6796	30	0.05	0.69-0.79	.027-.031	1.40	.055	6.7	1.50		X
7879	22	0.35	0.76-0.86	.030-.034	1.40	.055	44.8	10.00	X	
7879	24	0.20	0.76-0.86	.030-.034	1.40	.055	28.9	6.50	X	
7879	26	0.12	0.71-0.81	.028-.032	1.40	.055	17.8	4.00		X
7879	28	0.08	0.69-0.79	.027-.031	1.40	.055	11.1	2.50		X
7879	30	0.05	0.69-0.79	.027-.031	1.40	.055	6.7	1.50		X
8088	22	0.35	0.76-0.86	.030-.034	1.40	.055	44.8	10.00	X	
8088	24	0.20	0.76-0.86	.030-.034	1.40	.055	28.9	6.50	X	
8088	26	0.12	0.71-0.81	.028-.032	1.40	.055	17.8	4.00		X
8088	28	0.08	0.69-0.79	.027-.031	1.40	.055	11.1	2.50		X
8088	30	0.05	0.69-0.79	.027-.031	1.40	.055	6.7	1.50		X

Hand Crimp Tool for .100 KK

OPERATION

Open the tool by squeezing the handles together, at the end of the closing stroke, the ratchet mechanism will release the handles, and the hand tool will spring open.

Crimping Terminals

1. Lift the locator blade and place the terminal into the correct die profile (A or B), release the locator blade. Not all tools are equipped with a locator or locator blade.

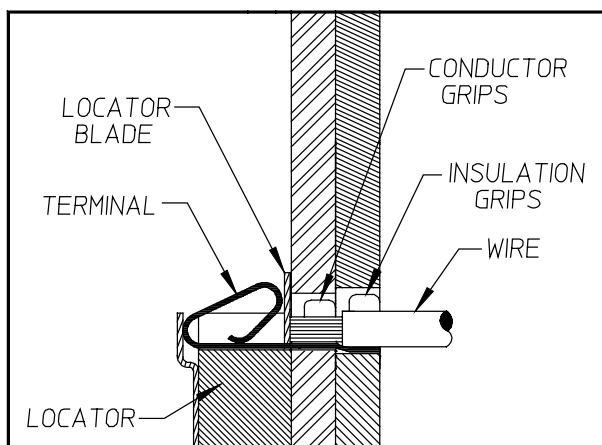

Figure 2

Maintenance

It is recommended that each operator of the tool be made aware of, and responsible for, the following maintenance steps:

1. Remove dust, moisture, and other contaminants with a clean brush, or soft, lint free cloth.
2. Do not use any abrasive materials that could damage the tool.
3. Make certain all pins; pivot points and bearing surfaces are protected with a thin coat of high quality machine oil. Do not oil excessively.
4. When tool is not in use, keep the handles closed to prevent objects from becoming lodged in the crimping dies, and store the tool in a clean, dry area.

Miscrimps or Jams

Should this tool ever become stuck or jammed in a partially closed position, **Do Not force the handles open or closed.** The tool will open easily by lifting the ratchet release lever (See Figure 4).

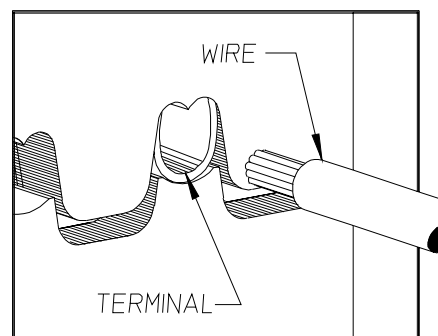

Figure 1

2. Partially close the tool until the terminal is held in place, (See Figure 2).
3. Place a wire into the terminal and up against the locator blade, (See Figure 3). On tools without locators line the wire up with the conductor and insulation grips visually.
4. Close the tool until the ratchet releases, (See Figure 4).
5. Lift the locator blade or wire stop up.
6. Carefully remove the crimped terminal.

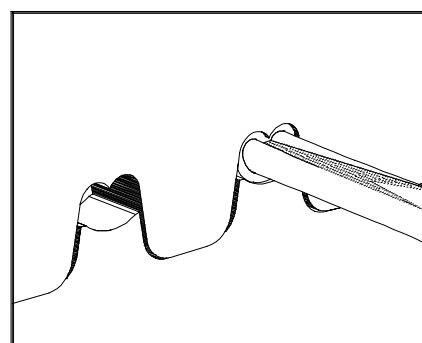

Figure 3

Hand Crimp Tool for .100 KK

How To Adjust Tool Crimp Force (See Figure 4)

It may be necessary over the life of the tool to adjust tool-crimping force. Listed below are the steps required to adjust the crimping force of the hand tool to obtain proper crimp conditions:

1. Remove the screw and washer. Located over the adjustment ring.
2. Lift the adjusting ring slightly, off of the locating pin.
3. Turn the adjusting ring in the desired direction (L= less force, T= more force) to increase or decrease crimp pressure.
4. Press the adjusting wheel flat against the tool and engage the locking pin.
5. Replace the washer and screw.
6. Check the crimp specifications after tool crimp force is adjusted.

Warranty

This tool is for electrical terminal crimping purposes only. This tool is made of the best quality materials. All vital components are long life tested. All tools are warranted to be free of manufacturing defects for a period of **30 days**. Should such a defect occur, we would exchange the tool free of charge. This will not be applicable to altered, misused, or damaged tools. This tool is designed for hand use only. Any clamping, fixturing, or use of handle extensions voids this warranty.

Hand held crimping tools are intended for low volume, prototyping, or repair requirements only.

Caution: Repetitive use of this tool should be

Notes:

1. This tool should only be used for the terminals and wire gauges specified on this sheet.
2. This tool is not adjustable for crimp height, however crimp force is adjustable (See instructions above). Variations in tools, terminals, wire stranding and insulation types may affect crimp height.
3. This tool is intended for standard conductor sizes. It may not give a good insulation crimp support for all insulation sizes.
4. Molex does not repair hand tools (see warranty above) The replacement parts listed are the only parts available for repair. If the handles or crimp tooling is damaged or worn, a new tool must be purchased.
5. Pull force should be used as the final criteria for an acceptable crimp. Pull force is measured with no influence from the insulation crimp. The insulation should be stripped long (1/2 in.) so the insulation grips on the terminal do not grip the wire insulation or the conductor. Refer to Molex Quality Crimping Handbook 63800-0029 for additional information on crimping and crimp testing.
6. Molex does not certify crimp hand tools.

CAUTION: Molex crimp specifications are valid only when used with Molex terminals, applicators and

Hand Crimp Tool for .100 KK

PARTS LIST

Item Number	Order Number	Description	Quantity
1	11-11-0311	Locator Assembly**	1
2	11-11-0324	Spring (Main)	1
3	11-11-0320	Spring (Ratchet)	1

** Not all tools are equipped with a locator or locator blade.

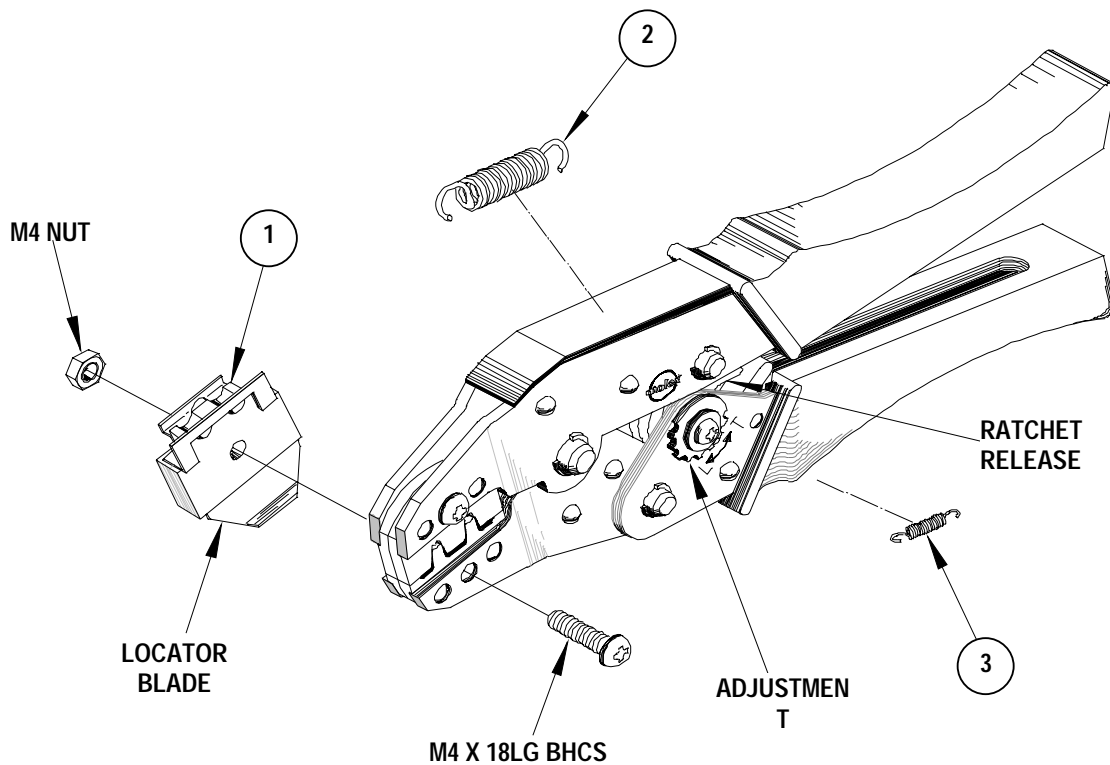

Figure 4

Molex Application Tooling Group

1150 E. Diehl Road
 Naperville, IL, 60563
 Tel: 630-969-4550
 Fax: 630-505-0049

Visit our Web site at <http://www.molex.com>