

Excellent Integrated System Limited

Stocking Distributor

Click to view price, real time Inventory, Delivery & Lifecycle Information:

[ISSI, Integrated Silicon Solution Inc](#)
[IS61C25616AS-25TLI](#)

For any questions, you can email us directly:
sales@integrated-circuit.com



IS61C25616AL IS61C25616AS IS64C25616AL IS64C25616AS

256K x 16 HIGH-SPEED CMOS STATIC RAM

MARCH 2008

FEATURES

HIGH SPEED: (IS61/64C25616AL)

- High-speed access time: 10ns, 12 ns
- Low Active Power: 150 mW (typical)
- Low Standby Power: 10 mW (typical)
CMOS standby

LOW POWER: (IS61/64C25616AS)

- High-speed access time: 25 ns
- Low Active Power: 75 mW (typical)
- Low Standby Power: 1 mW (typical)
CMOS standby
- TTL compatible interface levels
- Single 5V ± 10% power supply
- Fully static operation: no clock or refresh required
- Available in 44-pin SOJ package and 44-pin TSOP (Type II)
- Commercial, Industrial and Automotive temperature ranges available
- Lead-free available

DESCRIPTION

The *ISSI* IS61C25616AL/AS and IS64C25616AL/AS are high-speed, 4,194,304-bit static RAMs organized as 262,144 words by 16 bits. They are fabricated using *ISSI*'s high-performance CMOS technology. This highly reliable process coupled with innovative circuit design techniques, yields access times as fast as 12 ns with low power consumption.

When \overline{CE} is HIGH (deselected), the device assumes a standby mode at which the power dissipation can be reduced down with CMOS input levels.

Easy memory expansion is provided by using Chip Enable and Output Enable inputs, \overline{CE} and \overline{OE} . The active LOW Write Enable (\overline{WE}) controls both writing and reading of the memory. A data byte allows Upper Byte (\overline{UB}) and Lower Byte (\overline{LB}) access.

The IS61C25616AL/AS and IS64C25616AL/AS are packaged in the JEDEC standard 44-pin 400-mil SOJ and 44-pin TSOP (Type II).

FUNCTIONAL BLOCK DIAGRAM

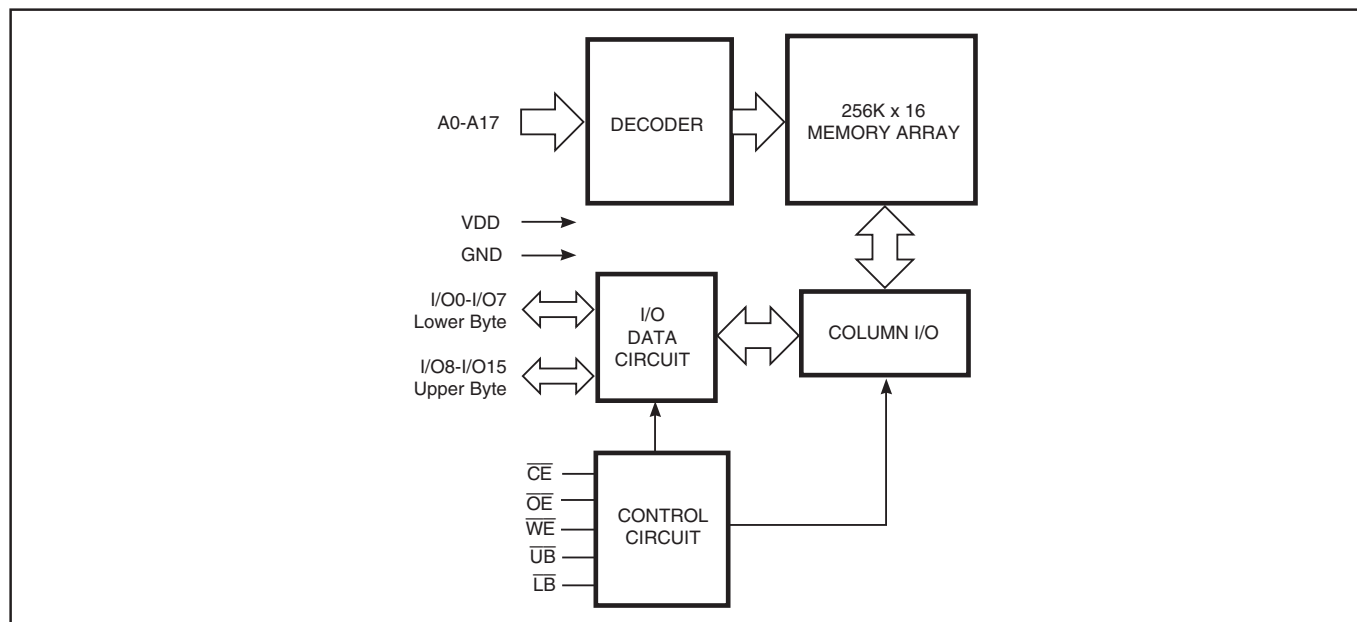

Copyright © 2006 Integrated Silicon Solution, Inc. All rights reserved. ISSI reserves the right to make changes to this specification and its products at any time without notice. ISSI assumes no liability arising out of the application or use of any information, products or services described herein. Customers are advised to obtain the latest version of this device specification before relying on any published information and before placing orders for products.



IS61C25616AL IS61C25616AS
IS64C25616AL IS64C25616AS

PIN CONFIGURATIONS

44-Pin SOJ

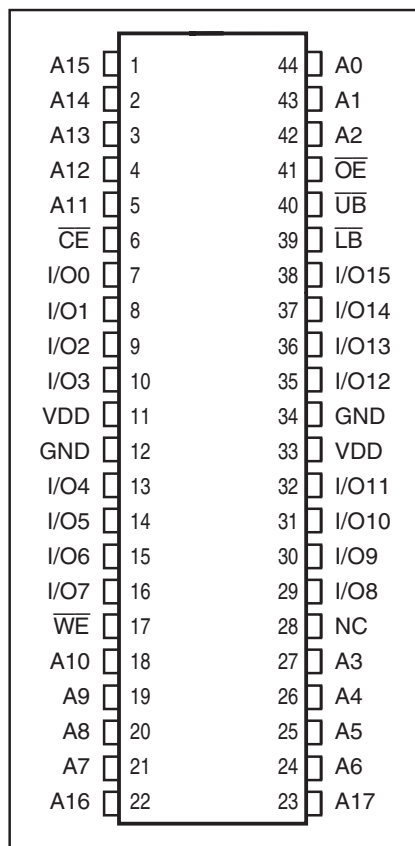

44-Pin TSOP (Type II)

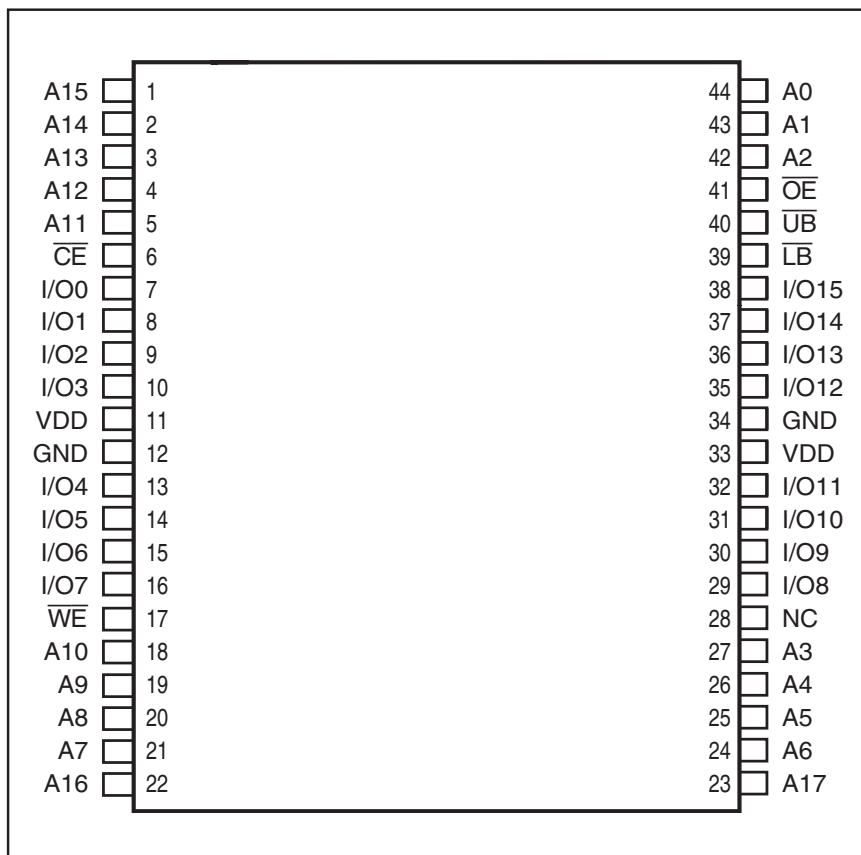

PIN DESCRIPTIONS

A0-A17	Address Inputs
I/O0-I/O15	Data Inputs/Outputs
\overline{CE}	Chip Enable Input
\overline{OE}	Output Enable Input
\overline{WE}	Write Enable Input

\overline{LB}	Lower-byte Control (I/O0-I/O7)
\overline{UB}	Upper-byte Control (I/O8-I/O15)
NC	No Connection
VDD	Power
GND	Ground

IS61C25616AL IS61C25616AS
IS64C25616AL IS64C25616AS
TRUTH TABLE

Mode	\overline{WE}	\overline{CE}	\overline{OE}	\overline{LB}	\overline{UB}	I/O PIN		V _{DD} Current
						I/O0-I/O7	I/O8-I/O15	
Not Selected	X	H	X	X	X	High-Z	High-Z	I _{SB1} , I _{SB2}
Output Disabled	H	L	H	X	X	High-Z	High-Z	I _{CC1} , I _{CC2}
	X	L	X	H	H	High-Z	High-Z	
Read	H	L	L	L	H	D _{OUT}	High-Z	I _{CC1} , I _{CC2}
	H	L	L	H	L	High-Z	D _{OUT}	
	H	L	L	L	L	D _{OUT}	D _{OUT}	
Write	L	L	X	L	H	D _{IN}	High-Z	I _{CC1} , I _{CC2}
	L	L	X	H	L	High-Z	D _{IN}	
	L	L	X	L	L	D _{IN}	D _{IN}	

ABSOLUTE MAXIMUM RATINGS⁽¹⁾

Symbol	Parameter	Value	Unit
V _{TERM}	Terminal Voltage with Respect to GND	-0.5 to +7.0	V
T _{STG}	Storage Temperature	-65 to +150	°C
P _T	Power Dissipation	1.5	W
I _{OUT}	DC Output Current (LOW)	20	mA

Notes:

1. Stress greater than those listed under ABSOLUTE MAXIMUM RATINGS may cause permanent damage to the device. This is a stress rating only and functional operation of the device at these or any other conditions above those indicated in the operational sections of this specification is not implied. Exposure to absolute maximum rating conditions for extended periods may affect reliability.

CAPACITANCE^(1,2)

Symbol	Parameter	Conditions	Max.	Unit
C _{IN}	Input Capacitance	V _{IN} = 0V	5	pF
C _{OUT}	Output Capacitance	V _{OUT} = 0V	7	pF

Notes:

1. Tested initially and after any design or process changes that may affect these parameters.
2. Test conditions: T_A = 25°C, f = 1 MHz, V_{DD} = 5.0V.

DC ELECTRICAL CHARACTERISTICS (Over Operating Range)

Symbol	Parameter	Test Conditions	Min.	Max.	Unit	
V _{OH}	Output HIGH Voltage	V _{DD} = Min., I _{OH} = -4.0 mA	2.4	—	V	
V _{OL}	Output LOW Voltage	V _{DD} = Min., I _{OL} = 8.0 mA	—	0.4	V	
V _{IH}	Input HIGH Voltage		2.2	V _{DD} + 0.5	V	
V _{IL}	Input LOW Voltage ⁽¹⁾		-0.3	0.8	V	
I _{LI}	Input Leakage	GND ≤ V _{IN} ≤ V _{DD}	Com.	-1	1	μA
			Ind.	-2	2	
			Auto.	-5	5	
I _{LO}	Output Leakage	GND ≤ V _{OUT} ≤ V _{DD} Outputs Disabled	Com.	-1	1	μA
			Ind.	-2	2	
			Auto.	-5	5	

Note: 1. V_{IL} = -3.0V for pulse width less than 10 ns.



IS61C25616AL IS61C25616AS
IS64C25616AL IS64C25616AS

OPERATING RANGE: HIGH SPEED OPTION (IS61/64C25616AL)

Range	Ambient Temperature	V _{DD}	Speed (ns)
Commercial	0°C to +70°C	5V ± 10%	10
Industrial	-40°C to +85°C	5V ± 10%	10
Automotive	-40°C to +125°C	5V ± 10%	12

OPERATING RANGE: LOW POWER OPTION (IS61/64C25616AS)

Range	Ambient Temperature	V _{DD}	Speed (ns)
Commercial	0°C to +70°C	5V ± 10%	25
Industrial	-40°C to +85°C	5V ± 10%	25
Automotive	-40°C to +125°C	5V ± 10%	25



IS61C25616AL IS61C25616AS
IS64C25616AL IS64C25616AS

HIGH SPEED OPTION (IS61/64C25616AL)

POWER SUPPLY CHARACTERISTICS⁽¹⁾ (Over Operating Range)

Symbol	Parameter	Test Conditions		-10 ns		-12 ns		Unit
				Min.	Max.	Min.	Max.	
I _{CC1}	V _{DD} Operating Supply Current	V _{DD} = V _{DD MAX.} , $\overline{CE} = V_{IL}$ I _{OUT} = 0 mA, f = 0	Com.	—	45	—	45	mA
			Ind.	—	50	—	50	
			Auto.	—	55	—	55	
I _{CC2}	V _{DD} Dynamic Operating Supply Current	V _{DD} = V _{DD MAX.} , $\overline{CE} = V_{IL}$ I _{OUT} = 0 mA, f = f _{MAX}	Com.	—	50	—	45	mA
			Ind.	—	55	—	50	
			Auto.	—	70	—	60	
			typ. ⁽²⁾	30	25			
I _{SB1}	TTL Standby Current (TTL Inputs)	V _{DD} = V _{DD MAX.} , V _{IN} = V _{IH} or V _{IL} $\overline{CE} \geq V_{IH}$, f = 0	Com.	—	15	—	15	mA
			Ind.	—	20	—	20	
			Auto.	—	30	—	30	
I _{SB2}	CMOS Standby Current (CMOS Inputs)	V _{DD} = V _{DD MAX.} , $\overline{CE} \leq V_{DD} - 0.2V$, V _{IN} \geq V _{DD} - 0.2V, or V _{IN} \leq 0.2V, f = 0	Com.	—	8	—	8	mA
			Ind.	—	12	—	12	
			Auto.	—	20	—	20	
			typ. ⁽²⁾	2				

Note:

- At f = f_{MAX}, address and data inputs are cycling at the maximum frequency, f = 0 means no input lines change.
- Typical values are measured at V_{DD} = 5V, T_A = 25°C and not 100% tested.

LOW POWER OPTION (IS61/64C25616AS)

POWER SUPPLY CHARACTERISTICS⁽¹⁾ (Over Operating Range)

Symbol	Parameter	Test Conditions		-25 ns		Unit
				Min.	Max.	
I _{CC}	Average operating Current	$\overline{CE} = V_{IL}$, V _{DD} = Max., I _{OUT} = 0 mA, f = 0	Com.	—	10	mA
			Ind.	—	15	
			Auto.	—	20	
I _{CC1}	V _{DD} Dynamic Operating Supply Current	V _{DD} = Max., $\overline{CE} = V_{IL}$ I _{OUT} = 0 mA, f = f _{MAX} V _{IN} = V _{IH} or V _{IL}	Com.	—	25	mA
			Ind.	—	30	
			Auto.	—	40	
			typ. ⁽²⁾	15		
I _{SB1}	TTL Standby Current (TTL Inputs)	V _{DD} = Max., V _{IN} = V _{IH} or V _{IL} , $\overline{CE} \geq V_{IH}$, f = 0	Com.	—	1	mA
			Ind.	—	1.5	
			Auto.	—	2	
I _{SB2}	CMOS Standby Current (CMOS Inputs)	V _{DD} = Max., $\overline{CE} \geq V_{DD} - 0.2V$, V _{IN} \geq V _{DD} - 0.2V, or V _{IN} \leq V _{SS} + 0.2V, f = 0	Com.	—	0.8	mA
			Ind.	—	0.9	
			Auto.	—	2	
			typ. ⁽²⁾	0.2		

Note:

- At f = f_{MAX}, address and data inputs are cycling at the maximum frequency, f = 0 means no input lines change.
- Typical values are measured at V_{DD} = 5V, T_A = 25°C and not 100% tested.

IS61C25616AL IS61C25616AS
IS64C25616AL IS64C25616AS

READ CYCLE SWITCHING CHARACTERISTICS⁽¹⁾ (Over Operating Range)

Symbol	Parameter	-10		-12		-25		Unit
		Min.	Max.	Min.	Max.	Min.	Max.	
t _{RC}	Read Cycle Time	10	—	12	—	25	—	ns
t _{AA}	Address Access Time	—	10	—	12	—	25	ns
t _{OHA}	Output Hold Time	3	—	3	—	3	—	ns
t _{ACE}	\overline{CE} Access Time	—	10	—	12	—	25	ns
t _{DOE}	\overline{OE} Access Time	—	5	—	6	—	15	ns
t _{HZOE⁽²⁾}	\overline{OE} to High-Z Output	0	5	0	6	0	8	ns
t _{LZOE⁽²⁾}	\overline{OE} to Low-Z Output	0	—	0	—	2	—	ns
t _{HZCE⁽²⁾}	\overline{CE} to High-Z Output	0	5	0	6	0	8	ns
t _{LZCE⁽²⁾}	\overline{CE} to Low-Z Output	2	—	2	—	2	—	ns
t _{BA}	\overline{LB} , \overline{UB} Access Time	—	5	—	6	—	25	ns
t _{HZB}	\overline{LB} , \overline{UB} to High-Z Output	0	5	0	6	0	8	ns
t _{LZB}	\overline{LB} , \overline{UB} to Low-Z Output	0	—	0	—	0	—	ns

Notes:

1. Test conditions assume signal transition times of 3 ns or less, timing reference levels of 1.5V, input pulse levels of 0 to 3.0V and output loading specified in Figure 1.
2. Tested with the load in Figure 2. Transition is measured ± 500 mV from steady-state voltage. Not 100% tested.
3. Not 100% tested.

AC TEST CONDITIONS

Parameter	Unit
Input Pulse Level	0V to 3.0V
Input Rise and Fall Times	3 ns
Input and Output Timing and Reference Level	1.5V
Output Load	See Figures 1 and 2

AC TEST LOADS

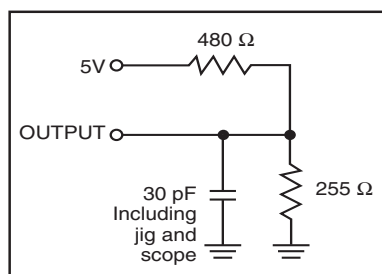

Figure 1

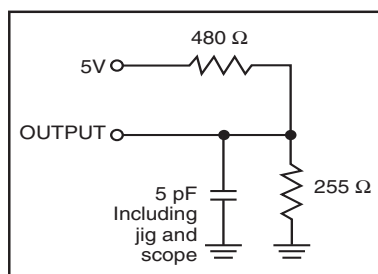
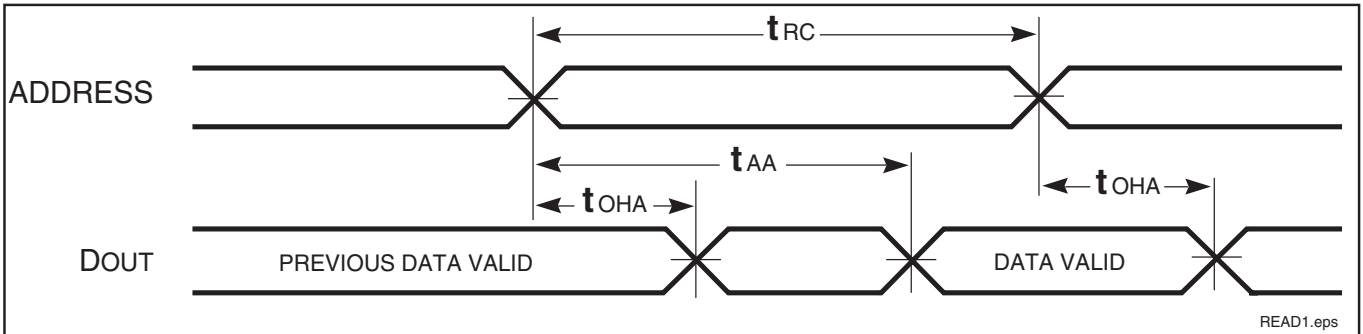

Figure 2

IS61C25616AL IS61C25616AS
IS64C25616AL IS64C25616AS

AC WAVEFORMS

READ CYCLE NO. 1^(1,2) (Address Controlled) ($\overline{CE} = \overline{OE} = V_{IL}$, \overline{UB} or $\overline{LB} = V_{IL}$)



READ CYCLE NO. 2^(1,3)

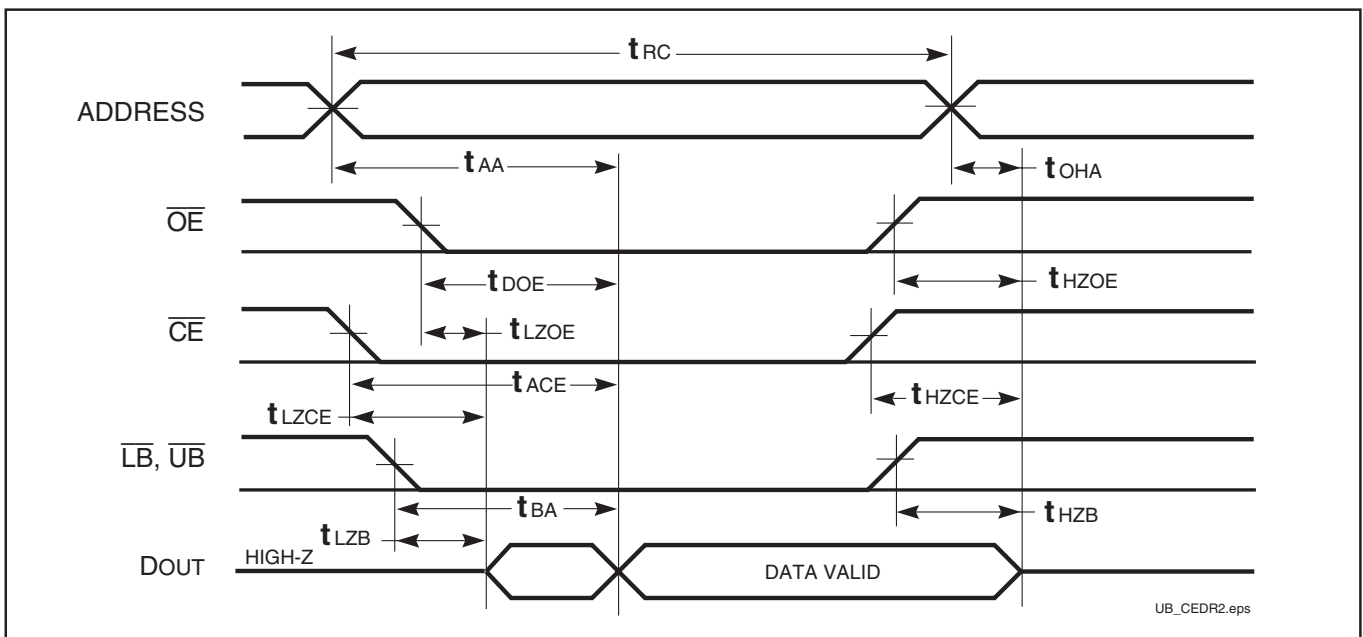

Notes:

1. \overline{WE} is HIGH for a Read Cycle.
2. The device is continuously selected. \overline{OE} , \overline{CE} , \overline{UB} , or $\overline{LB} = V_{IL}$.
3. Address is valid prior to or coincident with \overline{CE} LOW transition.



IS61C25616AL IS61C25616AS
IS64C25616AL IS64C25616AS

WRITE CYCLE SWITCHING CHARACTERISTICS^(1,3) (Over Operating Range)

Symbol	Parameter	-10		-12		-25		Unit
		Min.	Max.	Min.	Max.	Min.	Max.	
t _{WC}	Write Cycle Time	10	—	12	—	25	—	ns
t _{SCE}	\overline{CE} to Write End	7	—	9	—	18	—	ns
t _{AW}	Address Setup Time to Write End	7	—	9	—	18	—	ns
t _{HA}	Address Hold from Write End	0	—	0	—	0	—	ns
t _{SA}	Address Setup Time	0	—	0	—	0	—	ns
t _{PWB}	\overline{LB} , \overline{UB} Valid to End of Write	7	—	9	—	18	—	ns
t _{PWE1}	\overline{WE} Pulse Width (\overline{OE} =High)	7	—	9	—	15	—	ns
t _{PWE2}	\overline{WE} Pulse Width (\overline{OE} =Low)	7	—	9	—	17	—	ns
t _{SD}	Data Setup to Write End	6	—	6	—	15	—	ns
t _{HD}	Data Hold from Write End	0	—	0	—	0	—	ns
t _{HZWE} ⁽²⁾	\overline{WE} LOW to High-Z Output	—	6	—	6	—	15	ns
t _{LZWE} ⁽²⁾	\overline{WE} HIGH to Low-Z Output	3	—	3	—	5	—	ns

Notes:

1. Test conditions assume signal transition times of 3 ns or less, timing reference levels of 1.5V, input pulse levels of 0 to 3.0V and output loading specified in Figure 1.
2. Tested with the load in Figure 2. Transition is measured ± 500 mV from steady-state voltage. Not 100% tested.
3. The internal write time is defined by the overlap of \overline{CE} LOW and \overline{UB} or \overline{LB} , and \overline{WE} LOW. All signals must be in valid states to initiate a Write, but any one can go inactive to terminate the Write. The Data Input Setup and Hold timing are referenced to the rising or falling edge of the signal that terminates the write.

IS61C25616AL IS61C25616AS
IS64C25616AL IS64C25616AS

AC WAVEFORMS

WRITE CYCLE NO. 1 (\overline{WE} Controlled)^(1,2)

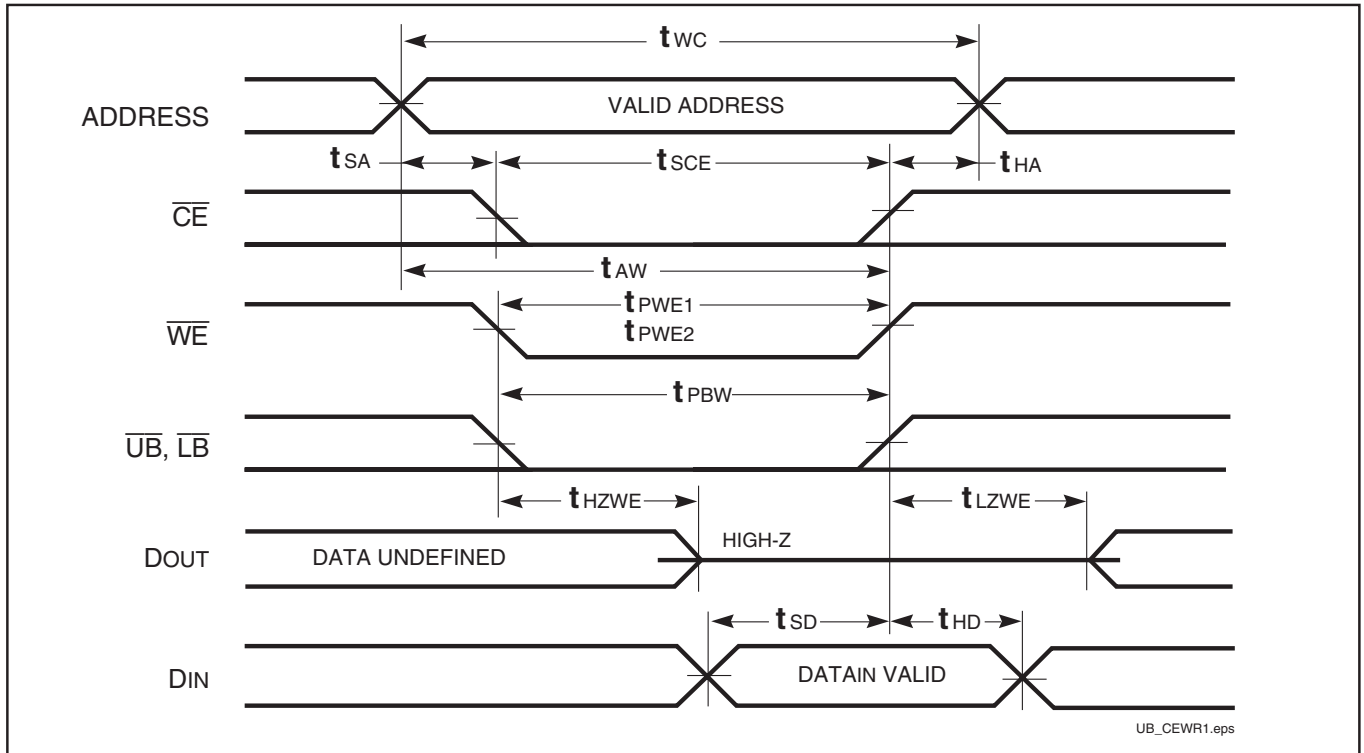

Notes:

1. WRITE is an internally generated signal asserted during an overlap of the LOW states on the \overline{CE} and \overline{WE} inputs and at least one of the \overline{LB} and \overline{UB} inputs being in the LOW state.
2. WRITE = (\overline{CE}) [(\overline{LB}) = (\overline{UB})] (\overline{WE}).

IS61C25616AL IS61C25616AS
IS64C25616AL IS64C25616AS

WRITE CYCLE NO. 2 (\overline{OE} is HIGH During Write Cycle) ^(1,2)

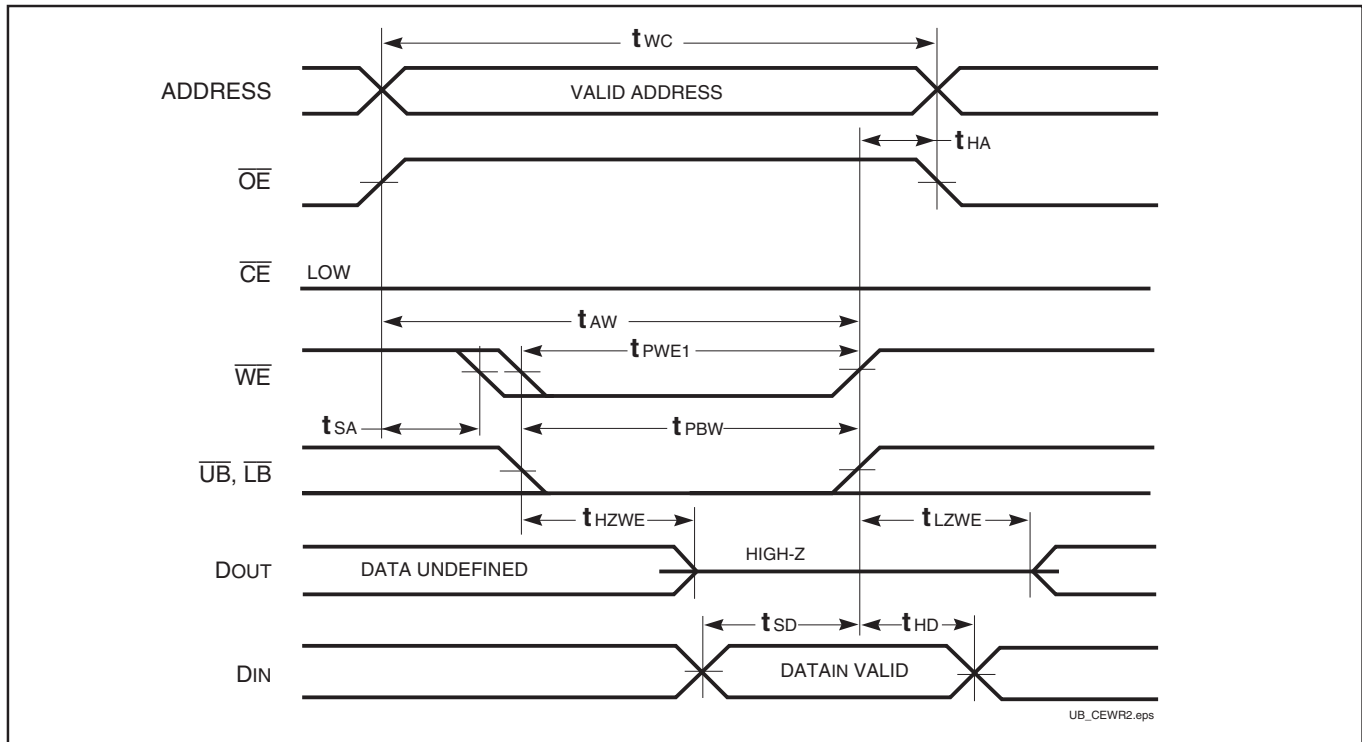

WRITE CYCLE NO. 3 (\overline{OE} is LOW During Write Cycle) ⁽¹⁾

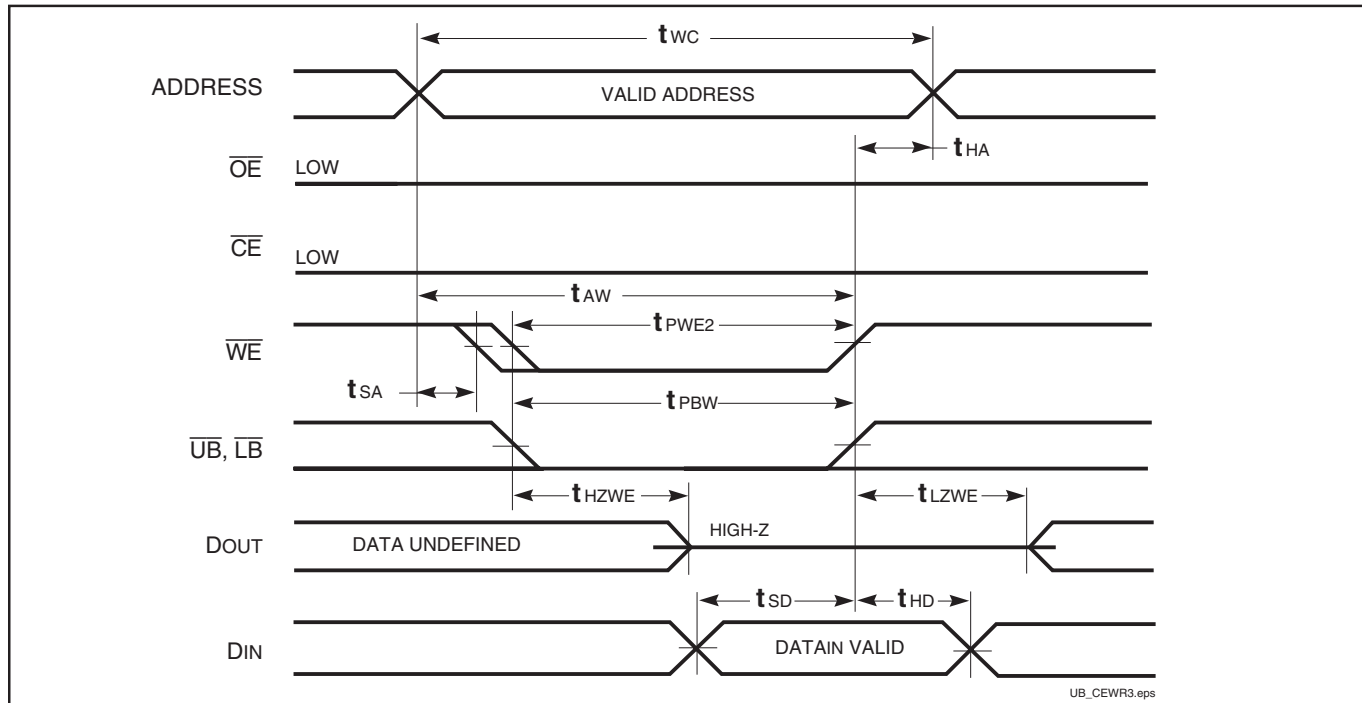

Notes:

1. The internal write time is defined by the overlap of \overline{CE} LOW and \overline{WE} LOW. All signals must be in valid states to initiate a Write, but any one can go inactive to terminate the Write. The Data Input Setup and Hold timing are referenced to the rising or falling edge of the signal that terminates the Write.
2. I/O will assume the High-Z state if $\overline{OE} \geq V_{IH}$.



IS61C25616AL IS61C25616AS
IS64C25616AL IS64C25616AS

WRITE CYCLE NO. 4 ($\overline{UB}/\overline{LB}$ Back to Back Write)

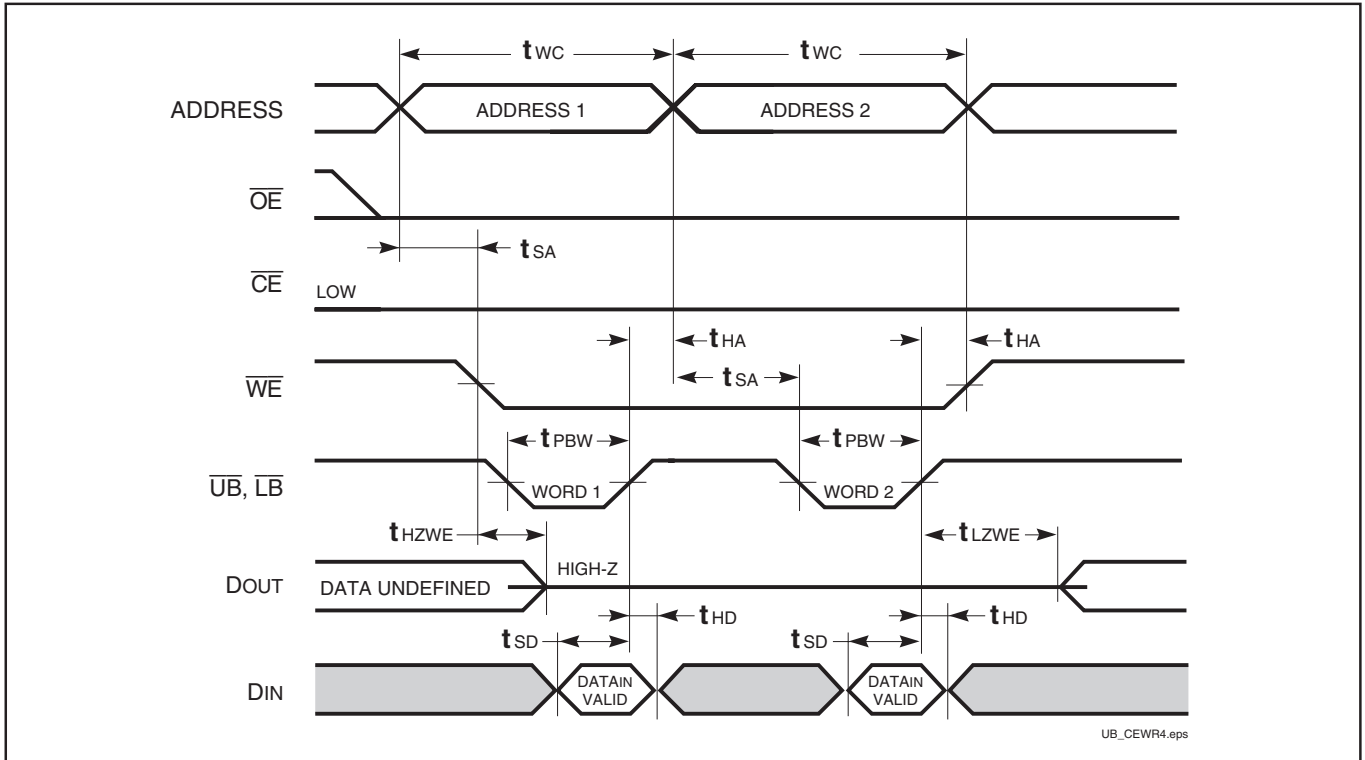



IS61C25616AL IS61C25616AS
IS64C25616AL IS64C25616AS

DATA RETENTION SWITCHING CHARACTERISTICS (HIGH SPEED) (IS61/64C25616AL)

Symbol	Parameter	Test Condition	Min.	Max.	Unit
V_{DR}	V_{DD} for Data Retention	See Data Retention Waveform	2.9	5.5	V
I_{DR}	Data Retention Current	$V_{DD} = 2.9V, \overline{CE} \geq V_{DD} - 0.2V$ $V_{IN} \geq V_{DD} - 0.2V$, or $V_{IN} \leq V_{SS} + 0.2V$	Com. Ind. Auto. typ. ⁽¹⁾	— — — 1	8 10 15 mA
t_{SDR}	Data Retention Setup Time	See Data Retention Waveform	0	—	ns
t_{RDR}	Recovery Time	See Data Retention Waveform	t_{RC}	—	ns

Note:

1. Typical Values are measured at $V_{DD} = 5V, T_A = 25^\circ C$ and not 100% tested.

DATA RETENTION WAVEFORM (\overline{CE} Controlled)

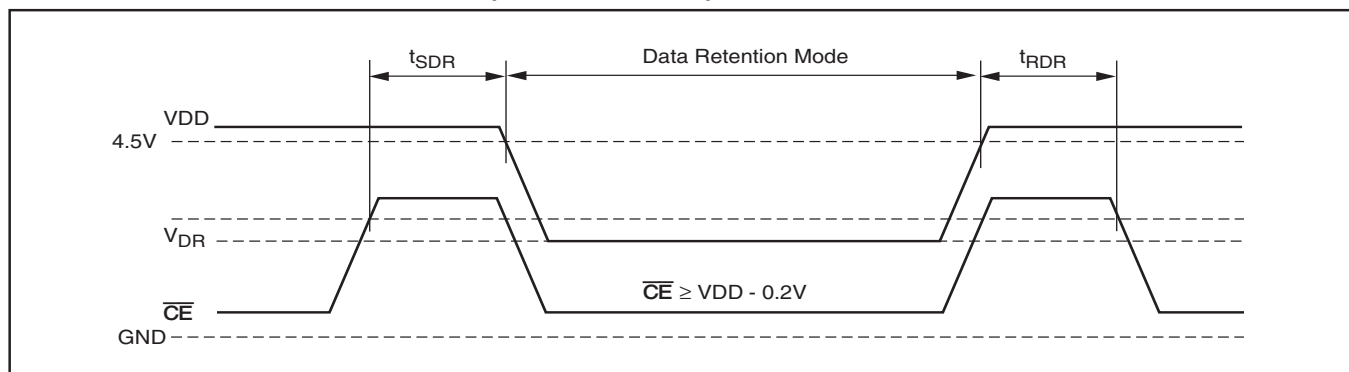



IS61C25616AL IS61C25616AS
IS64C25616AL IS64C25616AS

DATA RETENTION SWITCHING CHARACTERISTICS (LOW POWER) (IS61/64C25616AS)

Symbol	Parameter	Test Condition	Min.	Max.	Unit
V_{DR}	V_{DD} for Data Retention	See Data Retention Waveform	2.9	5.5	V
I_{DR}	Data Retention Current	$V_{DD}=2.9V, \overline{CE} \geq V_{DD}-0.2V$ $V_{IN} \geq V_{DD} - 0.2V, \text{ or } V_{IN} \leq V_{SS} + 0.2V$	—	0.8	mA
		Com.	—	0.9	
		Ind. Auto. typ. ⁽¹⁾	—	2	
t_{SDR}	Data Retention Setup Time	See Data Retention Waveform	0	—	ns
t_{RDR}	Recovery Time	See Data Retention Waveform	t_{RC}	—	ns

Note:

1. Typical Values are measured at $V_{DD}=5V, T_A=25^\circ C$ and not 100% tested.

DATA RETENTION WAVEFORM (\overline{CE} Controlled)

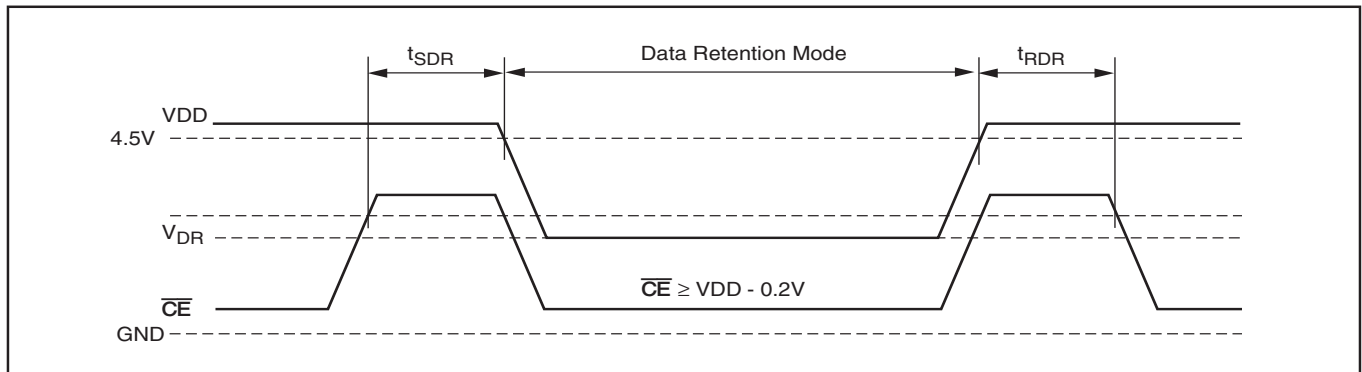



IS61C25616AL IS61C25616AS
IS64C25616AL IS64C25616AS

HIGH SPEED

ORDERING INFORMATION: IS61/64C25616AL

Commercial Range: 0°C to +70°C

Speed (ns)	Order Part No.	Package
10	IS61C25616AL-10TL	44-pin TSOP-II, Lead-free

Industrial Range: -40°C to +85°C

Speed (ns)	Order Part No.	Package
10	IS61C25616AL-10KI	400-mil Plastic SOJ
	IS61C25616AL-10KLI	400-mil Plastic SOJ, Lead-free
	IS61C25616AL-10TI	44-pin TSOP-II
	IS61C25616AL-10TLI	44-pin TSOP-II, Lead-free

Automotive Range: -40°C to +125°C

Speed (ns)	Order Part No.	Package
12	IS64C25616AL-12KA3	400-mil Plastic SOJ
	IS64C25616AL-12TA3	44-pin TSOP-II
	IS64C25616AL-12CTLA3	44-pin TSOP-II, Lead-free, Copper Leadframe

LOW POWER

ORDERING INFORMATION: IS61C25616AS

Industrial Range: -40°C to +85°C

Speed (ns)	Order Part No.	Package
25	IS61C25616AS-25KI	400-mil Plastic SOJ
	IS61C25616AS-25KLI	400-mil Plastic SOJ, Lead-free
	IS61C25616AS-25TI	44-pin TSOP-II
	IS61C25616AS-25TLI	44-pin TSOP-II, Lead-free

Automotive Range: -40°C to +125°C

Speed (ns)	Order Part No.	Package
25	IS64C25616AS-25TLA3	44-pin TSOP-II, Lead-free

PACKAGING INFORMATION

400-mil Plastic SOJ

Package Code: K

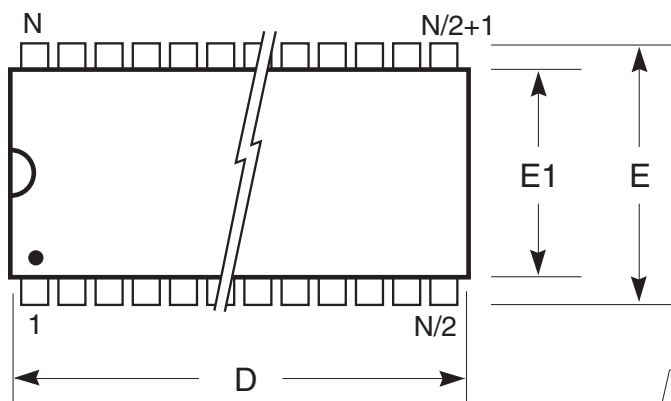

Notes:

1. Controlling dimension: millimeters.
2. BSC = Basic lead spacing between centers.
3. Dimensions D and E1 do not include mold flash protrusions and should be measured from the bottom of the package.
4. Reference document: JEDEC MS-027.

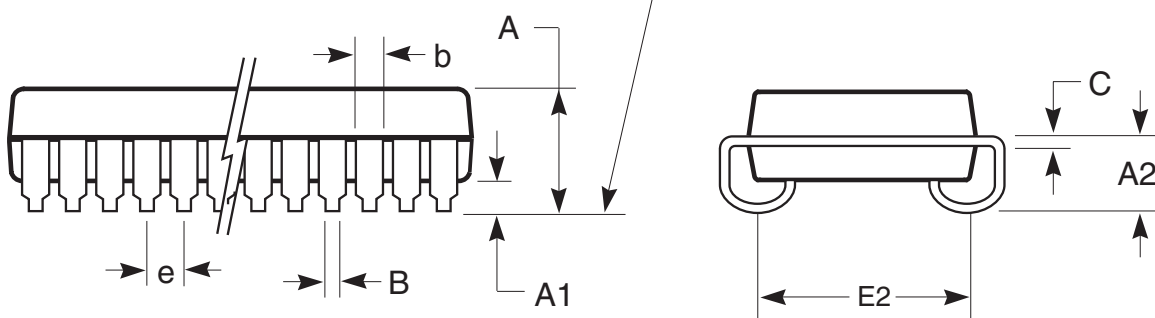

Symbol	Millimeters		Inches		Millimeters		Inches		Millimeters		Inches	
	Min	Max	Min	Max	Min	Max	Min	Max	Min	Max	Min	Max
No. Leads (N)	28				32				36			
A	3.25	3.75	0.128	0.148	3.25	3.75	0.128	0.148	3.25	3.75	0.128	0.148
A1	0.64	—	0.025	—	0.64	—	0.025	—	0.64	—	0.025	—
A2	2.08	—	0.082	—	2.08	—	0.082	—	2.08	—	0.082	—
B	0.38	0.51	0.015	0.020	0.38	0.51	0.015	0.020	0.38	0.51	0.015	0.020
b	0.66	0.81	0.026	0.032	0.66	0.81	0.026	0.032	0.66	0.81	0.026	0.032
C	0.18	0.33	0.007	0.013	0.18	0.33	0.007	0.013	0.18	0.33	0.007	0.013
D	18.29	18.54	0.720	0.730	20.82	21.08	0.820	0.830	23.37	23.62	0.920	0.930
E	11.05	11.30	0.435	0.445	11.05	11.30	0.435	0.445	11.05	11.30	0.435	0.445
E1	10.03	10.29	0.395	0.405	10.03	10.29	0.395	0.405	10.03	10.29	0.395	0.405
E2	9.40 BSC		0.370 BSC		9.40 BSC		0.370 BSC		9.40 BSC		0.370 BSC	
e	1.27 BSC		0.050 BSC		1.27 BSC		0.050 BSC		1.27 BSC		0.050 BSC	

Copyright © 2003 Integrated Silicon Solution, Inc. All rights reserved. ISSI reserves the right to make changes to this specification and its products at any time without notice. ISSI assumes no liability arising out of the application or use of any information, products or services described herein. Customers are advised to obtain the latest version of this device specification before relying on any published information and before placing orders for products.

Integrated Silicon Solution, Inc. — www.issi.com — 1-800-379-4774

Rev. F
10/29/03



PACKAGING INFORMATION

Symbol	Millimeters		Inches		Millimeters		Inches		Millimeters		Inches	
	Min	Max	Min	Max	Min	Max	Min	Max	Min	Max	Min	Max
No. Leads (N)	40				42				44			
A	3.25	3.75	0.128	0.148	3.25	3.75	0.128	0.148	3.25	3.75	0.128	0.148
A1	0.64	—	0.025	—	0.64	—	0.025	—	0.64	—	0.025	—
A2	2.08	—	0.082	—	2.08	—	0.082	—	2.08	—	0.082	—
B	0.38	0.51	0.015	0.020	0.38	0.51	0.015	0.020	0.38	0.51	0.015	0.020
b	0.66	0.81	0.026	0.032	0.66	0.81	0.026	0.032	0.66	0.81	0.026	0.032
C	0.18	0.33	0.007	0.013	0.18	0.33	0.007	0.013	0.18	0.33	0.007	0.013
D	25.91	26.16	1.020	1.030	27.18	27.43	1.070	1.080	28.45	28.70	1.120	1.130
E	11.05	11.30	0.435	0.445	11.05	11.30	0.435	0.445	11.05	11.30	0.435	0.445
E1	10.03	10.29	0.395	0.405	10.03	10.29	0.395	0.405	10.03	10.29	0.395	0.405
E2	9.40 BSC		0.370 BSC		9.40 BSC		0.370 BSC		9.40 BSC		0.370 BSC	
e	1.27 BSC		0.050 BSC		1.27 BSC		0.050 BSC		1.27 BSC		0.050 BSC	

Copyright © 2003 Integrated Silicon Solution, Inc. All rights reserved. ISSI reserves the right to make changes to this specification and its products at any time without notice. ISSI assumes no liability arising out of the application or use of any information, products or services described herein. Customers are advised to obtain the latest version of this device specification before relying on any published information and before placing orders for products.

PACKAGING INFORMATION

Plastic TSOP
 Package Code: T (Type II)

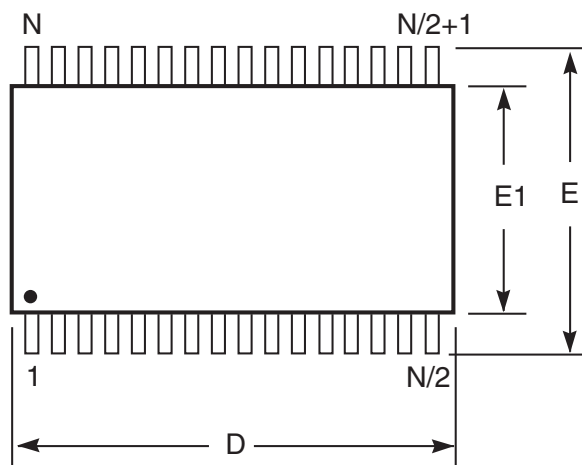

Notes:

1. Controlling dimension: millimeters, unless otherwise specified.
2. BSC = Basic lead spacing between centers.
3. Dimensions D and E1 do not include mold flash protrusions and should be measured from the bottom of the package.
4. Formed leads shall be planar with respect to one another within 0.004 inches at the seating plane.

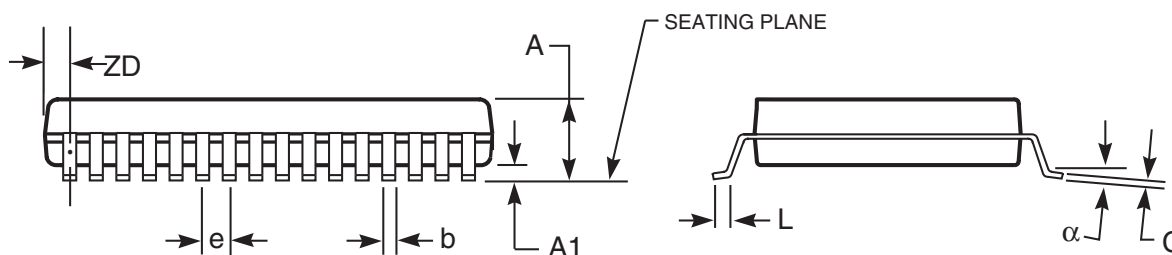

Plastic TSOP (T - Type II)

Symbol	Millimeters		Inches		Millimeters		Inches		Millimeters		Inches	
	Min	Max	Min	Max	Min	Max	Min	Max	Min	Max	Min	Max
Ref. Std.												
No. Leads (N)	32				44				50			
A	—	1.20	—	0.047	—	1.20	—	0.047	—	1.20	—	0.047
A1	0.05	0.15	0.002	0.006	0.05	0.15	0.002	0.006	0.05	0.15	0.002	0.006
b	0.30	0.52	0.012	0.020	0.30	0.45	0.012	0.018	0.30	0.45	0.012	0.018
C	0.12	0.21	0.005	0.008	0.12	0.21	0.005	0.008	0.12	0.21	0.005	0.008
D	20.82	21.08	0.820	0.830	18.31	18.52	0.721	0.729	20.82	21.08	0.820	0.830
E1	10.03	10.29	0.391	0.400	10.03	10.29	0.395	0.405	10.03	10.29	0.395	0.405
E	11.56	11.96	0.451	0.466	11.56	11.96	0.455	0.471	11.56	11.96	0.455	0.471
e	1.27 BSC		0.050 BSC		0.80 BSC		0.032 BSC		0.80 BSC		0.031 BSC	
L	0.40	0.60	0.016	0.024	0.41	0.60	0.016	0.024	0.40	0.60	0.016	0.024
ZD	0.95 REF		0.037 REF		0.81 REF		0.032 REF		0.88 REF		0.035 REF	
α	0°	5°	0°	5°	0°	5°	0°	5°	0°	5°	0°	5°

Copyright © 2003 Integrated Silicon Solution, Inc. All rights reserved. ISSI reserves the right to make changes to this specification and its products at any time without notice. ISSI assumes no liability arising out of the application or use of any information, products or services described herein. Customers are advised to obtain the latest version of this device specification before relying on any published information and before placing orders for products.

Integrated Silicon Solution, Inc. — www.issi.com — 1-800-379-4774

Rev. F
 06/18/03