

Excellent Integrated System Limited

Stocking Distributor

Click to view price, real time Inventory, Delivery & Lifecycle Information:

[E-Switch](#)
[100SP2T2B1M6REH](#)

For any questions, you can email us directly:

sales@integrated-circuit.com

SHEET 1 OF 1

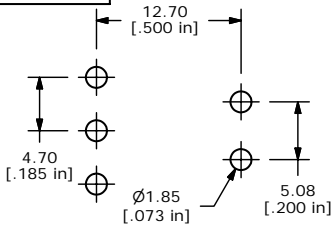

P.C. MOUNTING

SWITCH FUNCTION		
POS. 1	POS. 2	POS. 3
ON	NONE	(ON)
2-3	N/A	2-1

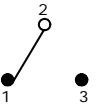

CIRCUIT: SPDT

- NOTE:
- ALL DIMENSIONS IN MM [INCH]
 - GENERAL TOLERANCE: X.X=±0.4
X.XX=±0.25
 - TERMINAL NUMBERS FOR REF ONLY
 - ▲ PLATING MATERIAL: GOLD
 - RATING: 0.4VA MAX @ 20VAC OR DC MAX.
 - ELECTRIC LIFE: 40,000 MAKE-AND-BREAK CYCLES AT FULL LOAD.
 - INSULATION RESISTANCE: 1,000 MEGA-OHM MIN.
 - DIELECTRIC STRENGTH: 1,000 V RMS @SEA LEVEL.
 - OPERATING TEMP.: -30°C to 85°C
 - ▲ DENOTES CRITICAL PARAMETER.
 - 2002/95/EC (ROHS) COMPLIANT.
 - HARDWARE TO BE SHIPPED BULK
 T100000 - HEXNUT - QTY 2
 T100011 - LOCKWASHER - QTY 1
 T100015 - LOCKRING - QTY 1

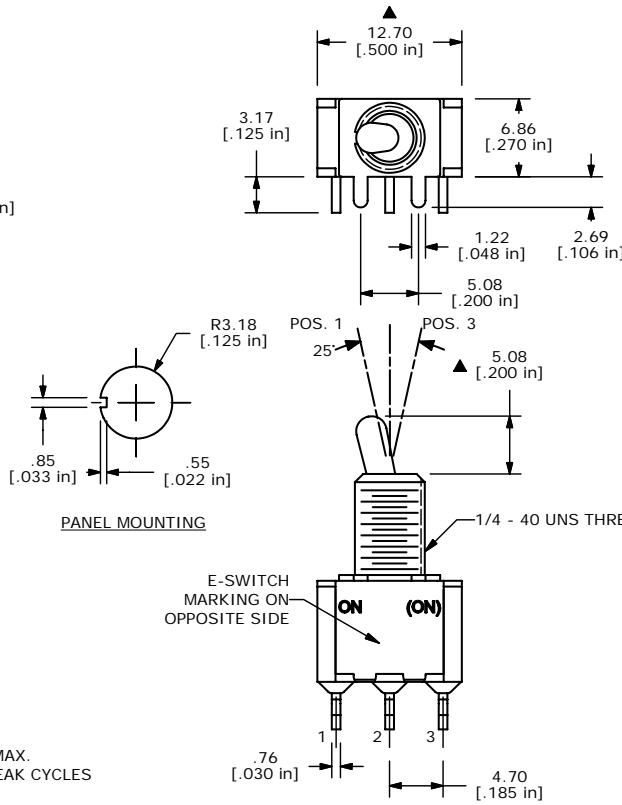

PANEL MOUNTING

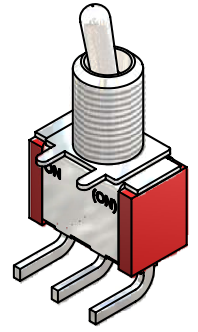

ISOMETRIC

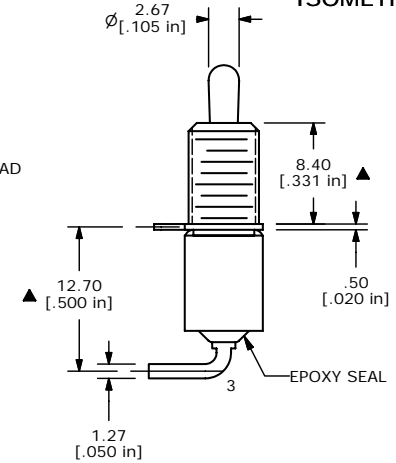

TITLE		100SP2T2B1M6REH	
SCALE	DATE	DR	DWG
2:1	2/2/2007	TN	ST112028
REV		B	

THE INFORMATION CONTAINED IN THIS DOCUMENT IS PROPRIETARY TO E-SWITCH AND IS NOT TO BE COPIED OR TRANSFERRED