

Excellent Integrated System Limited

Stocking Distributor

Click to view price, real time Inventory, Delivery & Lifecycle Information:

[E-Switch](#)
[100SP2T3B3VS2QEH](#)

For any questions, you can email us directly:

sales@integrated-circuit.com

SHEET 1 OF 1

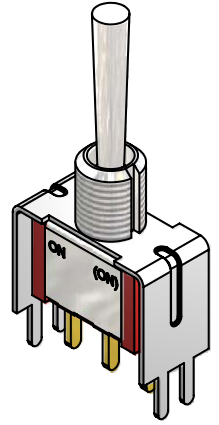
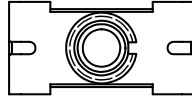
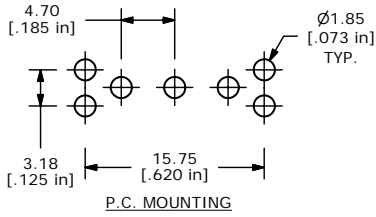

SWITCH FUNCTION		
POS. 1	POS. 2	POS. 3
ON	NONE	(ON)
2-3	N/A	2-1

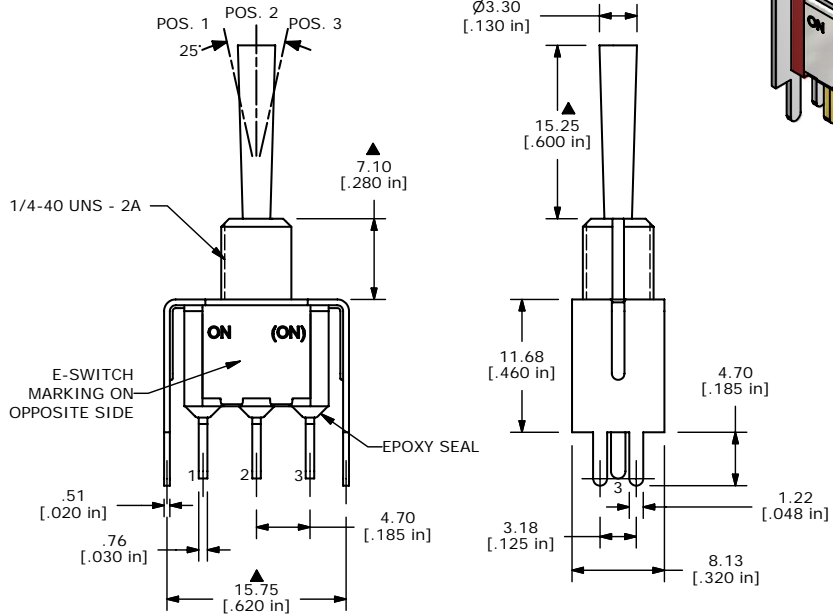
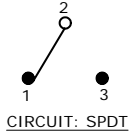

- NOTE:
1. ALL DIMENSIONS IN MM [INCH]
 2. GENERAL TOLERANCE: X.X=±0.4
X.XX=±0.25
 3. TERMINAL NUMBERS FOR REF ONLY
 4. CONTACT MATERIAL: SILVER
 5. RATING: 2A @ 250 VAC
5A @ 120 VAC OR 28 VDC
 6. ELECTRIC LIFE: 40,000 make-and-break cycles at full load.
 7. INSULATION RESISTANCE: 1,000 Mega-ohm min.
 8. DIELECTRIC STRENGTH: 1,000 V RMS @sea level.
 9. OPERATING TEMP.: -30°C to 85°C
 10. ▲ DENOTES CRITICAL PARAMETER.
 11. 2002/95/EC (ROHS) COMPLIANT
 12. HARDWARE TO BE SHIPPED BULK:
T100011 - LOCK WASHER (1)
T100015 - LOCK RING (1)
T100000 - HEX NUT (2)



A	16374	RELEASED FOR PRODUCTION	8/24/06	BO
REV	PCR NO	DESCRIPTION	DATE	BY

TITLE 100SP2T3B3VS2QE				
SCALE 2:1	DATE 8/24/2006	DR BO	DWG ST112001	REV A

THE INFORMATION CONTAINED IN THIS DOCUMENT IS PROPRIETARY TO E-SWITCH AND IS NOT TO BE COPIED OR TRANSFERRED