

Excellent Integrated System Limited

Stocking Distributor

Click to view price, real time Inventory, Delivery & Lifecycle Information:

[E-Switch](#)
[300SP1J4BLKM2QE](#)

For any questions, you can email us directly:

sales@integrated-circuit.com

SHEET 1 OF 1

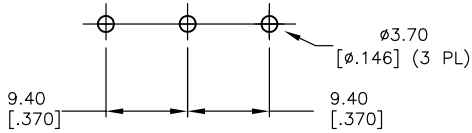

RECOMMENDED PCB LAYOUT
 NOT TO SCALE



CIRCUIT: SPST

SWITCH FUNCTION		
PDS. 1	PDS. 2	PDS. 3
ON	NONE	ON
2-3	OPEN	2-1

NOTES:

- ALL DIMENSIONS IN MM [INCH]
- GENERAL TOLERANCE: X.X=±0.4
X.XX=±0.25
- TERM. NOS. FOR REFERENCE ONLY.
- RATING: 5A @120VAC or 28VDC
2A @250VAC
- MATERIAL: FIXED TERMINAL & MOVING CONTACT
Copper Alloy w/Silver plate
- CONTACT RESISTANCE: 10mILLI Ohms max initial
@2-4VDC, 100mA for AG & AU
- ELECTRICAL LIFE: 50,000 make-and-break
cycles at full load.
- INSULATION RESISTANCE: 1,000M ohm min.
- DIELECTRIC STRENGTH: 1000V RMS @sea level
- OPERATING TEMP.: -30°C to 85°C
- ▲ DENOTES CRITICAL PARAMETER.

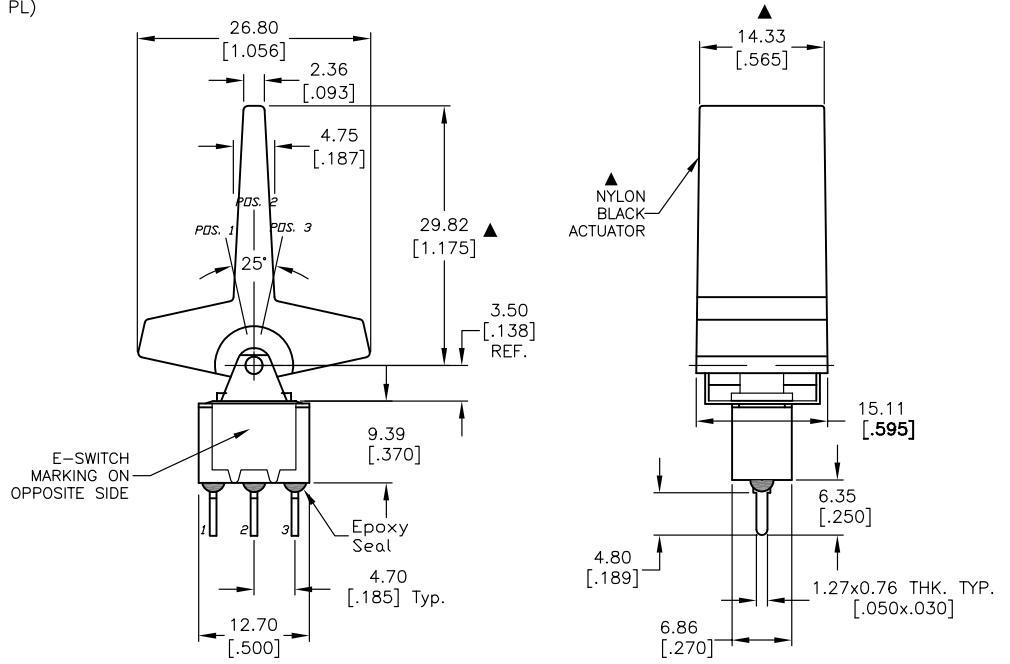

A	13455	RELEASED FOR PRODUCTION	9/16/03	AR
REV.	ECN No.	DESCRIPTION	DATE	CHKD

E-SWITCH®				
TITLE 300SP1J4BLKM2QE				
SCALE	DATE	DR	DWG	REV
1.5:1	9/16/03	AR	T311036	A

THE INFORMATION CONTAINED IN THIS DOCUMENT IS PROPRIETARY TO E-SWITCH AND IS NOT TO BE COPIED OR TRANSFERRED