

Excellent Integrated System Limited

Stocking Distributor

Click to view price, real time Inventory, Delivery & Lifecycle Information:

[E-Switch](#)
[320.01E11ORG](#)

For any questions, you can email us directly:

sales@integrated-circuit.com

SHEET OF

TOP VIEW - SHOW ORIENTATION OF LEGENDS
IN RESPECT TO THE PCB PIN TERMINALS.

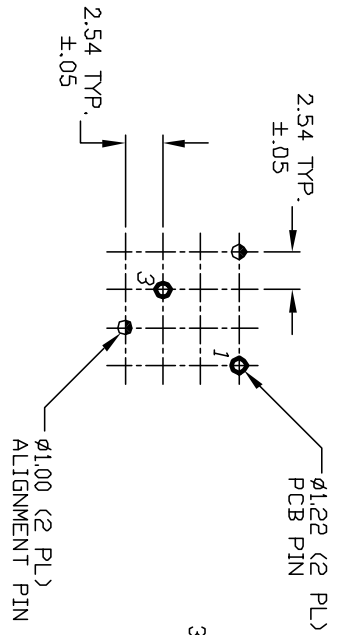

RECOMMENDED P.C.B. LAYOUT

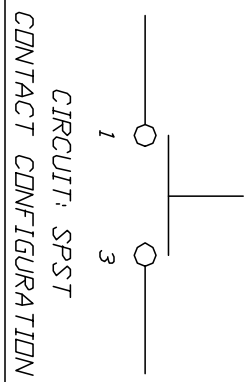
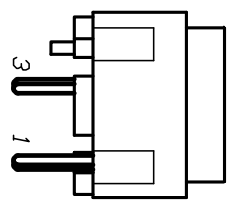
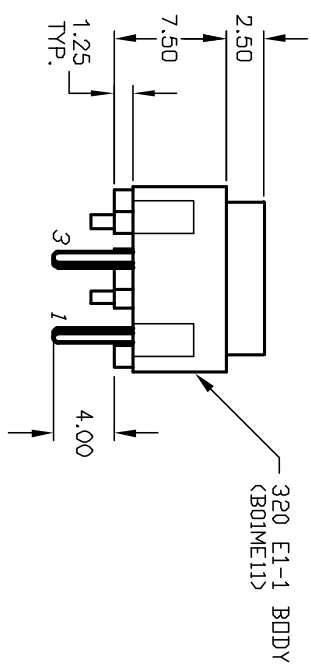
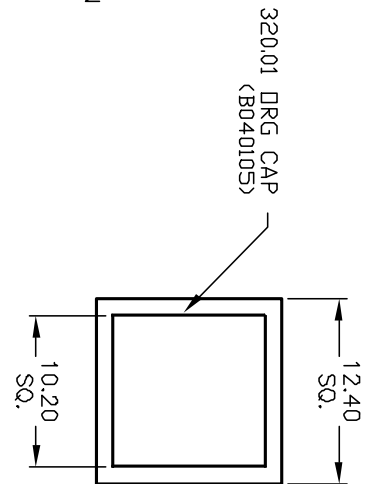

NOTES:

1. ALL DIMENSIONS IN MM
2. GENERAL TOLERANCE: X.X=±0.4
X.XX=±0.25
3. TERMINAL NO'S FOR REFERENCE ONLY.
4. RATING: 25mA, @50VDC
5. OPERATING FORCE: 120gf
6. TRAVEL TO MAKE: 0.7mm

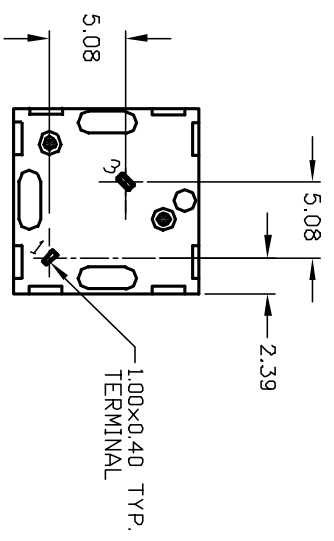

REV.	ECN No.	RELEASED FOR PRODUCTION DESCRIPTION	DATE	CHKD
A	11880	RELEASED FOR PRODUCTION DESCRIPTION	12/27/01	CJB

TITLE	SCALE	DATE	DR	DWG	REV
320.01 E1-1 DRG	2:1	12/27/01	CB	XB0771P	A

E-SWITCH®

THE INFORMATION CONTAINED IN THIS DOCUMENT IS PROPRIETARY TO E-SWITCH AND IS NOT TO BE COPIED OR TRANSMITTED