

## Excellent Integrated System Limited

Stocking Distributor

Click to view price, real time Inventory, Delivery & Lifecycle Information:

[E-Switch](#)  
[320.05E11GRY](#)

For any questions, you can email us directly:

[sales@integrated-circuit.com](mailto:sales@integrated-circuit.com)

SHEET OF

TDP VIEW - SHOW ORIENTATION OF LEGENDS  
IN RESPECT TO THE PCB PIN TERMINALS.

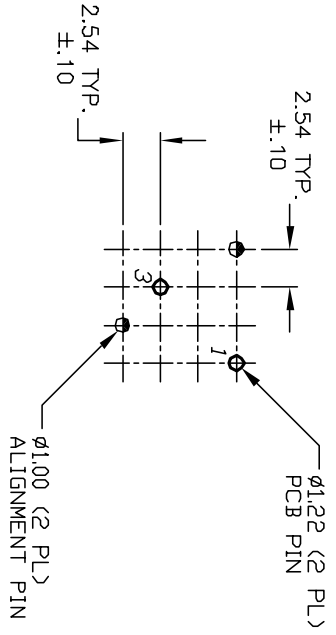

RECOMMENDED P.C.B. LAYOUT

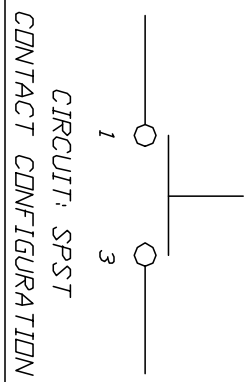
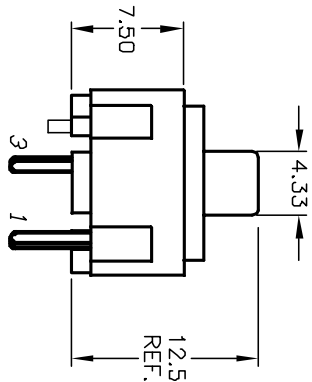
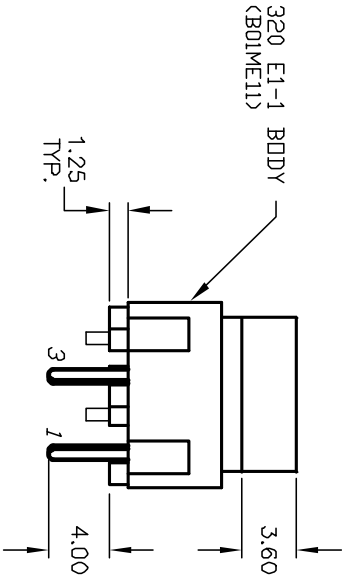
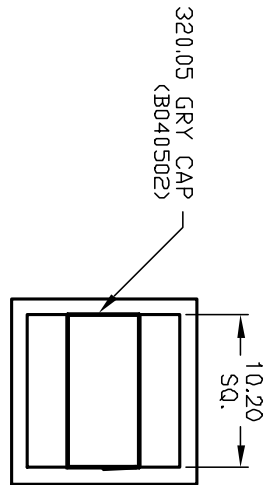

NOTES:

1. ALL DIMENSIONS IN MM
2. GENERAL TOLERANCE: X.X=±0.4  
X.XX=±0.25
3. TERMINAL NO'S FOR REFERENCE ONLY.
4. RATING: 25mA, @50VDC
5. OPERATING FORCE: 120gf
6. TRAVEL TO MAKE: 0.7mm

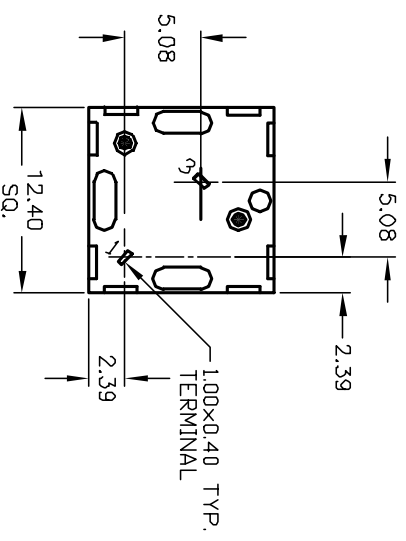

REV.	ECN No.	RELEASED FOR PRODUCTION DESCRIPTION	DATE	CHKD
A	12602	RELEASED FOR PRODUCTION DESCRIPTION	12/4/02	CJB

TITLE	SCALE	DATE	DR	DWG	REV
320.05 E1-1 GRY (Horizontal)	2:1	--	--	XB0488B	A

**E-SWITCH®**

THE INFORMATION CONTAINED IN THIS DOCUMENT IS PROPRIETARY TO E-SWITCH AND IS NOT TO BE COPIED OR TRANSMITTED