

Excellent Integrated System Limited

Stocking Distributor

Click to view price, real time Inventory, Delivery & Lifecycle Information:

[E-Switch](#)
[700DP7B20VS2QE](#)

For any questions, you can email us directly:

sales@integrated-circuit.com

SHEET 1 OF 1

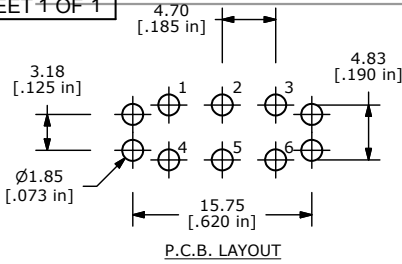

P.C.B. LAYOUT

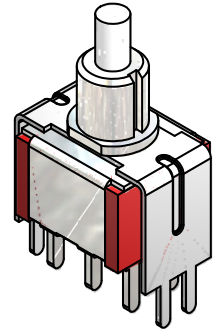
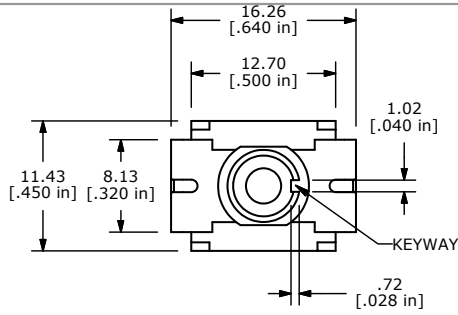

SWITCH FUNCTION	
POS. 1	POS. 2
ON	(ON)
1-3, 4-6	1-2, 4-5

() = MOMENTARY

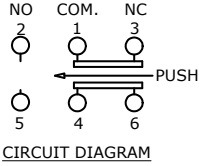

CIRCUIT DIAGRAM

- NOTE:
- ALL DIMENSIONS IN MM [INCH]
 - GENERAL TOLERANCE: X.X=±0.4
X.XX=±0.25
 - TERMINAL NUMBERS FOR REF ONLY
 - CONTACT MATERIAL: SILVER
 - RATING: 1A @ 250 VAC
3A @ 120 VAC OR 28 VDC MAX.
 - ELECTRIC LIFE: 50,000 MAKE-AND-BREAK CYCLES AT FULL LOAD
 - INSULATION RESISTANCE: 1,000 MEGA-OHM MIN.
 - ACTUATION FORCE: 300 ± 100gf
 - TRAVEL: 1.0 ± 0.2mm
 - CONTACT RESISTANCE: 20 mOHM MAX.
TYPICAL @ 2-4 VDC
 - DIELECTRIC STRENGTH: 1,000 V RMS @ SEA LEVEL.
 - OPERATING TEMP.: -30°C to 85°C
 - ▲ DENOTES CRITICAL PARAMETER.
 - 2002/95/EC (ROHS) COMPLIANT.

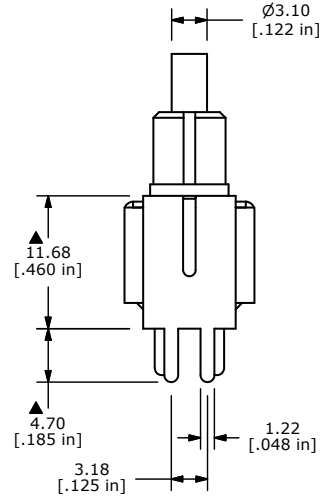
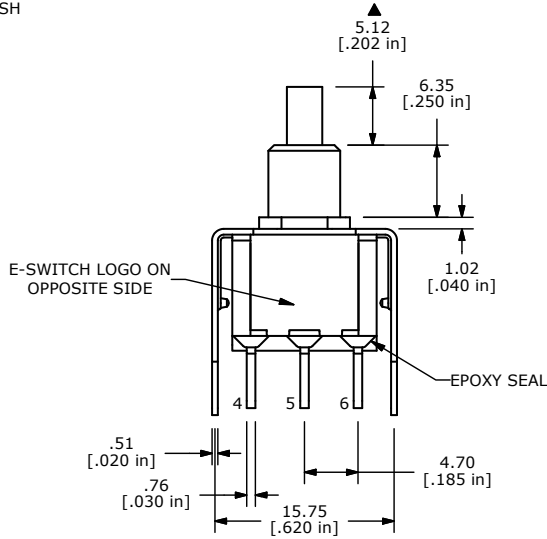

TITLE 700DP7B20VS2QE

B	20055	DRAWING CLEAN-UP / UPDATE	7/11/11	BGL
REV	PCR NO	DESCRIPTION	DATE	BY

THE INFORMATION CONTAINED IN THIS DOCUMENT IS PROPRIETARY TO E-SWITCH AND IS NOT TO BE COPIED OR TRANSFERRED

SCALE 2:1	DATE 7/11/2011	DR BGL	DWG T721013	REV B
-----------	----------------	--------	-------------	-------