

Excellent Integrated System Limited

Stocking Distributor

Click to view price, real time Inventory, Delivery & Lifecycle Information:

[E-Switch](#)
[D16OAT13KREDRED](#)

For any questions, you can email us directly:

sales@integrated-circuit.com

SHEET 1 OF 1

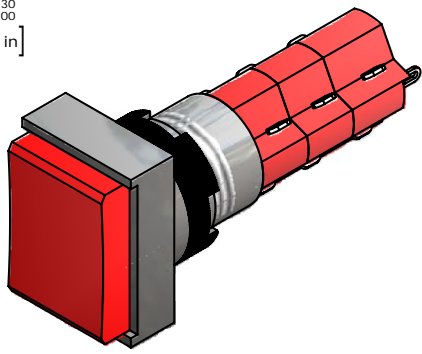
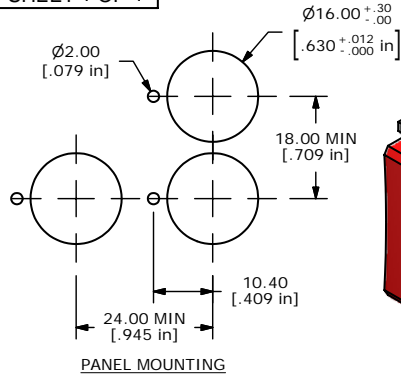

ISOMETRIC

PARTS LIST			
ITEM	QTY	PART NUMBER	DESCRIPTION
1	1	F040036	D16OAT13
2	1	F050423	5000423 24VDC RED LED
3	1	F050204	5000204 TRANSPARENT RED LENS

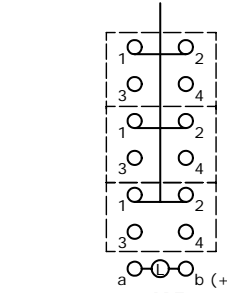

3PDT CONTACT CONFIGURATION

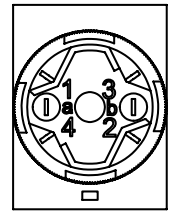
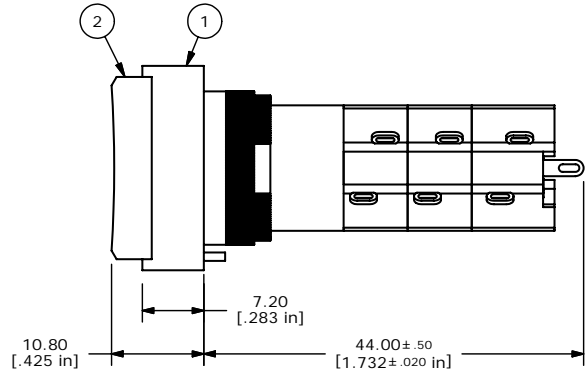
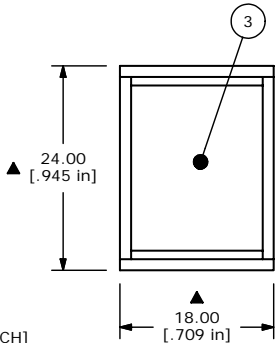

- NOTE:
1. ALL DIMENSIONS IN MM [INCH]
 2. GENERAL TOLERANCE: X.X=±0.4 X.XX=±0.25
 3. TERMINAL NUMBERS FOR REF ONLY
 4. RATING: 5A @ 250 VAC
6A @ 24 VDC
 5. ELECTRIC LIFE: 50,000 MAKE-AND-BREAK CYCLES AT FULL LOAD.
 6. INSULATION RESISTANCE: 1,000 MEGA-OHM MIN.
 7. OPERATING TEMP.: -20°C to 55°C
 - ▲8. LAMP VOLTAGE: 24V DC
 - ▲9. ▲ DENOTES CRITICAL PARAMETER.
 10. 2002/05/EC (ROHS) COMPLIANT.

B	16554	CORRECTED PARTS LIST	10/20/2006	TN
A	16534	RELEASED FOR PRODUCTION	10/19/2006	TN
REV	PCR NO	DESCRIPTION	DATE	BY

THE INFORMATION CONTAINED IN THIS DOCUMENT IS PROPRIETARY TO E-SWITCH AND IS NOT TO BE COPIED OR TRANSFERRED

TITLE D16OAT13KREDRED				
SCALE 1.5:1	DATE 10/19/2006	DR TN	DWG XF0696P	REV B