

## Excellent Integrated System Limited

Stocking Distributor

Click to view price, real time Inventory, Delivery & Lifecycle Information:

[E-Switch](#)  
[KC60A13.001NLS](#)

For any questions, you can email us directly:

[sales@integrated-circuit.com](mailto:sales@integrated-circuit.com)

SHEET 1 OF 1

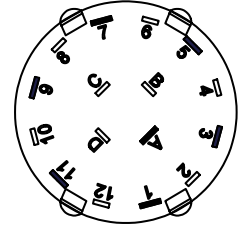
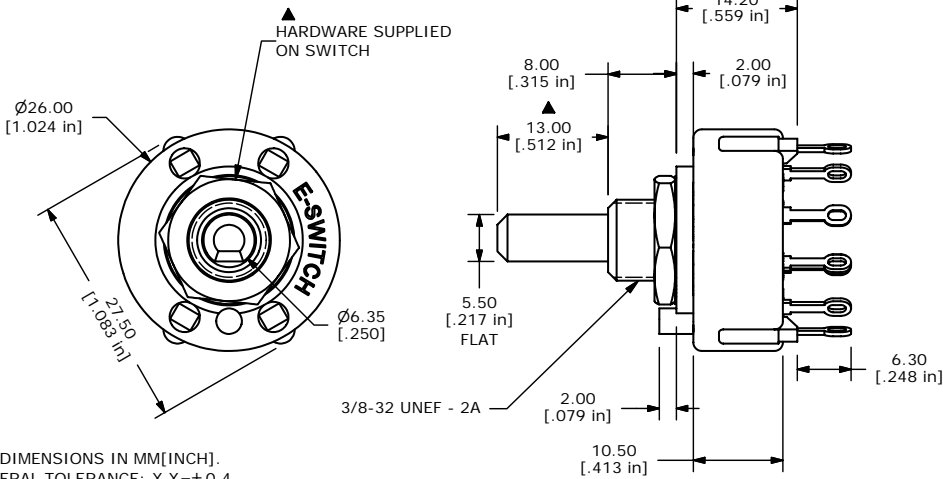
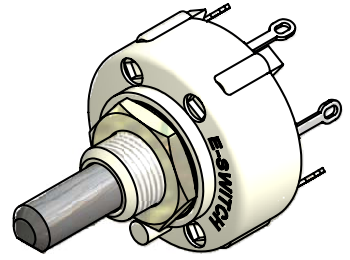
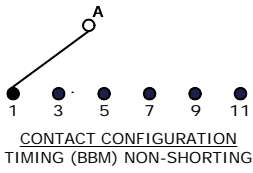

- NOTE:
1. ALL DIMENSIONS IN MM[INCH].
  2. GENERAL TOLERANCE: X.X=±0.4  
X.XX=±0.25
  3. TERM. NOS. FOR REFERENCE ONLY.
  4. CONTACT MATERIAL: SILVER
  5. CONTACT RATING: 0.3A @ 125 VAC
  6. OPERATING FORCE 800±300gm-cm
  7. OPERATING TEMP: -30°C TO 85°C
  - ▲ 8. CIRCUIT SP: 6 POSITION, 60° INDEX.
  9. DIELECTRIC STRENGTH: 500VAC - 1 MIN.
  - ▲ 10. HARDWARE SUPPLIED ON SWITCH:  
LOCKWASHER, HEXNUT, STOP RING
  11. ▲ DENOTES CRITICAL PARAMETER.
  12. 2002/95/EC (ROHS) COMPLIANT

**E-SWITCH®**

TITLE KC60A13.001NLS

A	16358	RELEASED FOR PRODUCTION	8/23/06	BO
REV	PCR NO	DESCRIPTION	DATE	BY

SCALE	1.5:1	DATE	8/23/2006	DR	BO	DWG	G510983	REV	A
-------	-------	------	-----------	----	----	-----	---------	-----	---

THE INFORMATION CONTAINED IN THIS DOCUMENT IS PROPRIETARY TO E-SWITCH AND IS NOT TO BE COPIED OR TRANSFERRED