

Excellent Integrated System Limited

Stocking Distributor

Click to view price, real time Inventory, Delivery & Lifecycle Information:

[E-Switch](#)
[LAKOAU110GRN](#)

For any questions, you can email us directly:

sales@integrated-circuit.com

SHEET 1 OF 1

Parts List				
ITEM	QTY	PART NUMBER	DESCRIPTION	
1	1	F060622	LAKOAU110	
2	1	F051601	P16 PLASTIC TERM. PROTECTOR	
3	1	F060250	29MM LA U1 NUT	
4	1	F051701	29MM RING FOR LA SERIES	
5	1	F060212	29MM GRN LENS	

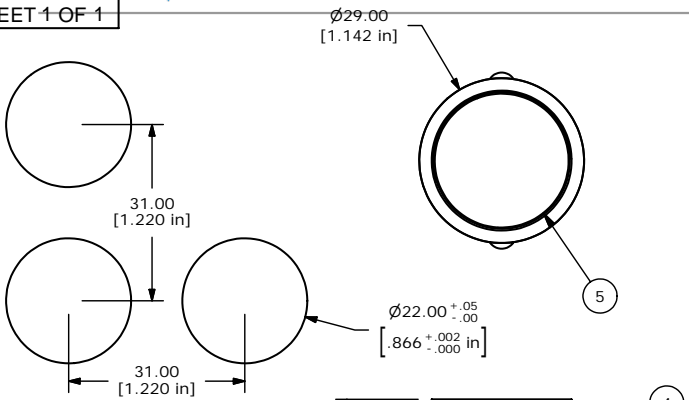

RECOMMEND PANEL MOUNTING

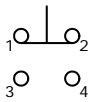

SPST
CONTACT CONFIGURATION

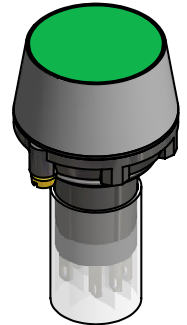
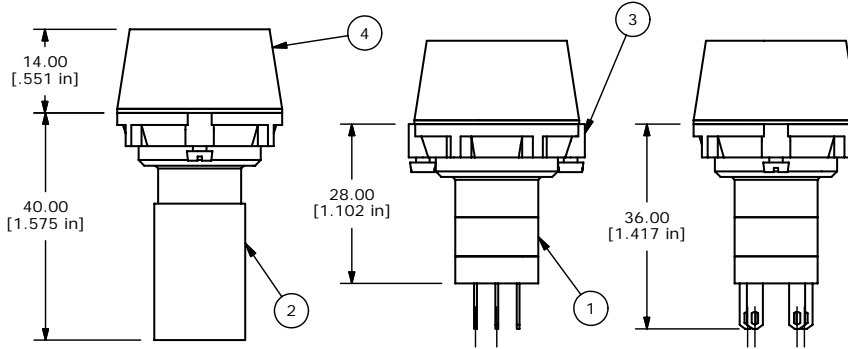

ISOMETRIC

NOTES:

1. ALL DIMENSIONS IN MM [INCH].
2. GENERAL TOLERANCE: 0.0±0.4
0.00±0.25
3. TERM. NOS. FOR REF. ONLY.
4. RATING: 5A @250VAC
8A @125VAC
.2A @250VDC
6A @24VDC
5. ELECTRIC LIFE: 25,000 MAKE-OR-BREAK CYCLES AT FULL LOAD.
6. INSULATION: 1,000 MΩ MIN.
7. DIELECTRIC STRENGTH: 2000V
8. OPERATING TEMP: -25°C TO 70°C
9. LENS COLOR: GREEN

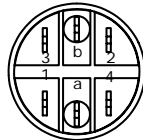

B	16054	UPDATE DIMENSIONS	5/19/06	CT
A	15380	RELEASED FOR PRODUCTION	10/11/05	PH
REV	PCR NO	DESCRIPTION	DATE	BY

TITLE LAKOAU110GRN				
SCALE 1:1	DATE 10/11/2005	DR PH	DWG XF0338P	REV B

THE INFORMATION CONTAINED IN THIS DOCUMENT IS PROPRIETARY TO E-SWITCH AND IS NOT TO BE COPIED OR TRANSFERRED