

Excellent Integrated System Limited

Stocking Distributor

Click to view price, real time Inventory, Delivery & Lifecycle Information:

[E-Switch](#)
[R1966FBLKBLKAR](#)

For any questions, you can email us directly:

sales@integrated-circuit.com

SHEET 1 OF 1

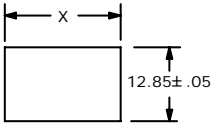

RECOMMENDED PANEL MOUNTING

PANEL THICKNESS	X
0.75-1.25	19.20-19.30
1.25-2.00	19.30-19.40
2.00-3.00	19.50-19.60

SWITCH FUNCTION		
POS. 1	POS. 2	POS. 3
(ON)	NONE	OFF
(1a-1)	N/A	OPEN

MOMENTARY=(ON)

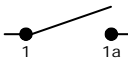

CIRCUIT: SPST

NOTES:

- ALL DIMENSIONS IN MM [INCH]
- GENERAL TOLERANCE: X.X=±0.4
X.XX=±0.25
- TERM. NOS. FOR REF. ONLY
- RATING: 15A @125VAC;
8A @250VAC.
- LAMP VOLTAGE: NO LAMP
- MATERIAL:
CONTACT SURFACE: SILVER ALLOY
TERMINAL: COPPER ALLOY w/SILVER PLATE
- ELECTRICAL LIFE: 10,000 CYCLES
- CONTACT RESISTANCE: <20 MILLI-OHMS INITIAL
- DIELECTRIC STRENGTH: >1,500V AC 1 MIN
- ▲DENOTES CRITICAL PARAMETER.
- 2002/95/EC (ROHS) COMPLIANT.

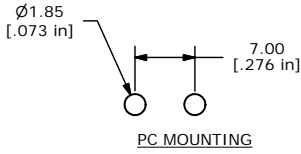

PC MOUNTING

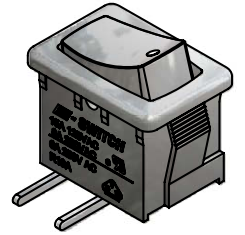
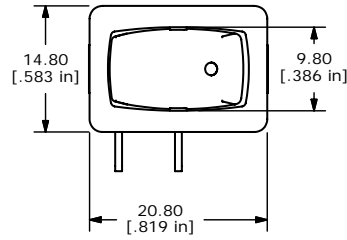

ISOMETRIC

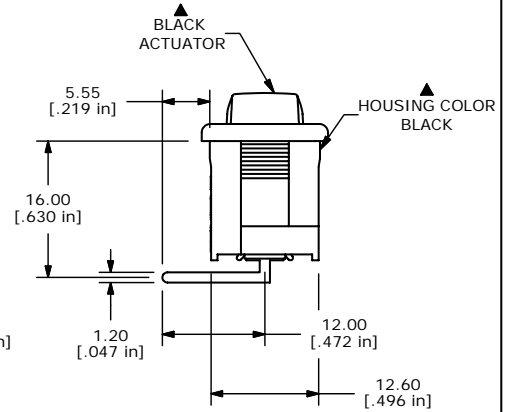
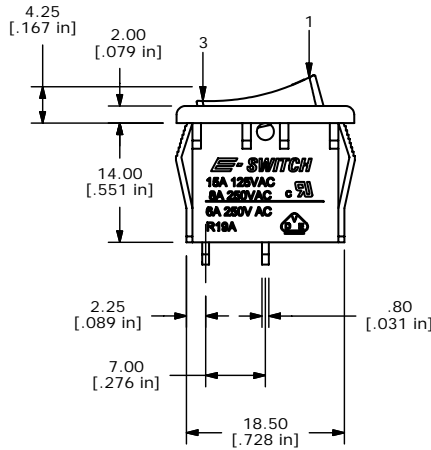

B	16741	UPDATED DRAWING	12/7/2006	TN	TITLE R1966FBLKBLKAR
A	15540	RELEASED FOR PRODUCTION	11/17/05	PH	
REV	PCR NO	DESCRIPTION	DATE	BY	
<small>THE INFORMATION CONTAINED IN THIS DOCUMENT IS PROPRIETARY TO E-SWITCH AND IS NOT TO BE COPIED OR TRANSFERRED</small>					
SCALE	1.5:1	DATE	12/7/2006	DR	TN
DWG	M302427	REV	B		