

Excellent Integrated System Limited

Stocking Distributor

Click to view price, real time Inventory, Delivery & Lifecycle Information:

[E-Switch](#)
[TL1105PF100Q](#)

For any questions, you can email us directly:

sales@integrated-circuit.com

SHEET OF

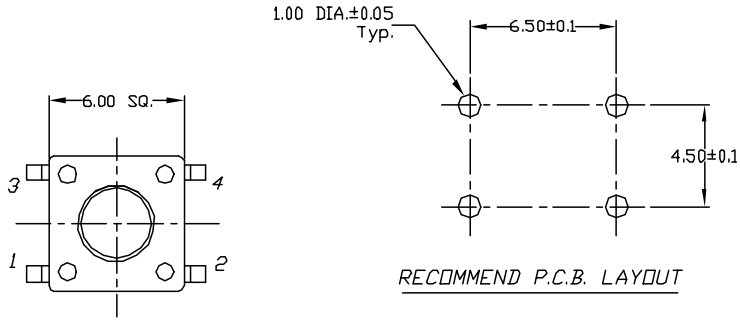

NOTES:

1. ALL DIMENSIONS IN MM
2. GENERAL TOLERANCE: 0.0=±0.4
0.00=±0.25
3. TERM. NOS. FOR REF. ONLY
4. RATING: 50mA, @12V DC
5. TRAVEL: 0.25±0.1mm
6. CONTACT RESISTANCE: 100m ohms max.
7. ELECTRICAL LIFE: 100,000 CYCLES MIN.
8. INSULATION RESISTANCE: 100M ohms min.
9. DIELECTRIC STRENGTH: 250V RMS MIN.
10. OPERATING TEMP.: -30°C to +85°C

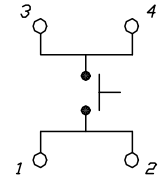
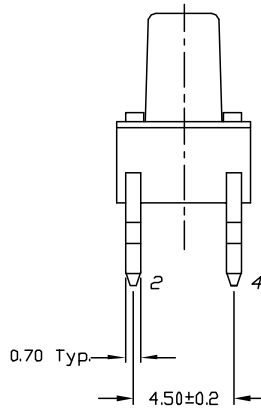
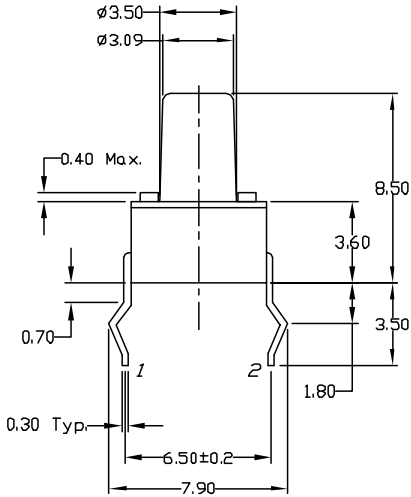

CIRCUIT: SPST

CONTACT CONFIGURATION

E-SWITCH®

					TITLE				
					TL 1105P F100 Q				
A	10028	RELEASED FOR PRODUCTION			SCALE	DATE	DR	DWG	REV
REV.	ECN No.	DESCRIPTION	DATE	CHKD	4:1	11/25/98	MM	P010028	A
THE INFORMATION CONTAINED IN THIS DOCUMENT IS PROPRIETARY TO E-SWITCH AND IS NOT TO BE COPIED OR TRANSFERRED									