

Excellent Integrated System Limited

Stocking Distributor

Click to view price, real time Inventory, Delivery & Lifecycle Information:

[STMicroelectronics](#)
[ST2349QTR](#)

For any questions, you can email us directly:

sales@integrated-circuit.com



ST2349

4-bit dual supply level translator without direction control pin

Features

- 90 Mbps (max) data rate when driven by a totem pole driver
- 8 Mbps (max) data rate when driven by an open drain pole driver
- Bi-directional level translation without direction control pin
- Wide V_L voltage range of 1.65 to 3.6 V
- Wide V_{CC} voltage range of 1.80 to 5.5 V
- Power down mode feature – when either supply is off, all I/Os are in high impedance
- Low quiescent current (max 24 μ A)
- Able to be driven by totem pole and open drain drivers
- 5.5 V tolerant enable pin
- ESD performance on all pins: ± 2 kV HBM
- Small package and footprint
QFN16 (2.6 x 1.8 mm) package

Applications

- Low voltage system level translation
- Mobile phones and other mobile devices
- I²C level translation
- UART level translation

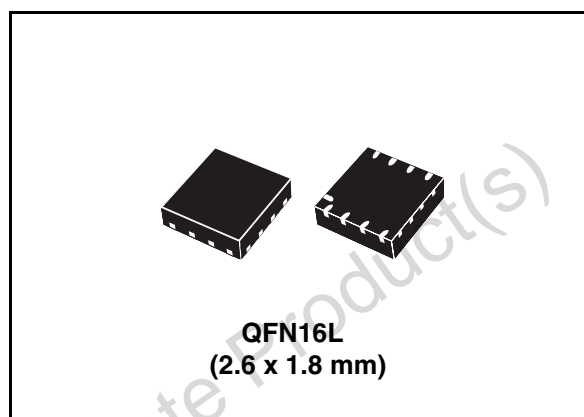

Description

The ST2349 is a 4-bit dual supply level translator which provides the level shifting capability to allow data transfer in a multi-voltage system. Externally applied voltages, V_{CC} and V_L , set the logic levels on either side of the device. It utilizes transmission gate-based design that allows bi-directional level translation without a control pin.

The ST2349 accepts a V_L from 1.65 to 3.6 V and V_{CC} from 1.80 to 5.5 V, making it ideal for data transfer between low-voltage ASICs/PLD and higher voltage systems. This device has a tri-state output mode which can be used to disable all I/Os.

The ST2349 supports power down mode when V_{CC} is grounded/floating and the device is disabled via the OE pin.

Table 1. Device summary

Order code	Package	Packaging
ST2349QTR	QFN16 (2.6 x 1.8 mm)	Tape and reel (3000 parts per reel)

Contents

1	Pin settings	5
1.1	Pin connection	5
1.2	Pin description	5
2	Device block diagrams	6
3	Supplementary notes	7
3.1	Driver requirement	7
3.2	Load driving capability	7
3.3	Power off feature	7
3.4	Truth table	7
4	Maximum rating	8
4.1	Recommended operating conditions	8
5	Electrical characteristics	9
5.1	AC characteristics (device driven by open drain driver)	11
5.2	AC characteristics (device driven by totem pole driver)	13
6	Waveforms	16
7	Package mechanical data	18
8	Revision history	22

List of figures

Figure 1.	ST2349 pin connection (top through view)	5
Figure 2.	ST2349 block diagram	6
Figure 3.	Application block diagram.	6
Figure 4.	Test circuit	15
Figure 5.	Waveform - propagation delay (f = 1 MHz; 50% duty cycle).	16
Figure 6.	Waveform - output enable and disable time (f = 1 MHz; 50% duty cycle)	17
Figure 7.	QFN16L (2.6 x 1.8 mm) package outline	18
Figure 8.	QFN16L (2.6 x 1.8 mm) footprint recommendation	19
Figure 9.	QFN16L (2.6 x 1.8 mm) carrier tape	20
Figure 10.	QFN16L (2.6 x 1.8 mm) reel information	21

Obsolete Product(s) - Obsolete Product(s)

List of tables

Table 1.	Device summary	1
Table 2.	ST2349 pin description	5
Table 3.	Truth table.	7
Table 4.	Absolute maximum ratings	8
Table 5.	Recommended operating conditions	8
Table 6.	DC characteristics (over recommended operating conditions unless otherwise noted. All typical values are at $T_A = 25\text{ }^\circ\text{C}$)	
Table 7.	AC characteristics - test conditions: $V_L = 1.65 - 1.8\text{ V}$ (load $C_L = 15\text{ pF}$; $R_{up} = 4.7\text{ k}\Omega$; driver $t_r = t_f \leq 2\text{ ns}$) over temperature range $-40\text{ }^\circ\text{C}$ to $85\text{ }^\circ\text{C}$ 11	
Table 8.	AC characteristics - test conditions: $V_L = 2.5 - 2.7\text{ V}$ (load $C_L = 15\text{ pF}$; $R_{up} = 4.7\text{ k}\Omega$; driver $t_r = t_f \leq 2\text{ ns}$) over temperature range $-40\text{ }^\circ\text{C}$ to $85\text{ }^\circ\text{C}$ 11	
Table 9.	AC characteristics - test conditions: $V_L = 2.7 - 3.6\text{ V}$ (load $C_L = 15\text{ pF}$; $R_{up} = 4.7\text{ k}\Omega$; driver $t_r = t_f \leq 2\text{ ns}$) over temperature range $-40\text{ }^\circ\text{C}$ to $85\text{ }^\circ\text{C}$ 12	
Table 10.	AC characteristics (test conditions: $V_L = 1.65 - 1.8\text{ V}$ (load $C_L = 15\text{ pF}$; $R_{up} = 10\text{ k}\Omega$; driver $t_r = t_f \leq 2\text{ ns}$) over temperature range $-40\text{ }^\circ\text{C}$ to $85\text{ }^\circ\text{C}$)13	
Table 11.	AC characteristics (test conditions: $V_L = 2.5 - 2.7\text{ V}$ (load $C_L = 15\text{ pF}$; $R_{up} = 10\text{ k}\Omega$; driver $t_r = t_f \leq 2\text{ ns}$) over temperature range $-40\text{ }^\circ\text{C}$ to $85\text{ }^\circ\text{C}$)13	
Table 12.	AC characteristics (test conditions: $V_L = 2.7 - 3.6\text{ V}$ (load $C_L = 15\text{ pF}$; $R_{up} = 10\text{ k}\Omega$; driver $t_r = t_f \leq 2\text{ ns}$) over temperature range $-40\text{ }^\circ\text{C}$ to $85\text{ }^\circ\text{C}$)14	
Table 13.	Test circuit switches	15
Table 14.	Waveform symbol value	16
Table 15.	QFN16L (2.6 x 1.8 mm) mechanical data.	19
Table 16.	Document revision history	22

1 Pin settings

1.1 Pin connection

Figure 1. ST2349 pin connection (top through view)

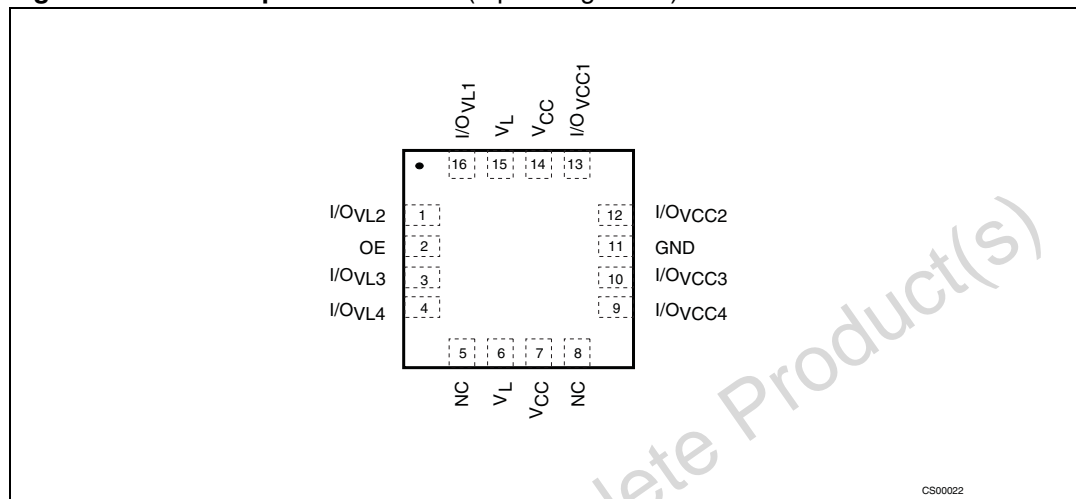

1.2 Pin description

Table 2. ST2349 pin description

Pin number	Symbol	Name and function
1	I/OVL2	Data input/output
2	OE	Output enable
3	I/OVL3	Data input/output
4	I/OVL4	Data input/output
5	NC	No connection
6	VL	Supply voltage
7	VCC	Supply voltage
8	NC	No connection
9	I/OVCC4	Data input/output
10	I/OVCC3	Data input/output
11	GND	Ground
12	I/OVCC2	Data input/output
13	I/OVCC1	Data input/output
14	VCC	Supply voltage
15	VL	Supply voltage
16	I/OVL1	Data input/output

2 Device block diagrams

Figure 2. ST2349 block diagram

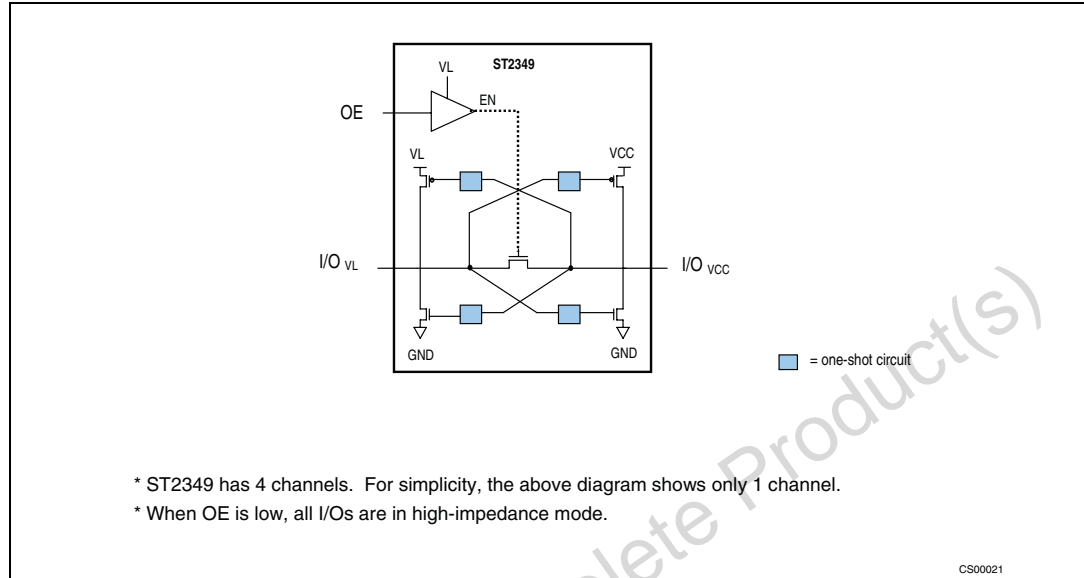
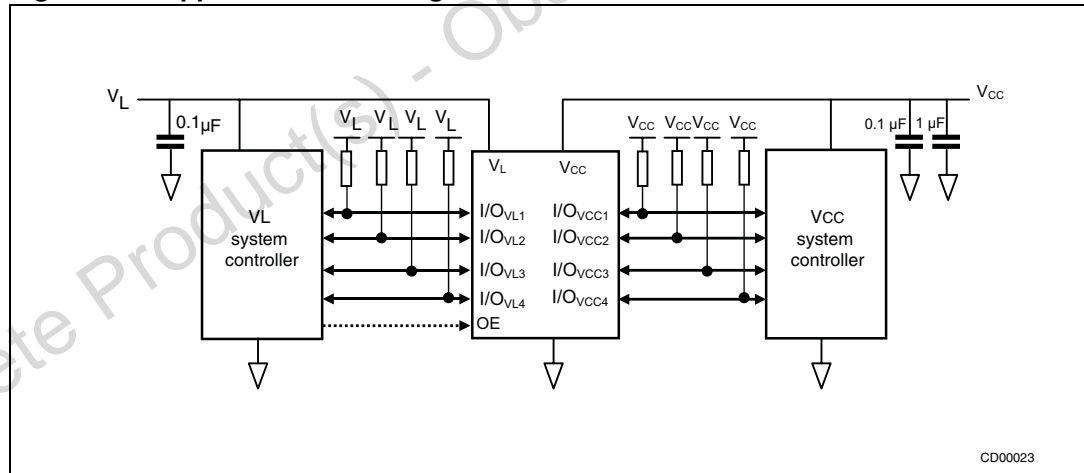

Figure 3. Application block diagram



3 Supplementary notes

3.1 Driver requirement

The ST2349 may be driven by an open drain or totem pole driver and the nature of the device's output is "open drain". It must not be used to drive a pull-down resistor since the impedance of the output at HIGH state depends on the pull-up resistor placed at the I/Os.

As the device has pull-up resistors on both the I/O_{VCC} and I/O_{VL} ports, the user needs to ensure that the driver is able to sink the required amount of current. For example, if the settings are V_{CC} = 5.5 V, V_L = 4.3 V and the pull-up resistor is 10 kΩ, then the driver must be able to sink at least (5.5 V/10 kΩ) + (4.3 V/10 kΩ) = 1 mA and still meet the V_{IL} requirements of the ST2349.

3.2 Load driving capability

To support the open drain system, the one-shot transistor is turned on only during state transition at the output side. When it drives a high state, after the one-shot transistor is turned off, only the pull-up resistor is able to maintain the state. In this case, the resistive load is not recommended.

During the translation from V_{CC} side to V_L side, the oscillation might be triggered when the signal is reflected back as a glitch. This is caused by the architecture of the device (auto-direction).

When using the ST2349, care need to be taken in the PCB data-track design and output loading. It is recommended that the load is less than 25 pf.

3.3 Power off feature

In some applications where it might be required to turn off one of the power supplies powering up the level translator, the user may turn off the V_{CC} only when the OE pin is low (device is disabled). There will be no current consumption in V_L due to floating gates or other causes, and the I/Os are in a high-impedance state in this mode.

3.4 Truth table

Table 3. Truth table

Enable	Bi-directional Input/Output	
OE	I/O _{VCC}	I/O _{VL}
H ⁽¹⁾	H ⁽²⁾	H ⁽¹⁾
H ⁽¹⁾	L	L
L	Z ⁽³⁾	Z ⁽³⁾

1. High level V_L power supply referred
2. High level V_{CC} power supply referred
3. Z = high impedance

4 Maximum rating

Stressing the device above the rating listed in the “Absolute maximum ratings” table may cause permanent damage to the device. These are stress ratings only, and operation of the device at these or any other conditions above those indicated in the operating sections of this specification is not implied. Exposure to absolute maximum rating conditions for extended periods may affect device reliability. Refer also to the STMicroelectronics SURE Program and other relevant quality documents.

Table 4. Absolute maximum ratings

Symbol	Parameter	Value	Unit
V_L	Supply voltage	-0.3 to 4.6	V
V_{CC}	Supply voltage	-0.3 to 6.5	V
V_{OE}	DC control input voltage	-0.3 to 6.5	V
$V_{I/OVL}$	DC I/O _{VL} input voltage (OE = GND or V_L)	-0.3 to $V_L + 0.3$	V
$V_{I/OVCC}$	DC I/O _{VCC} input voltage (OE = GND or V_L)	-0.3 to $V_{CC} + 0.3$	V
I_{IK}	DC input diode current	-20	mA
$I_{I/OVL}$	DC output current	±25	mA
$I_{I/OVCC}$	DC output current	±258	mA
I_{SCTOUT}	Short circuit duration, continuous	40	mA
P_D	Power dissipation ⁽¹⁾	500	mW
T_{STG}	Storage temperature	-65 to 150	°C
TL	Lead temperature (10 seconds)	300	°C
ESD	Electrostatic discharge protection (HBM)	±2	kV

1. 500mW: 65 °C derated to 300 mW by 10W/°C: 65 °C to 85 °C

4.1 Recommended operating conditions

Table 5. Recommended operating conditions

Symbol	Parameter	Min	Typ	Max	Unit
V_L	Supply voltage	1.65		3.6	V
$V_{CC}^{(1)}$	Supply voltage	1.8		5.5	V
V_{OE}	Input voltage (OE output enable pin, V_L power supply referred)	0		3.6	V
$V_{I/OVL}$	I/O _{VL} voltage	0		V_L	V
$V_{I/OVCC}$	I/O _{VCC} voltage	0		V_{CC}	V
T_{op}	Operating temperature	-40		85	°C
dt/dV	Input rise and fall time (for 45 Mbps operation)	0		1	ns/V

1. V_{CC} must be greater than V_L .

5 Electrical characteristics

Table 6. DC characteristics (over recommended operating conditions unless otherwise noted. All typical values are at $T_A = 25\text{ }^\circ\text{C}$)

Symbol	Parameter	Test conditions			Value					Unit
		V_L	V_{CC}		$T_A = 25\text{ }^\circ\text{C}$			-40 to 85 $^\circ\text{C}$		
					Min	Typ	Max	Min	Max	
V_{IHL}	High level input voltage (I/O_{VL})	1.65	V_L to 5.5		1.4			1.4		V
		2.0			1.6			1.6		
		2.5			2.0			2.0		
		3.0			2.4			2.4		
		3.6			2.8			2.8		
V_{ILL}	Low level input voltage (I/O_{VL})	1.65	V_L to 5.5				0.3		0.3	V
		2.0					0.4		0.4	
		2.5					0.5		0.5	
		3.0					0.6		0.6	
		3.6					0.8		0.8	
V_{IHC}	High level input voltage (I/O_{VCC})	1.65 to V_{CC}	1.8		1.6			1.6		V
			2.5		2.3			2.3		
			3.0		2.7			2.7		
			3.6		3.3			3.3		
			4.3		3.5			3.5		
			5.5		4.2			4.2		
V_{ILC}	Low level input voltage (I/O_{VCC})	1.65 - 2.5	3 - 5.5					0.3		V
		2.7 - 3.6	3.6 - 5.5					0.5		
V_{IH-OE}	High level input voltage (OE)	V_L to 5.5	1.65		1.0			1.0		V
			2.0		1.2			1.2		
			2.5		1.4			1.4		
			3.0		1.6			1.6		
			3.6		2.0			2.0		
V_{IL-OE}	Low level input voltage (OE)	V_L to 5.5	1.65				0.33		0.33	V
			2.0				0.40		0.40	
			2.5				0.50		0.50	
			3.0				0.60		0.60	
			3.6				0.75		0.75	

Electrical characteristics

ST2349

Table 6. DC characteristics (over recommended operating conditions unless otherwise noted. All typical values are at $T_A = 25\text{ }^\circ\text{C}$) (continued)

Symbol	Parameter	Test conditions			Value					Unit
		V_L	V_{CC}		$T_A = 25\text{ }^\circ\text{C}$			$-40\text{ to }85\text{ }^\circ\text{C}$		
					Min	Typ	Max	Min	Max	
V_{OLL}	Low level output voltage (I/O_{VL})	1.65 to 3.6	V_L to 5.5	$I_O = 1.0\text{ mA}$ $I/O_{VCC} \leq 0.15\text{ V}$			0.40		0.40	V
V_{OLC}	Low level output voltage (I/O_{VCC})	1.65 to 3.6	V_L to 5.5	$I_O = 1.0\text{ mA}$ $I/O_{VL} \leq 0.15\text{ V}$			0.40		0.40	V
I_{OE}	Control input leakage current (OE)	1.65 to 3.6	V_L to 5.5	$V_{OE} = \text{GND}$ or V_L			± 0.1		± 0.1	μA
I_{IO_LKG}	High impedance leakage current (I/O_{VL} , I/O_{VCC})	1.65 to 3.6	V_L to 5.5	OE = GND			± 0.1		± 0.1	μA
I_{QVCC}	Quiescent supply current V_{CC}	1.65 to 3.6	V_L to 5.5	only pull-up resistor connected to I/O		6	10		24	μA
I_{QVL}	Quiescent supply current V_L	1.65 to 3.6	V_L to 5.5	only pull-up resistor connected to I/O		0.01	0.1		1	μA
I_{Z-VCC}	High impedance quiescent supply current V_{CC}	1.65 to 3.6	V_L to 5.5	OE = GND; only pull-up resistor connected to I/O		6	10		24	μA
I_{Z-VL}	High impedance quiescent supply current V_L	1.65 to 3.6	V_L to 5.5	OE = GND; only pull-up resistor connected to I/O		0.01	0.1		1	μA

ST2349

Electrical characteristics

5.1 AC characteristics (device driven by open drain driver)

Table 7. AC characteristics - test conditions: $V_L = 1.65 - 1.8 \text{ V}$ (load $C_L = 15 \text{ pF}$; $R_{up} = 4.7 \text{ k}\Omega$; driver $t_r = t_f \leq 2 \text{ ns}$) over temperature range $-40 \text{ }^\circ\text{C}$ to $85 \text{ }^\circ\text{C}$

Symbol	Parameter	$V_{CC} = 1.8 - 2.5 \text{ V}$		$V_{CC} = 2.7 - 3.6 \text{ V}$		$V_{CC} = 4.3 - 5.5 \text{ V}$		Unit
		Min	Max	Min	Max	Min	Max	
t_{RVCC}	Rise time I/O_{VCC}		80		50		30	ns
t_{FVCC}	Fall time I/O_{VCC}		3		3		3	ns
t_{RVL}	Rise time I/O_{VL}		7		6		6	ns
t_{FVL}	Fall time I/O_{VL}		4		5		5	ns
$t_{I/OVL-VCC}$	Propagation delay time I/O_{VL-LH} to I/O_{VCC-LH} I/O_{VL-HL} to I/O_{VCC-HL}	t_{PLH}	5		5		5	ns
		t_{PHL}	5		5		5	ns
$t_{I/OVCC-VL}$	Propagation delay time I/O_{VCC-LH} to I/O_{VL-LH} I/O_{VCC-HL} to I/O_{VL-LH}	t_{PLH}	5		5		5	ns
		t_{PHL}	5		7		7	ns
t_{PZL} t_{PZH} t_{PLZ} t_{PHZ}	Output enable and disable time	En	10		10		10	ns
		Dis	40		40		40	ns
D_R	Data rate ⁽¹⁾		1.6		2.5		4	MHz

1. The data rate is guaranteed based on the condition that the output I/O signal rise/fall time is less than 15% of the input I/O signal period; the input I/O signal is at 50% duty cycle and the output I/O signal duty cycle deviation not less than 30%.

Table 8. AC characteristics - test conditions: $V_L = 2.5 - 2.7 \text{ V}$ (load $C_L = 15 \text{ pF}$; $R_{up} = 4.7 \text{ k}\Omega$; driver $t_r = t_f \leq 2 \text{ ns}$) over temperature range $-40 \text{ }^\circ\text{C}$ to $85 \text{ }^\circ\text{C}$

Symbol	Parameter	$V_{CC} = 2.7 - 3.6 \text{ V}$		$V_{CC} = 4.3 - 5.5 \text{ V}$		Unit
		Min	Max	Min	Max	
t_{RVCC}	Rise time I/O_{VCC}		70		40	ns
t_{FVCC}	Fall time I/O_{VCC}		3		3	ns
t_{RVL}	Rise time I/O_{VL}		5		5	ns
t_{FVL}	Fall time I/O_{VL}		3		3	ns
$t_{I/OVL-VCC}$	Propagation delay time I/O_{VL-LH} to I/O_{VCC-LH} I/O_{VL-HL} to I/O_{VCC-HL}	t_{PLH}	2		2	ns
		t_{PHL}	3		3	ns
$t_{I/OVCC-VL}$	Propagation delay time I/O_{VCC-LH} to I/O_{VL-LH} I/O_{VCC-HL} to I/O_{VL-LH}	t_{PLH}	3		3	ns
		t_{PHL}	4		4	ns

Electrical characteristics

ST2349

Table 8. AC characteristics - test conditions: $V_L = 2.5 - 2.7$ V (load $C_L = 15$ pF; $R_{up} = 4.7$ k Ω ; driver $t_r = t_f \leq 2$ ns) over temperature range -40 °C to 85 °C

Symbol	Parameter	$V_{CC} = 2.7 - 3.6$ V		$V_{CC} = 4.3 - 5.5$ V		Unit
		Min	Max	Min	Max	
t_{PZL} t_{PZH} t_{PLZ} t_{PHZ}	Output enable and disable time	En	6		6	ns
		Dis	40		40	ns
D_R	Data rate ⁽¹⁾		2.5		3.2	MHz

1. The data rate is guaranteed based on the condition that the output I/O signal rise/fall time is less than 15% of the input I/O signal period; the input I/O signal is at 50% duty cycle and the output I/O signal duty cycle deviation not less than 30%.

Table 9. AC characteristics - test conditions: $V_L = 2.7 - 3.6$ V (load $C_L = 15$ pF; $R_{up} = 4.7$ k Ω ; driver $t_r = t_f \leq 2$ ns) over temperature range -40 °C to 85 °C

Symbol	Parameter	$V_{CC} = 4.3 - 5.5$ V		Unit
		Min	Max	
t_{RVCC}	Rise time I/O_{VCC}		55	ns
t_{FVCC}	Fall time I/O_{VCC}		3	ns
t_{RVL}	Rise time I/O_{VL}		4	ns
t_{FVL}	Fall time I/O_{VL}		3	ns
$t_{I/OVL-VCC}$	Propagation delay time I/O_{VL-LH} to I/O_{VCC-LH} I/O_{VL-HL} to I/O_{VCC-HL}	t_{PLH}	2	ns
		t_{PHL}	4	ns
$t_{I/OVCC-VL}$	Propagation delay time I/O_{VCC-LH} to I/O_{VL-LH} I/O_{VCC-HL} to I/O_{VL-HL}	t_{PLH}	4	ns
		t_{PHL}	4	ns
t_{PZL} t_{PZH} t_{PLZ} t_{PHZ}	Output enable and disable time	En	6	ns
		Dis	40	ns
D_R	Data rate ⁽¹⁾		2.8	MHz

1. The data rate is guaranteed based on the condition that the output I/O signal rise/fall time is less than 15% of the input I/O signal period; the input I/O signal is at 50% duty cycle and the output I/O signal duty cycle deviation not less than 30%.

ST2349

Electrical characteristics

5.2 AC characteristics (device driven by totem pole driver)

Table 10. AC characteristics (test conditions: $V_L = 1.65 - 1.8$ V (load $C_L = 15$ pF; $R_{up} = 10$ k Ω ; driver $t_r = t_f \leq 2$ ns) over temperature range -40 °C to 85 °C)

Symbol	Parameter	$V_{CC} = 1.8 - 2.5$ V		$V_{CC} = 2.7 - 3.6$ V		$V_{CC} = 4.3 - 5.5$ V		Unit
		Min	Max	Min	Max	Min	Max	
t_{RVCC}	Rise time I/O_{VCC}		7		3		4	ns
t_{FVCC}	Fall time I/O_{VCC}		7		3		3	ns
t_{RVL}	Rise time I/O_{VL}		6		4		5	ns
t_{FVL}	Fall time I/O_{VL}		4		4		4	ns
$t_{I/OVL-VCC}$	Propagation delay time I/O_{VL-LH} to I/O_{VCC-LH} I/O_{VL-HL} to I/O_{VCC-HL}	t_{PLH}	6		5		4	ns
		t_{PHL}	5		5		5	ns
$t_{I/OVCC-VL}$	Propagation delay time I/O_{VCC-LH} to I/O_{VL-LH} I/O_{VCC-HL} to I/O_{VL-HL}	t_{PLH}	6		5		4	ns
		t_{PHL}	4.5		5.2		7	ns
t_{PZL} t_{PZH} t_{PLZ} t_{PHZ}	Output enable and disable time	En	10		10		10	ns
		Dis	40		40		40	ns
D_R	Data rate ⁽¹⁾		12		32		32	MHz

1. The data rate is guaranteed based on the condition that the output I/O signal rise/fall time is less than 15% of the input I/O signal period; the input I/O signal is at 50% duty cycle and the output I/O signal duty cycle deviation not less than 30%.

Table 11. AC characteristics (test conditions: $V_L = 2.5 - 2.7$ V (load $C_L = 15$ pF; $R_{up} = 10$ k Ω ; driver $t_r = t_f \leq 2$ ns) over temperature range -40 °C to 85 °C)

Symbol	Parameter	$V_{CC} = 2.7 - 3.6$ V		$V_{CC} = 4.3 - 5.5$ V		Unit
		Min	Max	Min	Max	
t_{RVCC}	Rise time I/O_{VCC}		6		4	ns
t_{FVCC}	Fall time I/O_{VCC}		3		3	ns
t_{RVL}	Rise time I/O_{VL}		5		5	ns
t_{FVL}	Fall time I/O_{VL}		3		3	ns
$t_{I/OVL-VCC}$	Propagation delay time I/O_{VL-LH} to I/O_{VCC-LH} I/O_{VL-HL} to I/O_{VCC-HL}	t_{PLH}	3.5		3	ns
		t_{PHL}	4		4	ns
$t_{I/OVCC-VL}$	Propagation delay time I/O_{VCC-LH} to I/O_{VL-LH} I/O_{VCC-HL} to I/O_{VL-HL}	t_{PLH}	2.5		2.1	ns
						ns
		t_{PHL}	4		4	ns
						ns

Electrical characteristics

ST2349

Table 11. AC characteristics (test conditions: $V_L = 2.5 - 2.7$ V (load $C_L = 15$ pF; $R_{up} = 10$ k Ω ; driver $t_r = t_f \leq 2$ ns) over temperature range -40 °C to 85 °C) (continued)

Symbol	Parameter	$V_{CC} = 2.7 - 3.6$ V		$V_{CC} = 4.3 - 5.5$ V		Unit
		Min	Max	Min	Max	
t_{PZL} t_{PZH} t_{PLZ} t_{PHZ}	Output enable and disable time	En	6	6	6	ns
		Dis	40	40	40	ns
D_R	Data rate ⁽¹⁾		45	45	45	MHz

1. The data rate is guaranteed based on the condition that the output I/O signal rise/fall time is less than 15% of the input I/O signal period; the input I/O signal is at 50% duty cycle and the output I/O signal duty cycle deviation not less than 30%.

Table 12. AC characteristics (test conditions: $V_L = 2.7 - 3.6$ V (load $C_L = 15$ pF; $R_{up} = 10$ k Ω ; driver $t_r = t_f \leq 2$ ns) over temperature range -40 °C to 85 °C)

Symbol	Parameter	$V_{CC} = 4.3 - 5.5$ V		Unit
		Min	Max	
t_{RVCC}	Rise time I/O $_{VCC}$		5	ns
t_{FVCC}	Fall time I/O $_{VCC}$		3	ns
t_{RVL}	Rise time I/O $_{VL}$		4	ns
t_{FVL}	Fall time I/O $_{VL}$		3	ns
$t_{I/OVL-VCC}$	Propagation delay time I/O $_{VL}$ -LH to I/O $_{VCC}$ -LH I/O $_{VL}$ -HL to I/O $_{VCC}$ -HL	t_{PLH}	2.5	ns
		t_{PHL}	4	ns
$t_{I/OVCC-VL}$	Propagation delay time I/O $_{VCC}$ -LH to I/O $_{VL}$ -LH I/O $_{VCC}$ -HL to I/O $_{VL}$ -HL	t_{PLH}	2	ns
				ns
		t_{PHL}	4	ns
				ns
t_{PZL} t_{PZH} t_{PLZ} t_{PHZ}	Output enable and disable time	En	6	ns
		Dis	40	ns
D_R	Data rate ⁽¹⁾		45	MHz

1. The data rate is guaranteed based on the condition that the output I/O signal rise/fall time is less than 15% of the input I/O signal period; the input I/O signal is at 50% duty cycle and the output I/O signal duty cycle deviation not less than 30%.

ST2349

Electrical characteristics

Figure 4. Test circuit

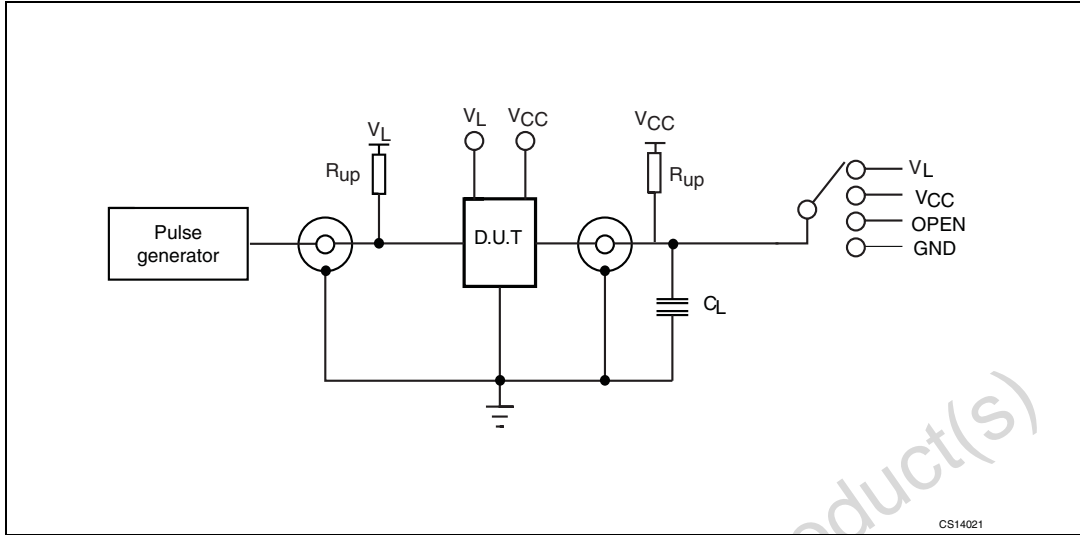

Table 13. Test circuit switches

Test	Switch		
	Driving I/O _{V_L}	Driving I/O _{V_{CC}}	Open drain driving
t_{PLH} , t_{PHL}	Open	Open	Open

6 Waveforms

Table 14. Waveform symbol value

Symbol	Driving I/O _{VL}		Driving I/O _{VCC}	
	$1.8\text{ V} \leq V_L \leq V_{CC} \leq 2.5\text{ V}$	$3.3\text{ V} \leq V_L \leq V_{CC} \leq 5.0\text{ V}$	$1.8\text{ V} \leq V_L \leq V_{CC} \leq 2.5\text{ V}$	$3.3\text{ V} \leq V_L \leq V_{CC} \leq 5.0\text{ V}$
V _{IH}	V _L	V _L	V _{CC}	V _{CC}
V _{IM}	50% V _L	50% V _L	50% V _{CC}	50% V _{CC}
V _{OM}	50% V _{CC}	50% V _{CC}	50% V _L	50% V _L
V _X	V _{OL} + 0.15V	V _{OL} + 0.3V	V _{OL} + 0.15V	V _{OL} + 0.3V
V _Y	V _{OH} - 0.15V	V _{OH} - 0.3V	V _{OH} - 0.15V	V _{OH} - 0.3V

Figure 5. Waveform - propagation delay (f = 1 MHz; 50% duty cycle)

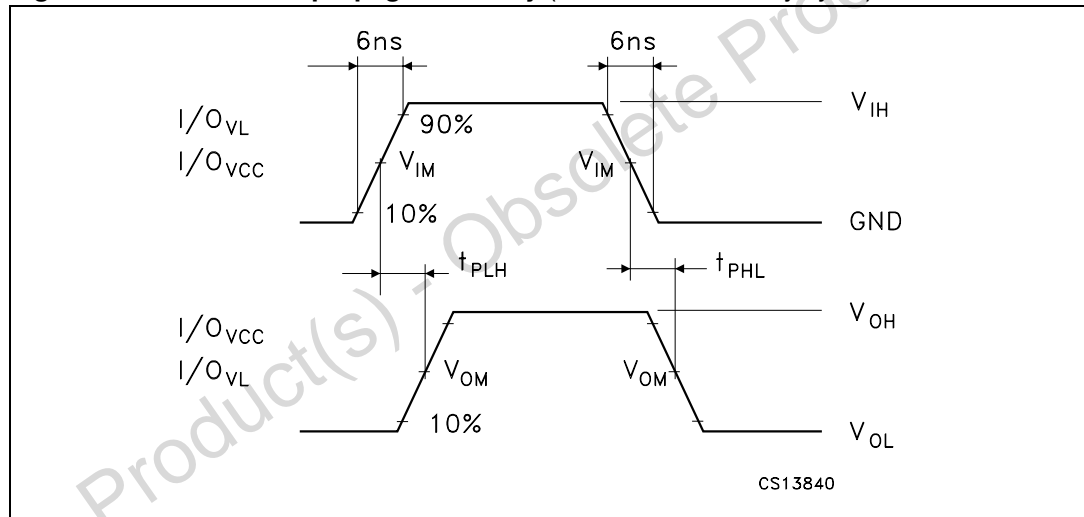
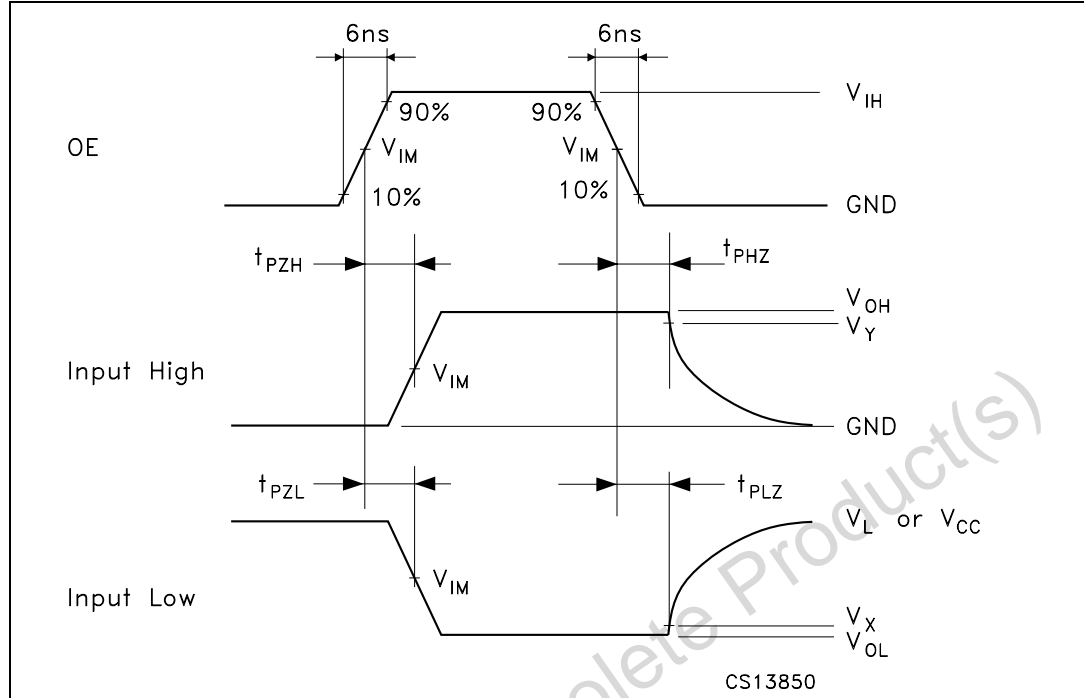

Figure 6. Waveform - output enable and disable time (f = 1 MHz; 50% duty cycle)



Obsolete Product(s) - Obsolete Product(s)

7 Package mechanical data

In order to meet environmental requirements, ST offers these devices in ECOPACK[®] packages. These packages have a Lead-free second level interconnect. The category of second level interconnect is marked on the package and on the inner box label, in compliance with JEDEC Standard JESD97. The maximum ratings related to soldering conditions are also marked on the inner box label. ECOPACK is an ST trademark. ECOPACK specifications are available at: www.st.com.

Figure 7. QFN16L (2.6 x 1.8 mm) package outline

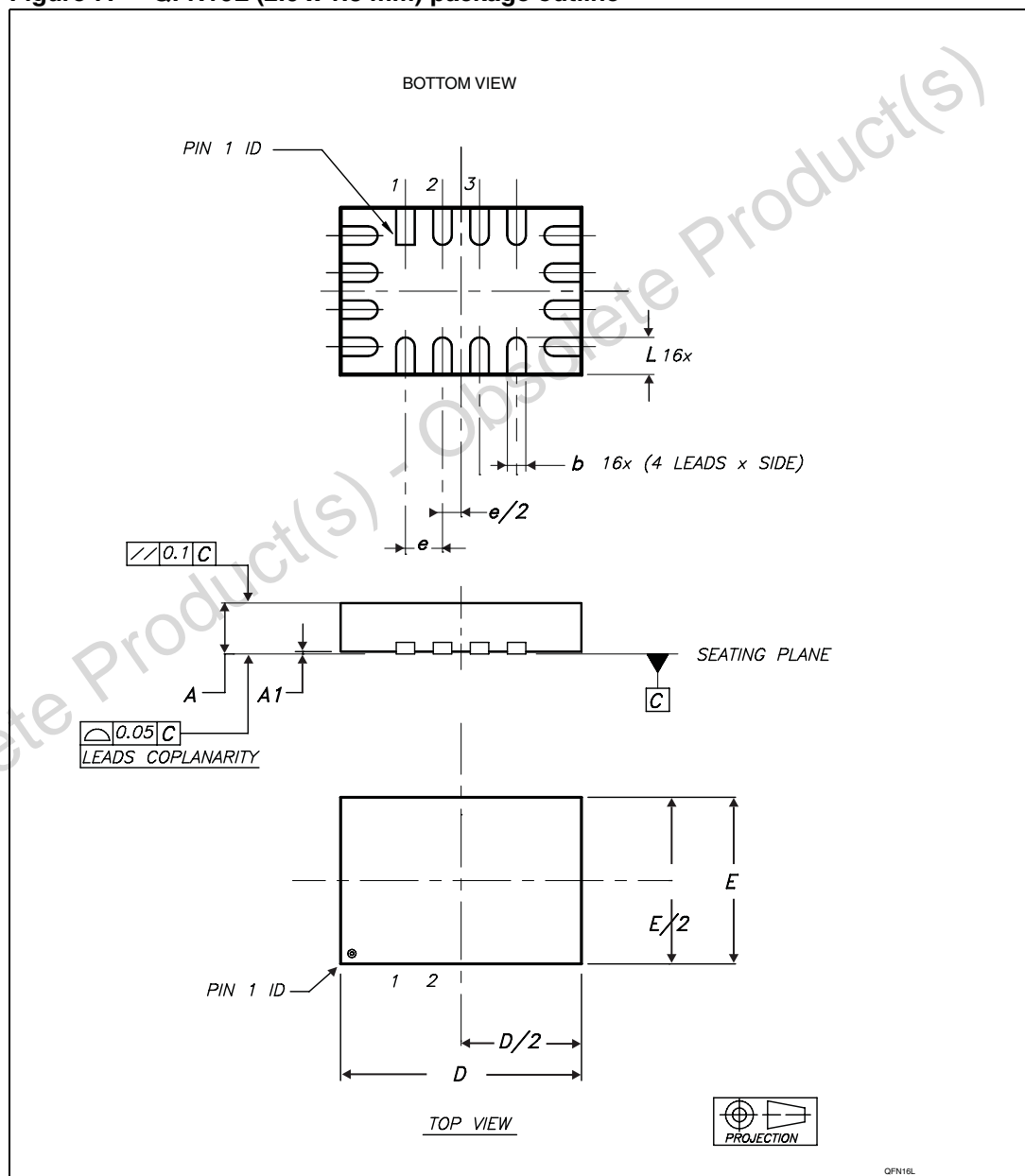

1. Drawing not to scale.
2. Dimensions are in millimeters.

ST2349

Package mechanical data

Table 15. QFN16L (2.6 x 1.8 mm) mechanical data

Symbol	Millimeters		
	Typ	Min	Max
A	0.55	0.45	0.60
A1	0.02	0	0.05
b	0.20	0.15	0.25
D	2.60	2.50	2.70
E	1.80	1.70	1.90
e	0.40		
L	0.40	0.35	0.45

Figure 8. QFN16L (2.6 x 1.8 mm) footprint recommendations

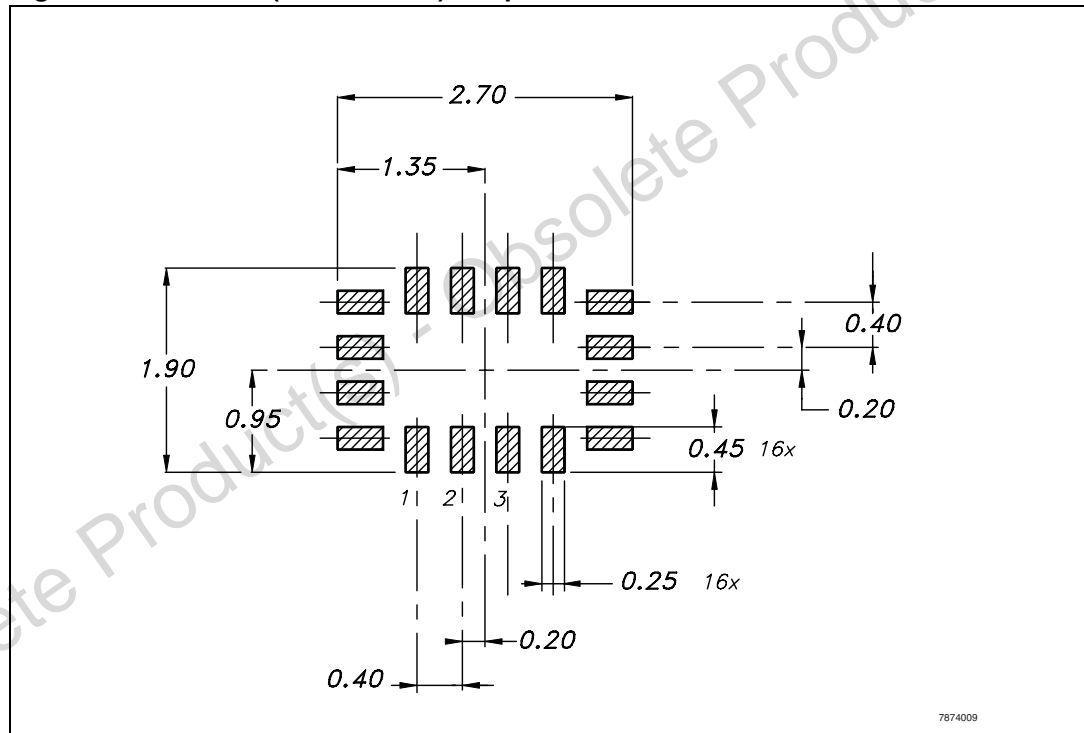

1. Drawing not to scale.
2. Dimensions are in millimeters.

Package mechanical data

ST2349

Figure 9. QFN16L (2.6 x 1.8 mm) carrier tape

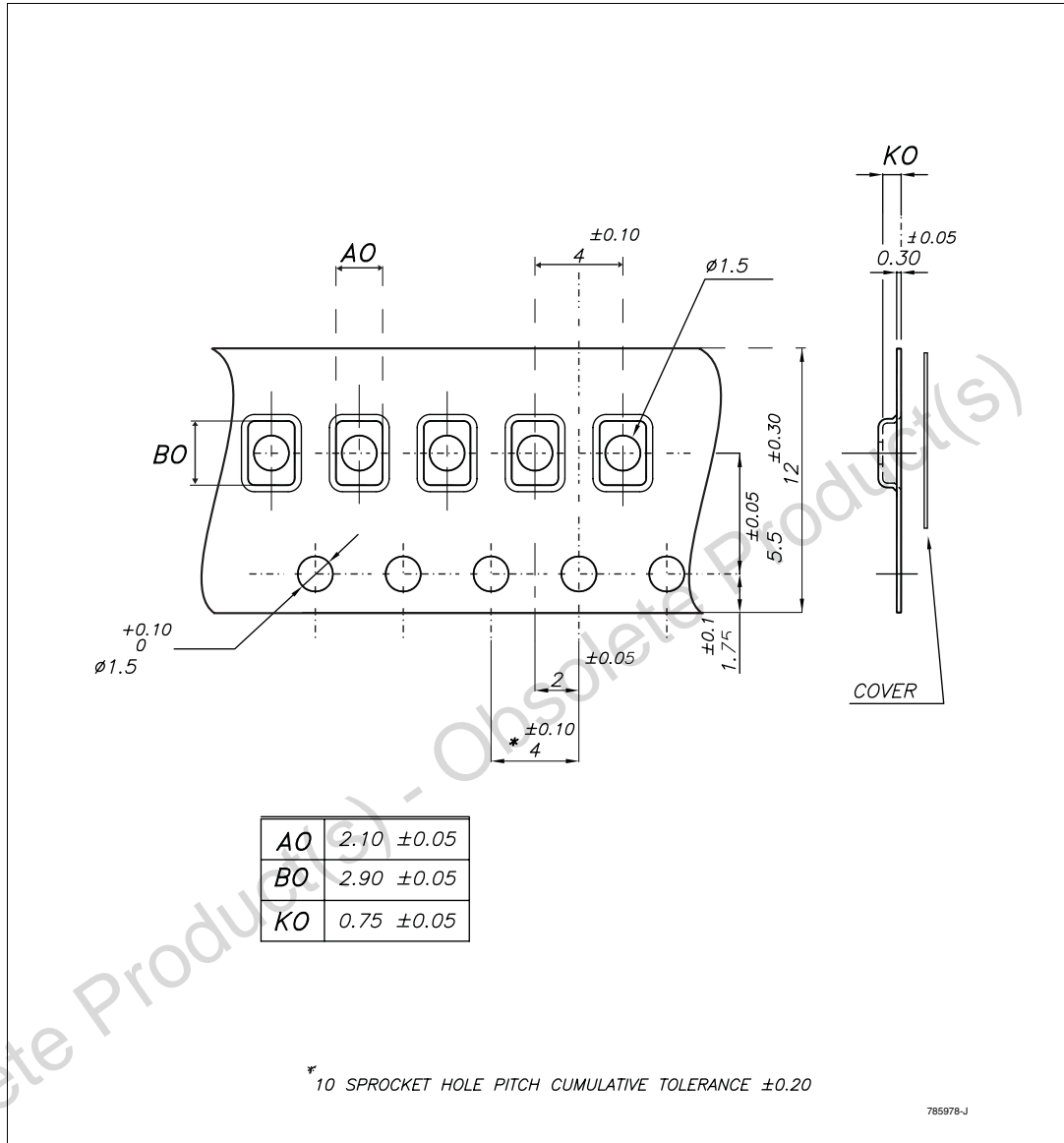

ST2349

Package mechanical data

Figure 10. QFN16L (2.6 x 1.8 mm) reel information

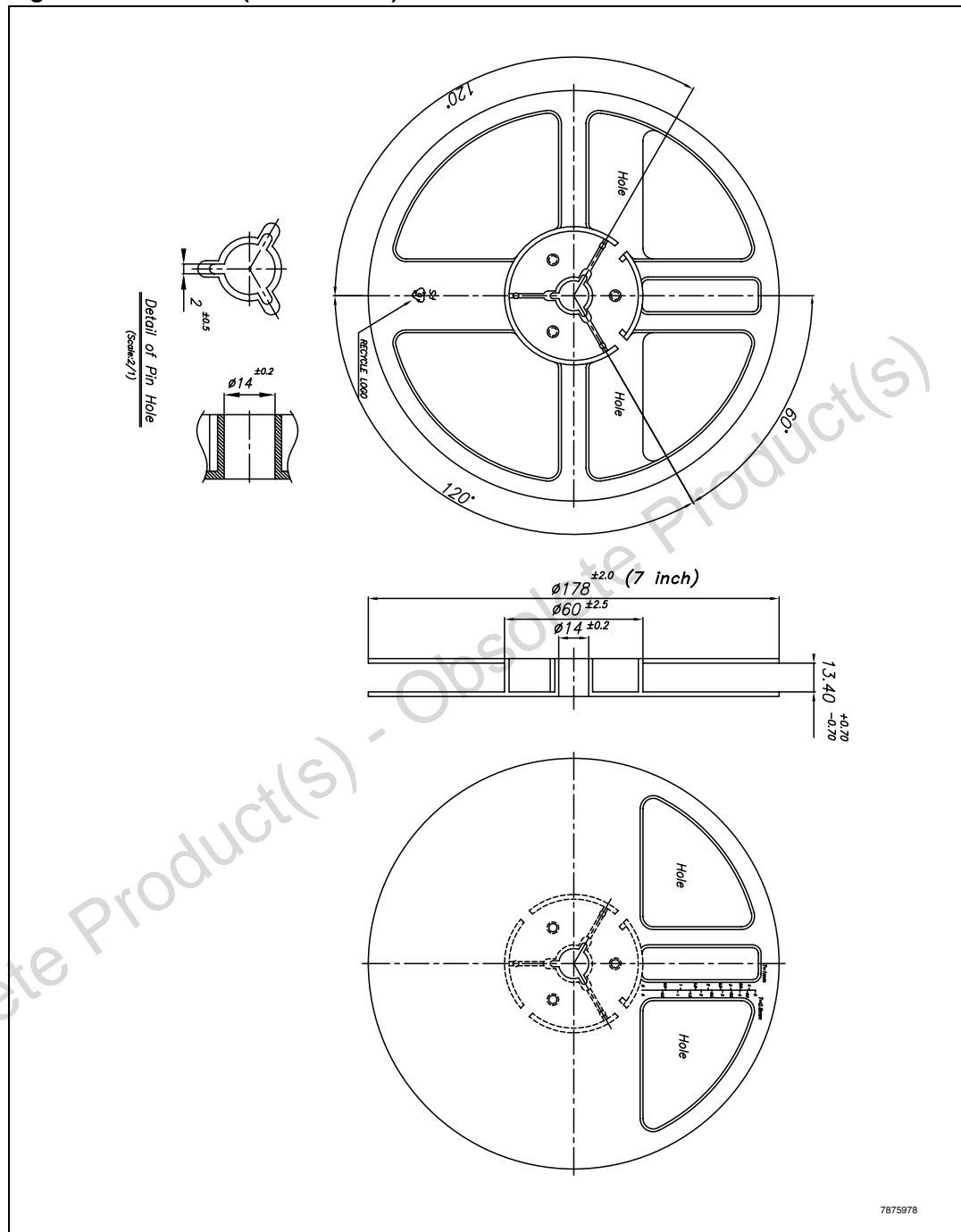

1. Drawing not to scale.
2. Dimensions are in millimeters

8 Revision history

Table 16. Document revision history

Date	Revision	Changes
07-May-2007	1	Initial release.
29-May-2007	2	Typo in cover page title.
26-Nov-2007	3	Removed Data Brief classification from the cover page. Modified title and features section, added the following sections: Section 1: Pin settings , Section 2: Device block diagrams , Section 3: Supplementary notes , Section 4: Maximum rating , Section 5: Electrical characteristics Section 6: Waveforms and updated Section 7: Package mechanical data .
07-May-2008	4	Updated data rate values and added paragraph on load driving capability (Section 3.2).

ST2349

Please Read Carefully:

Information in this document is provided solely in connection with ST products. STMicroelectronics NV and its subsidiaries ("ST") reserve the right to make changes, corrections, modifications or improvements, to this document, and the products and services described herein at any time, without notice.

All ST products are sold pursuant to ST's terms and conditions of sale.

Purchasers are solely responsible for the choice, selection and use of the ST products and services described herein, and ST assumes no liability whatsoever relating to the choice, selection or use of the ST products and services described herein.

No license, express or implied, by estoppel or otherwise, to any intellectual property rights is granted under this document. If any part of this document refers to any third party products or services it shall not be deemed a license grant by ST for the use of such third party products or services, or any intellectual property contained therein or considered as a warranty covering the use in any manner whatsoever of such third party products or services or any intellectual property contained therein.

UNLESS OTHERWISE SET FORTH IN ST'S TERMS AND CONDITIONS OF SALE ST DISCLAIMS ANY EXPRESS OR IMPLIED WARRANTY WITH RESPECT TO THE USE AND/OR SALE OF ST PRODUCTS INCLUDING WITHOUT LIMITATION IMPLIED WARRANTIES OF MERCHANTABILITY, FITNESS FOR A PARTICULAR PURPOSE (AND THEIR EQUIVALENTS UNDER THE LAWS OF ANY JURISDICTION), OR INFRINGEMENT OF ANY PATENT, COPYRIGHT OR OTHER INTELLECTUAL PROPERTY RIGHT.

UNLESS EXPRESSLY APPROVED IN WRITING BY AN AUTHORIZED ST REPRESENTATIVE, ST PRODUCTS ARE NOT RECOMMENDED, AUTHORIZED OR WARRANTED FOR USE IN MILITARY, AIR CRAFT, SPACE, LIFE SAVING, OR LIFE SUSTAINING APPLICATIONS, NOR IN PRODUCTS OR SYSTEMS WHERE FAILURE OR MALFUNCTION MAY RESULT IN PERSONAL INJURY, DEATH, OR SEVERE PROPERTY OR ENVIRONMENTAL DAMAGE. ST PRODUCTS WHICH ARE NOT SPECIFIED AS "AUTOMOTIVE GRADE" MAY ONLY BE USED IN AUTOMOTIVE APPLICATIONS AT USER'S OWN RISK.

Resale of ST products with provisions different from the statements and/or technical features set forth in this document shall immediately void any warranty granted by ST for the ST product or service described herein and shall not create or extend in any manner whatsoever, any liability of ST.

ST and the ST logo are trademarks or registered trademarks of ST in various countries.

Information in this document supersedes and replaces all information previously supplied.

The ST logo is a registered trademark of STMicroelectronics. All other names are the property of their respective owners.

© 2008 STMicroelectronics - All rights reserved

STMicroelectronics group of companies

Australia - Belgium - Brazil - Canada - China - Czech Republic - Finland - France - Germany - Hong Kong - India - Israel - Italy - Japan - Malaysia - Malta - Morocco - Singapore - Spain - Sweden - Switzerland - United Kingdom - United States of America

www.st.com