

Excellent Integrated System Limited

Stocking Distributor

Click to view price, real time Inventory, Delivery & Lifecycle Information:

[Texas Instruments](#)
[ADS8519IBDB](#)

For any questions, you can email us directly:

sales@integrated-circuit.com

16-Bit, 250kSPS, Serial, CMOS, Sampling ANALOG-TO-DIGITAL CONVERTER

Check for Samples: [ADS8519](#)

FEATURES

- 0V to 8.192V, $\pm 5V$, and $\pm 10V$ Input Ranges
- 93dB SNR with 20kHz Input
- $\pm 1.5LSB$ Max INL
- $\pm 1LSB$ Max DNL; 16 Bits, No Missing Codes
- SPI™-Compatible Serial Output with Daisy-Chain (TAG) Feature and 3-State Bus
- 5V Analog Supply, 1.65V to 5.25V I/O Supply
- Pinout Similar to 16-Bit [ADS7809](#) (Low-Speed) and 12-Bit [ADS7808](#) and [ADS8508](#)
- No External Precision Resistors Required
- Uses Internal or External Reference
- 110mW Typ Power Dissipation at 250kSPS
- 28-Pin SSOP Package
- Simple DSP Interface

APPLICATIONS

- Industrial Process Control
- Data Acquisition Systems
- Digital Signal Processing
- Medical Equipment
- Instrumentation

DESCRIPTION

The ADS8519 is a complete 16-bit sampling analog-to-digital (A/D) converter using state-of-the-art CMOS structures. It contains a complete 16-bit, capacitor-based, successive approximation register (SAR) A/D converter with sample-and-hold, reference, clock, and a serial data interface. Data can be output using the internal clock or synchronized to an external data clock. The ADS8519 also provides an output synchronization pulse for ease-of-use with standard DSP processors.

The ADS8519 is specified at a 250kSPS sampling rate over the full temperature range. Internal precision resistors provide various input ranges including $\pm 10V$, $\pm 5V$, and 0V to 8.192V, while the innovative design allows operation from a single 5V supply with power dissipation under 125mW.

The ADS8519 is available in a 28-pin SSOP package, and is fully specified for operation over the industrial $-40^{\circ}C$ to $+85^{\circ}C$ temperature range.

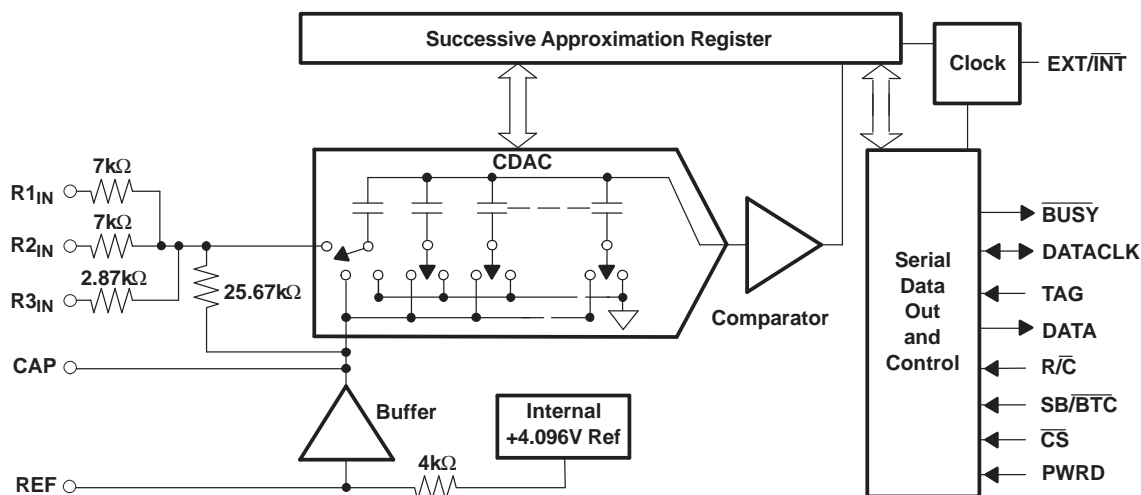

Please be aware that an important notice concerning availability, standard warranty, and use in critical applications of Texas Instruments semiconductor products and disclaimers thereto appears at the end of this data sheet.

SPI is a trademark of Motorola, Inc.

All other trademarks are the property of their respective owners.

PRODUCTION DATA information is current as of publication date. Products conform to specifications per the terms of the Texas Instruments standard warranty. Production processing does not necessarily include testing of all parameters.

Copyright © 2007–2010, Texas Instruments Incorporated



This integrated circuit can be damaged by ESD. Texas Instruments recommends that all integrated circuits be handled with appropriate precautions. Failure to observe proper handling and installation procedures can cause damage.

ESD damage can range from subtle performance degradation to complete device failure. Precision integrated circuits may be more susceptible to damage because very small parametric changes could cause the device not to meet its published specifications.

PACKAGE/ORDERING INFORMATION⁽¹⁾

PRODUCT	MINIMUM INL (LSB)	NO MISSING CODES	MINIMUM SINAD (dB)	SPECIFIED TEMPERATURE RANGE	PACKAGE-LEAD	PACKAGE DESIGNATOR	ORDERING NUMBER	TRANSPORT MEDIA, QTY
ADS8519IB	±1.5	16-Bit	90	–40°C to +85°C	SSOP-28	DB	ADS8519IBDB	Tube, 50
							ADS8519IBDBR	Tape and Reel, 2000
ADS8519I	±3	15-Bit	87	–40°C to +85°C	SSOP-28	DB	ADS8519IDB	Tube, 50
							ADS8519IDBR	Tape and Reel, 2000

(1) For the most current package and ordering information, see the Package Option Addendum at the end of this document, or see the TI website at www.ti.com.

ABSOLUTE MAXIMUM RATINGS^{(1) (2)}

Over operating free-air temperature range (unless otherwise noted).

		UNIT
Analog inputs	R _{1IN}	±25V
	R _{2IN}	±25V
	R _{3IN}	±25V
	REF	+V _{ANA} + 0.3V to AGND2 – 0.3V
Ground voltage differences	DGND, AGND2	±0.3V
	V _{ANA}	6V
	V _{DIG}	6V
Digital inputs		–0.3V to +V _{DIG} + 0.3V
Internal power dissipation		700mW
Maximum junction temperature		+165°C
Lead temperature (soldering, 10s)		+300°C

- (1) Stresses above those listed under *Absolute Maximum Ratings* may cause permanent damage to the device. Exposure to absolute maximum conditions for extended periods may affect device reliability.
 (2) All voltage values are with respect to network ground terminal.

ELECTRICAL CHARACTERISTICS

At T_A = –40°C to +85°C, f_s = 250kSPS, and V_{DIG} = V_{ANA} = 5V, using internal reference (unless otherwise specified).

PARAMETER	TEST CONDITIONS	ADS8519I			ADS8519IB			UNIT
		MIN	TYP	MAX	MIN	TYP	MAX	
Resolution				16			16	Bits
ANALOG INPUT								
Voltage ranges ⁽¹⁾								
Impedance ⁽¹⁾								
Capacitance			50			50		pF
THROUGHPUT SPEED								
Conversion cycle time	Acquire and convert			4			4	µs
Throughput rate		250			250			kSPS

(1) ±10V, ±5V, 0V to 8.192V, etc. (see Table 2)

ELECTRICAL CHARACTERISTICS (continued)

At $T_A = -40^\circ\text{C}$ to $+85^\circ\text{C}$, $f_s = 250\text{kSPS}$, and $V_{\text{DIG}} = V_{\text{ANA}} = 5\text{V}$, using internal reference (unless otherwise specified).

PARAMETER	TEST CONDITIONS	ADS8519I			ADS8519IB			UNIT		
		MIN	TYP	MAX	MIN	TYP	MAX			
DC ACCURACY										
INL	Integral linearity error		-3		3		-1.5	1.5	LSB ⁽²⁾	
DNL	Differential linearity error		-2		2		-1	1	LSB	
	No missing codes		15				16		Bits	
	Transition noise ⁽³⁾			0.67			0.67		LSB	
Full-scale error ^{(4) (5)}	$\pm 10\text{V}$ range	Internal reference	-0.5		0.5		-0.25	0.25	%FSR	
	All other ranges	Internal reference	-0.5	-0.05	0.5		-0.5	-0.05		0.5
	Full-scale error drift	Internal reference		± 7			± 7		ppm/ $^\circ\text{C}$	
Full-scale error ^{(4) (5)}	$\pm 10\text{V}$ range	External reference	-0.05	0.003	0.05		-0.05	0.003	0.05	%FSR
	All other ranges	External reference	-0.5		0.5		-0.5		0.5	
	Full-scale error drift	External reference		± 2			± 2		ppm/ $^\circ\text{C}$	
	Bipolar zero error ⁽⁴⁾		-4		4		-2	2	mV	
	Bipolar zero error drift			± 2			± 2		ppm/ $^\circ\text{C}$	
Unipolar zero error ⁽⁴⁾	8.192V		-20	6	20		-20	6	20	mV
	Unipolar zero error drift			± 0.4			± 0.4		ppm/ $^\circ\text{C}$	
	Recovery to rated accuracy after power down	1 μF capacitor to CAP		1			1		ms	
	Power supply sensitivity ($V_{\text{DIG}} = V_{\text{ANA}} = V_{\text{D}}$)	+4.75V < V_{D} < +5.25V		-8		8	-8		8	LSB
AC ACCURACY										
SFDR	Spurious-free dynamic range	$f_i = 20\text{kHz}$	95	100			97	100	dB ⁽⁶⁾	
THD	Total harmonic distortion	$f_i = 20\text{kHz}$		-96	-94		-98	-96	dB	
SINAD	Signal-to-(noise+distortion)	$f_i = 20\text{kHz}$	87	91			90	92	dB	
		-60dB Input		30			32		dB	
SNR	Signal-to-noise ratio	$f_i = 20\text{kHz}$	88	92			91	93	dB	
	Full-power bandwidth ⁽⁷⁾			500			500		kHz	
SAMPLING DYNAMICS										
	Aperture delay			5			5		ns	
	Transient response	FS step			2			2	μs	
	Overvoltage recovery ⁽⁸⁾			150			150		ns	
REFERENCE										
	Internal reference voltage	No load	4.076	4.096	4.116		4.076	4.096	4.116	V
	Internal reference source current (must use external buffer)			1			1			μA
	Internal reference drift			8			8			ppm/ $^\circ\text{C}$
	External reference voltage range for specified linearity		3.9	4.096	4.2		3.9	4.096	4.2	V
	External reference current drain	External 4.096V ref.			100			100		μA

- (2) LSB means Least Significant Bit. For the $\pm 10\text{V}$ input range, one LSB is $305\mu\text{V}$.
- (3) Typical rms noise at worst-case transitions and temperatures.
- (4) As measured with circuit shown in Figure 29 and Figure 30.
- (5) For bipolar input ranges, full-scale error is the worst case of -Full-Scale or +Full-Scale uncalibrated deviation from ideal first and last code transitions, divided by the transition voltage (not divided by the full-scale range) and includes the effect of offset error. For unipolar input ranges, full-scale error is the deviation of the last code transition divided by the transition voltage. It also includes the effect of offset error.
- (6) All specifications in dB are referred to a full-scale $\pm 10\text{V}$ input.
- (7) Full-power bandwidth is defined as the full-scale input frequency at which signal-to-(noise + distortion) degrades to 60dB.
- (8) Recovers to specified performance after 2 x FS input overvoltage.

ELECTRICAL CHARACTERISTICS (continued)

At $T_A = -40^\circ\text{C}$ to $+85^\circ\text{C}$, $f_s = 250\text{kSPS}$, and $V_{\text{DIG}} = V_{\text{ANA}} = 5\text{V}$, using internal reference (unless otherwise specified).

PARAMETER	TEST CONDITIONS	ADS8519I			ADS8519IB			UNIT	
		MIN	TYP	MAX	MIN	TYP	MAX		
DIGITAL INPUTS									
Logic levels									
V_{IL}	Low-level input voltage ⁽⁹⁾	$V_{\text{DIG}} = 1.65\text{V to } 5.25\text{V}$	-0.3		0.6	-0.3		0.6	V
V_{IH}	High-level input voltage ⁽⁹⁾	$V_{\text{DIG}} = 1.65\text{V to } 5.25\text{V}$	$0.5 \times V_{\text{DIG}}$		$V_{\text{DIG}} + 0.3$	$0.5 \times V_{\text{DIG}}$		$V_{\text{DIG}} + 0.3$	V
I_{IL}	Low-level input current	$V_{\text{IL}} = 0\text{V}$			± 10			± 10	μA
I_{IH}	High-level input current	$V_{\text{IH}} = 5\text{V}$			± 10			± 10	μA
DIGITAL OUTPUTS									
Data format									
Serial, 16-bits									
Data coding									
Binary 2's complement or straight binary									
Pipeline delay									
Conversion results only available after completed conversion									
Data clock									
Selectable for internal or external data clock									
Internal clock (output only when transmitting data)									
$\text{EXT}/\overline{\text{INT}}$ low									
9									
MHz									
External clock (can run continually but not recommended for optimum performance)									
$\text{EXT}/\overline{\text{INT}}$ high									
0.1									
26									
MHz									
V_{OL}	Low-level output voltage	$I_{\text{SINK}} = 1.6\text{mA}$, $V_{\text{DIG}} = 1.65\text{V to } 5.25\text{V}$			0.45			0.45	V
V_{OH}	High-level output voltage	$I_{\text{SOURCE}} = 500\mu\text{A}$, $V_{\text{DIG}} = 1.65\text{V to } 5.25\text{V}$	$V_{\text{DIG}} - 0.45$			$V_{\text{DIG}} - 0.45$			V
Leakage current									
Hi-Z state, $V_{\text{OUT}} = 0\text{V to } V_{\text{DIG}}$									
± 5									
μA									
Output capacitance									
Hi-Z state									
15									
15									
pF									
POWER SUPPLIES									
V_{DIG}	Digital input voltage	Must be $\leq V_{\text{ANA}}$	1.65		5.25	1.65		5.25	V
V_{ANA}	Analog input voltage	Must be $\leq V_{\text{ANA}}$	4.75	5	5.25	4.75	5	5.25	V
I_{DIG}	Digital input current	Must be $\leq V_{\text{ANA}}$		0.1	1	0.1		1	mA
I_{ANA}	Analog input current	Must be $\leq V_{\text{ANA}}$		22	25	22		25	mA
POWER DISSIPATION									
PWRD Low									
$f_s = 250\text{kSPS}$									
110									
125									
mW									
PWRD High									
20									
20									
μW									
TEMPERATURE RANGE									
Specified performance									
-40									
+85									
$^\circ\text{C}$									
Derated performance ⁽¹⁰⁾									
-55									
+125									
$^\circ\text{C}$									
Storage									
-65									
+150									
$^\circ\text{C}$									
θ_{JA}	Thermal resistance			67				67	$^\circ\text{C/W}$

(9) TTL-compatible at 5V supply.

(10) The internal reference may not be started correctly beyond the industrial temperature range (-40°C to $+85^\circ\text{C}$); therefore, use of an external reference is recommended.

PIN CONFIGURATION

**DB PACKAGE
 (TOP VIEW)**

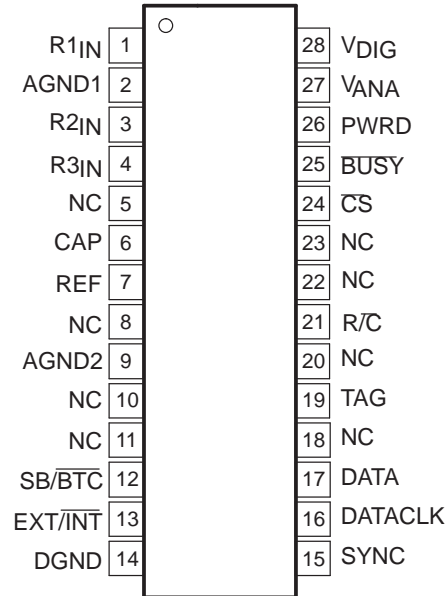

Pin Assignments

PIN		I/O	DESCRIPTION
NAME	NO.		
AGND1	2	–	Analog ground. Used internally as ground reference point. Minimal current flow.
AGND2	9	–	Analog ground
$\overline{\text{BUSY}}$	25	O	Busy output. Falls when a conversion is started, and remains low until the conversion is completed and the data are latched into the output shift register.
$\overline{\text{CS}}$	24	–	Chip select. Internally ORed with $\overline{\text{R/C}}$.
CAP	6		Reference buffer capacitor, 2.2 μ F tantalum capacitor to ground.
DATA	17	O	Serial data output. Data are synchronized to DATACLK, with the format determined by the level of SB/BTC. In the external clock mode, after 16 bits of data, the ADS8519 outputs the level input on TAG as long as $\overline{\text{CS}}$ is low and $\overline{\text{R/C}}$ is high (see Figure 8 and Figure 9). If EXT/INT is low, data are valid on both the rising and falling edges of DATACLK, and between conversions DATA stays at the level of the TAG input when the conversion was started.
DATACLK	16	I/O	Either an input or an output, depending on the EXT/INT level. Output data are synchronized to this clock. If EXT/INT is low, DATACLK transmits 16 pulses after each conversion, and then remains low between conversions.
DGND	14	–	Digital ground
EXT/INT	13	–	Selects external or internal clock for transmitting data. If high, data are output synchronized to the clock input on DATACLK. If low, a convert command initiates the transmission of the data from the previous conversion, along with 16 clock pulses output on DATACLK.
NC	5, 8, 10, 11, 18, 20, 22, 23	–	Not connected
PWRD	26	I	Power down input. If high, conversions are inhibited and power consumption is significantly reduced. Results from the previous conversion are maintained in the output shift register.
$\overline{\text{R/C}}$	21	I	Read/convert input. With $\overline{\text{CS}}$ low, a falling edge on $\overline{\text{R/C}}$ puts the internal sample-and-hold into the hold state and starts a conversion. When EXT/INT is low, this also initiates the transmission of the data results from the previous conversion. If EXT/INT is high, a rising edge on $\overline{\text{R/C}}$ with $\overline{\text{CS}}$ low, or a falling edge on $\overline{\text{CS}}$ with $\overline{\text{R/C}}$ high, initiates the transmission of data from the previous conversion.
REF	7	I/O	Reference input/output. Outputs internal 4.096V reference. Can also be driven by external system reference. In both cases, bypass to ground with a 2.2 μ F tantalum capacitor.
R1IN	1	I	Analog input. See Table 2 for input range connections.
R2IN	3	I	Analog input. See Table 2 for input range connections.
R3IN	4	I	Analog input. See Table 2 for input range connections.
SB/BTC	12	I	Select straight binary or binary two's complement data output format. If high, data are output in a straight binary format. If low, data are output in a binary two's complement format.
SYNC	15	O	Sync output. This pin is used to supply a data synchronization pulse when the EXT level is high and at least one external clock pulse has occurred when not in the read mode. See the External DATACLK section for the external clock mode description.
TAG	19	I	Tag input for use in the external clock mode. If EXT is high, digital data input from TAG is output on DATA with a delay that depends on the external clock mode. See Figure 8 and Figure 9.
VANA	27	I	Analog supply input. Nominally +5V. Connect directly to pin 20, and decouple to ground with 0.1 μ F ceramic and 10 μ F tantalum capacitors.
VDIG	28	I	Digital supply input. Connect directly to pin 19.

TIMING REQUIREMENTS, $T_A = -40^{\circ}\text{C}$ to $+85^{\circ}\text{C}$

PARAMETER		MIN	TYP	MAX	UNIT
t_{w1}	Pulse duration, convert	40			ns
t_{d1}	Delay time, $\overline{\text{BUSY}}$ from $\text{R}/\overline{\text{C}}$ low		6	20	ns
t_{w2}	Pulse duration, $\overline{\text{BUSY}}$ low			2.2	μs
t_{d2}	Delay time, $\overline{\text{BUSY}}$, after end of conversion		5		ns
t_{d3}	Delay time, aperture		5		ns
t_{conv}	Conversion time			2.2	μs
t_{acq}	Acquisition time	1.8			μs
$t_{\text{conv}} + t_{\text{acq}}$	Cycle time			4	μs
t_{d4}	Delay time, $\text{R}/\overline{\text{C}}$ Low to internal DATACLK output		270		ns
t_{c1}	Cycle time, internal DATACLK		110		ns
t_{d5}	Delay time, data valid to internal DATACLK high	15	35		ns
t_{d6}	Delay time, data valid after internal DATACLK low	20	35		ns
t_{c2}	Cycle time, external DATACLK	35			ns
t_{w3}	Pulse duration, external DATACLK high	15			ns
t_{w4}	Pulse duration, external DATACLK low	15			ns
t_{su1}	Setup time, $\text{R}/\overline{\text{C}}$ rise/fall to external DATACLK high	15			ns
t_{su2}	Setup time, $\text{R}/\overline{\text{C}}$ transition to $\overline{\text{CS}}$ transition	10			ns
t_{d7}	Delay time, SYNC, after external DATACLK high	3		35	ns
t_{d8}	Delay time, data valid from external DATACLK high	2		13	ns
t_{d9}	Delay time, $\overline{\text{CS}}$ rising edge to external DATACLK rising edge	10			ns
t_{d10}	Delay time, previous data available after $\overline{\text{CS}}$, $\text{R}/\overline{\text{C}}$ low	2			μs
t_{su3}	Setup time, $\overline{\text{BUSY}}$ transition to first external DATACLK	5			ns
t_{d11}	Delay time, final external DATACLK to $\overline{\text{BUSY}}$ rising edge			1	μs
t_{su4}	Setup time, TAG valid	0			ns
t_{h1}	Hold time, TAG valid	2			ns

TIMING DIAGRAMS

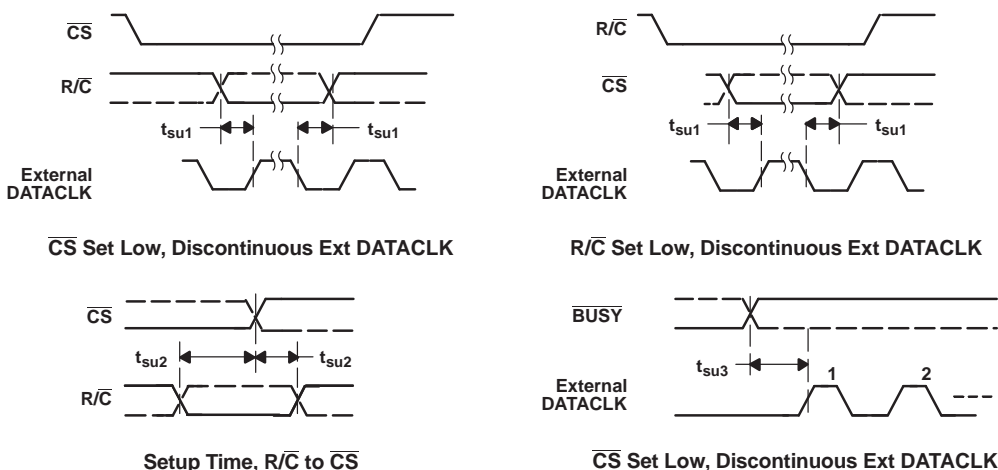

Figure 1. Critical Timing

TIMING DIAGRAMS (continued)

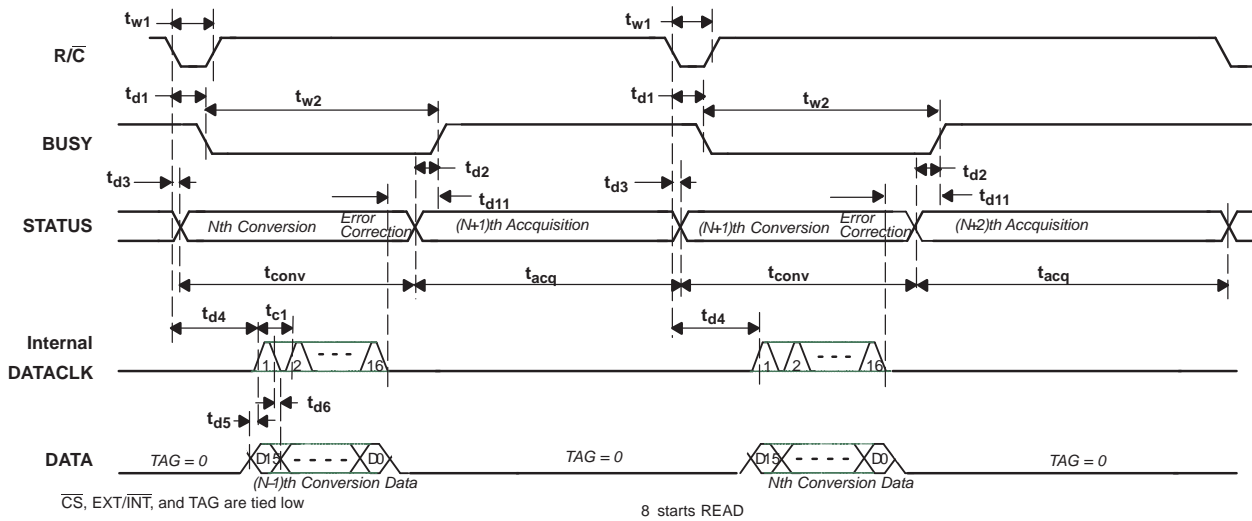

Figure 2. Basic Conversion Timing: Internal DATACLK (Read Previous Data During Conversion)

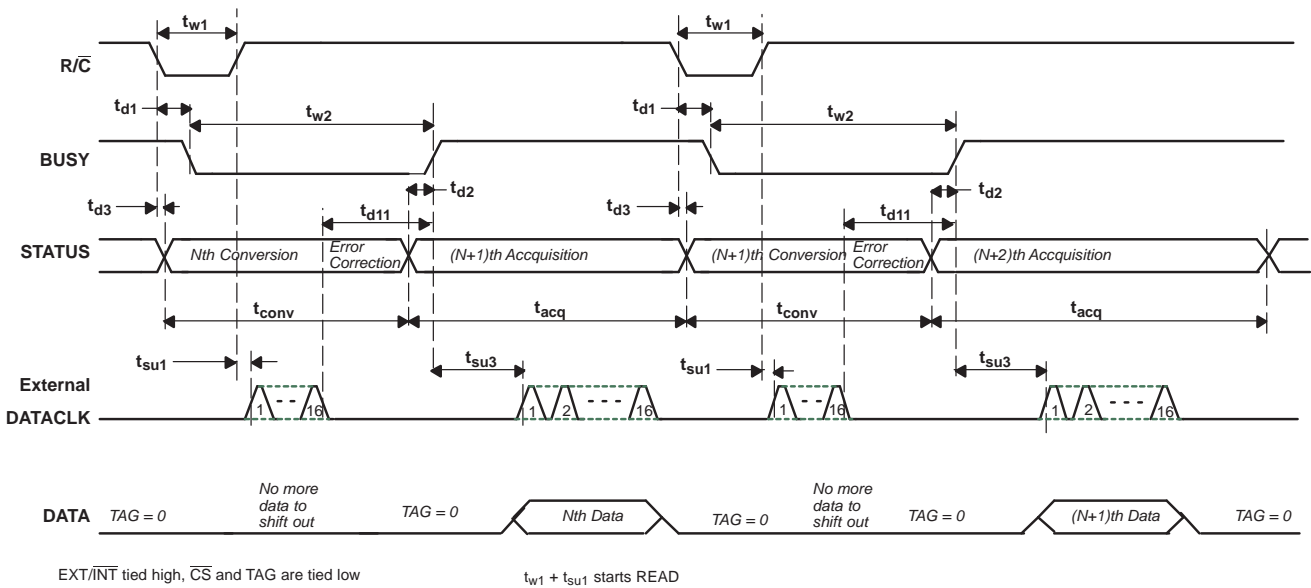

Figure 3. Basic Conversion Timing: External DATACLK

TIMING DIAGRAMS (continued)

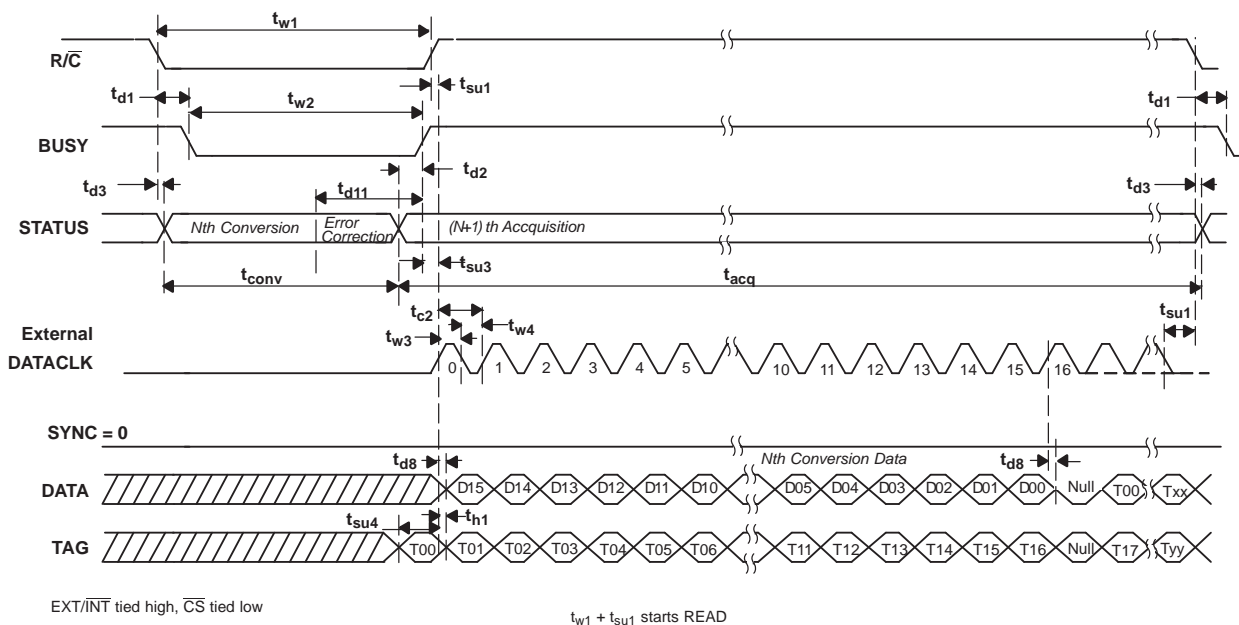

Figure 4. Read After Conversion (Discontinuous External DATACLK)

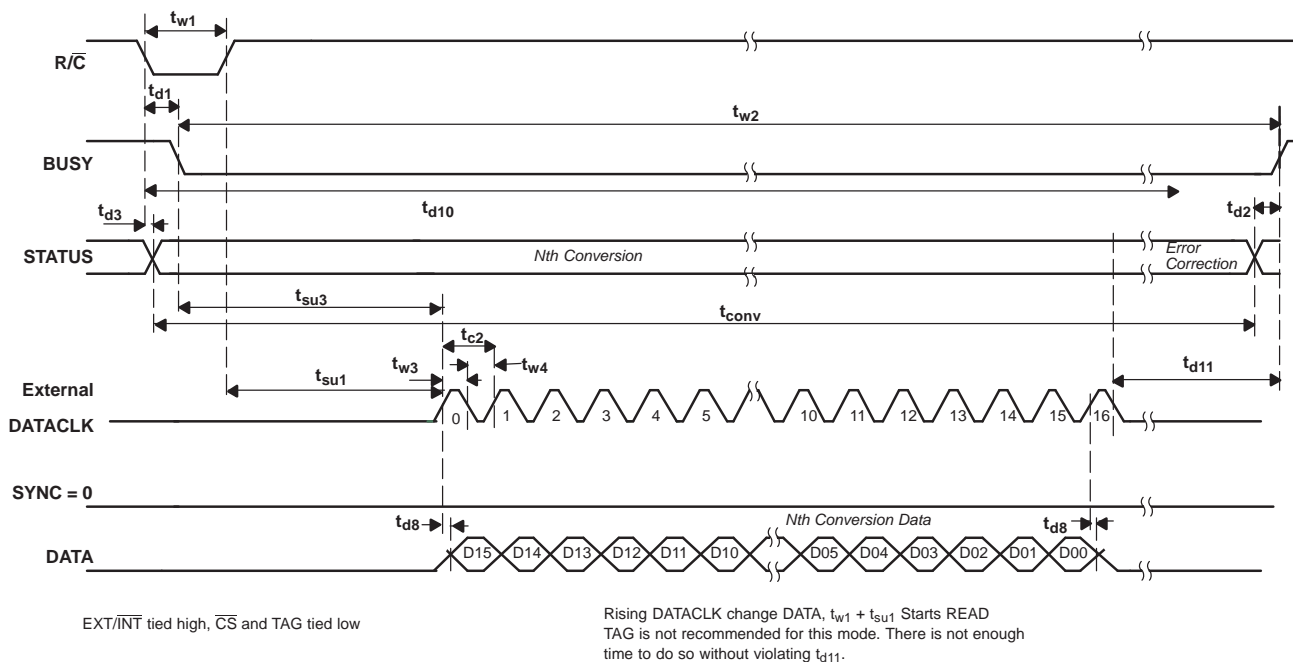

Figure 5. Read During Conversion (Discontinuous External DATACLK)

TIMING DIAGRAMS (continued)

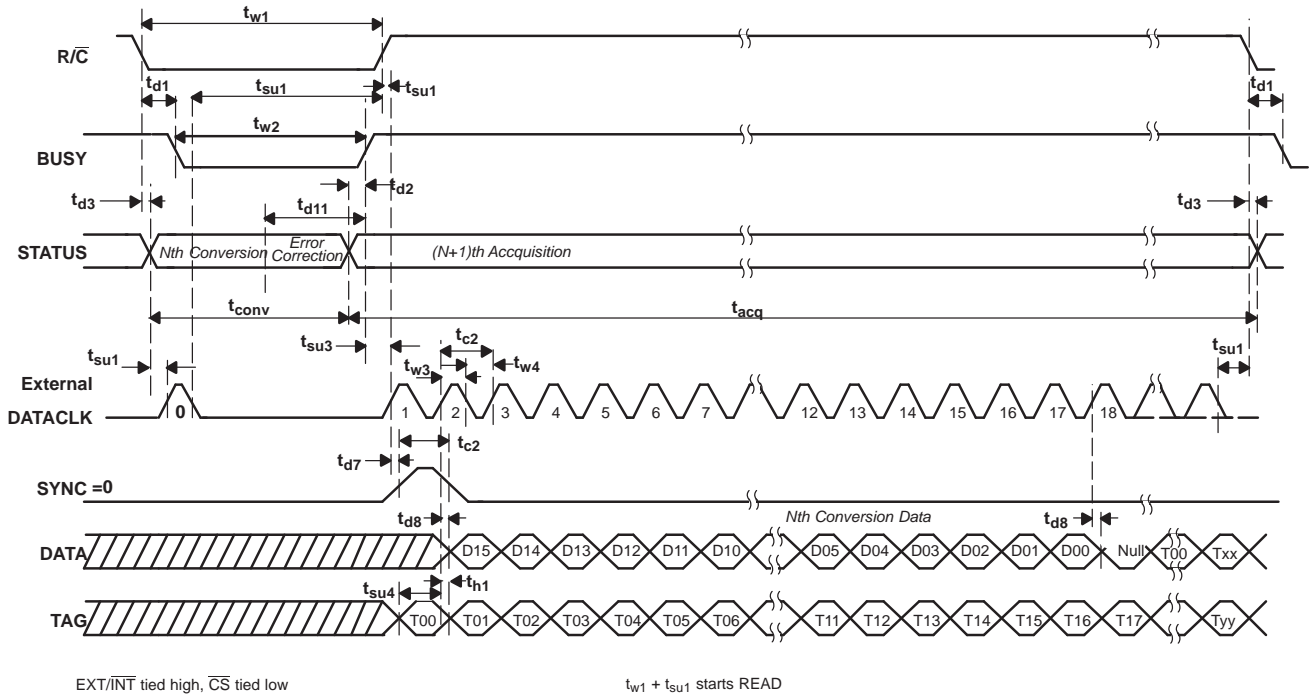

Figure 6. Read After Conversion With SYNC (Discontinuous External DATACLK)

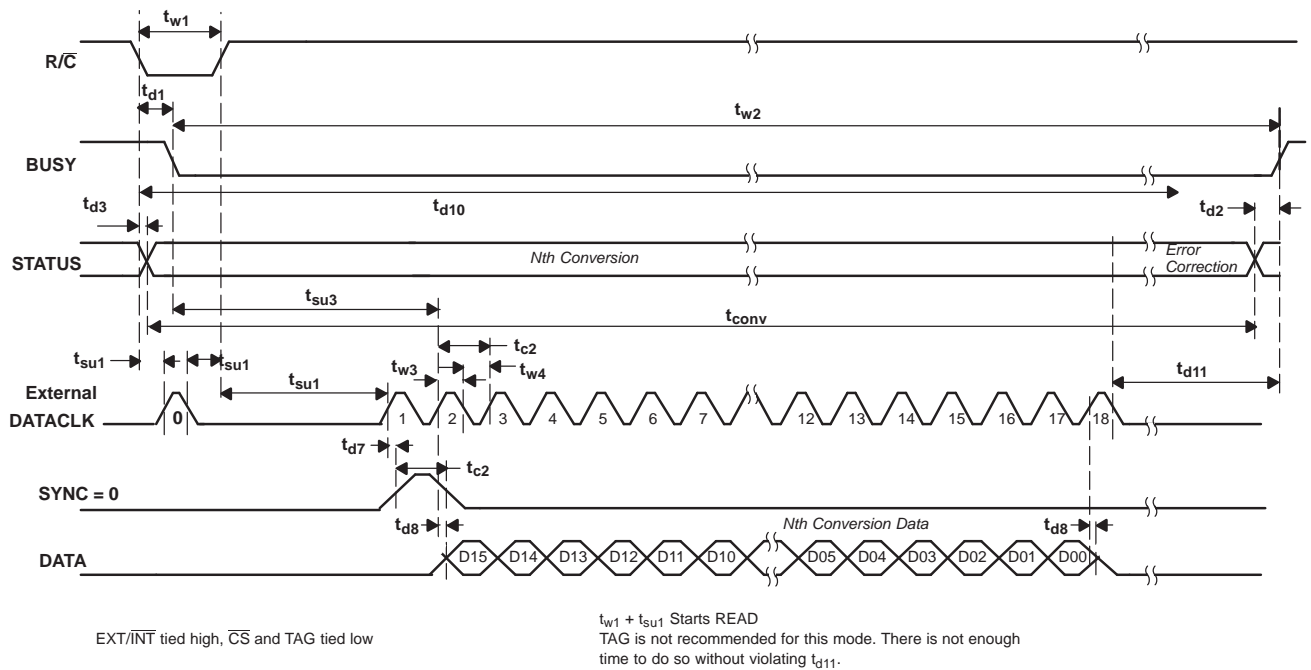

Figure 7. Read During Conversion With SYNC (Discontinuous External DATACLK)

TIMING DIAGRAMS (continued)

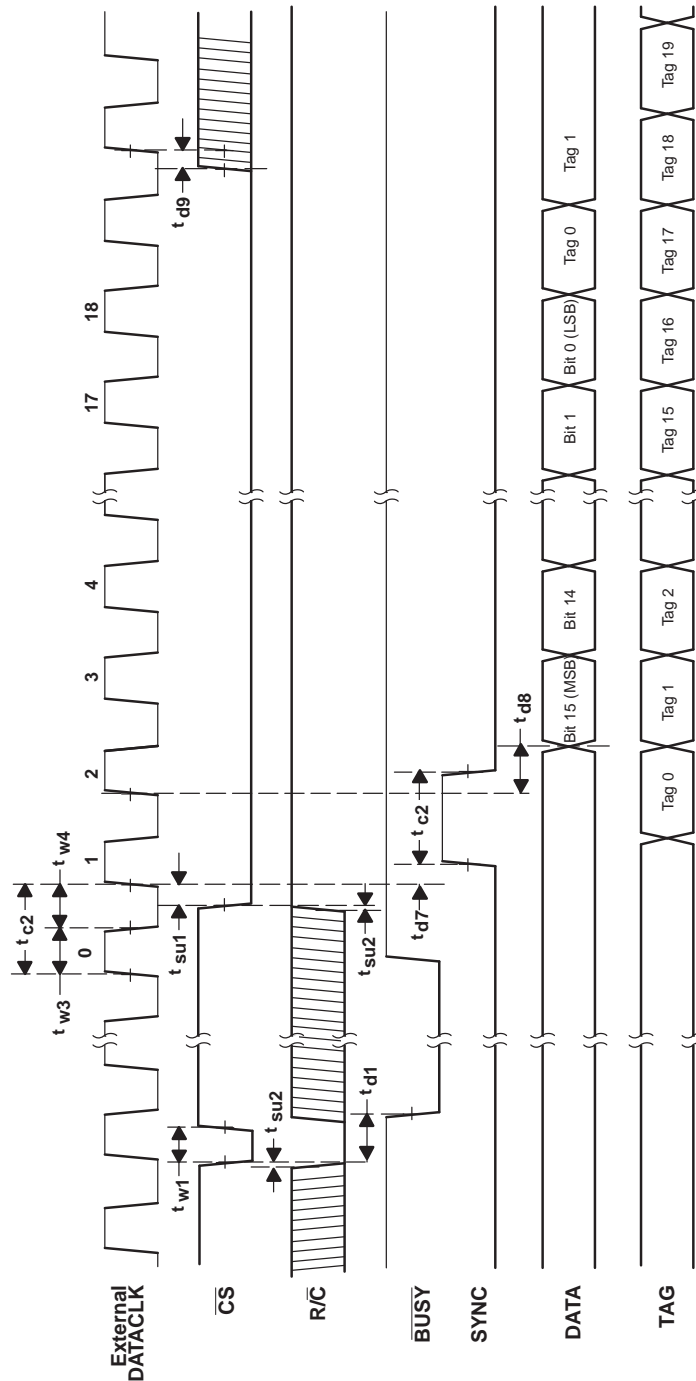

Figure 8. Conversion and Read Timing with Continuous External DATACLK (EXT/INT Tied High) Read After Conversions (Not Recommended)

TIMING DIAGRAMS (continued)

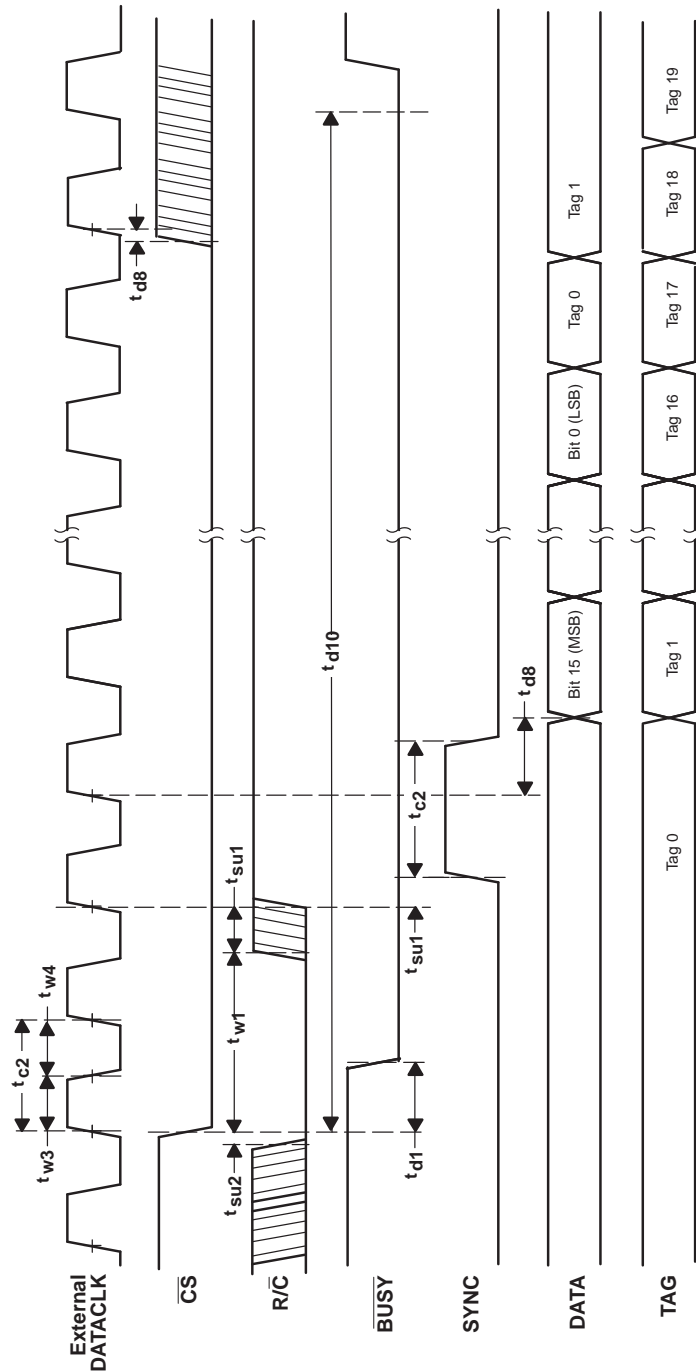

Figure 9. Conversion and Read Timing with Continuous External DATACLK (EXT/INT Tied High) Read Previous Conversion Results During Conversion (Not Recommended)

TYPICAL CHARACTERISTICS

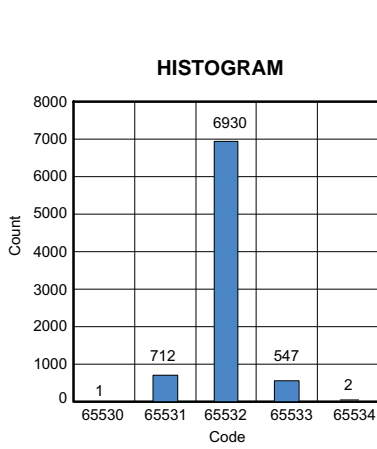

Figure 10.

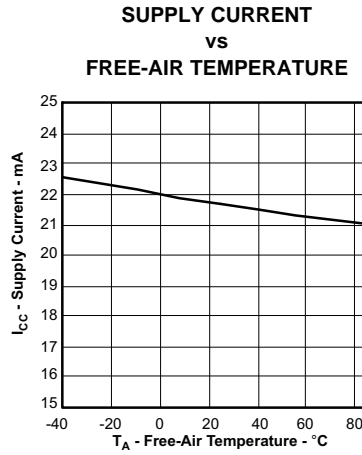

Figure 11.

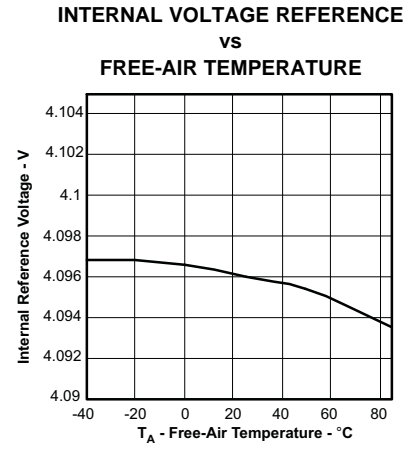

Figure 12.

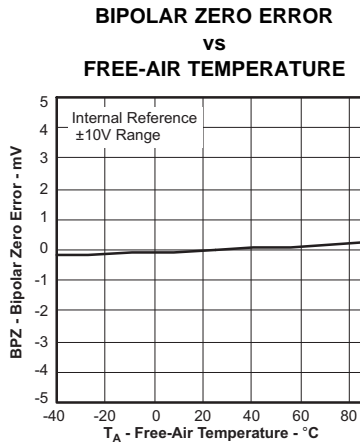

Figure 13.

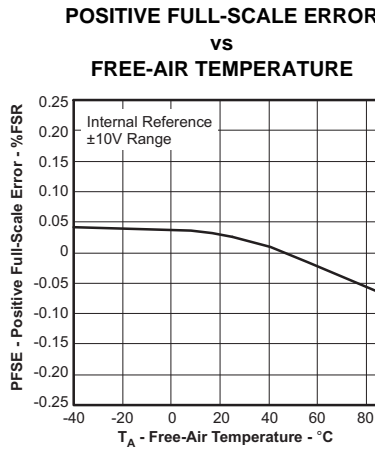

Figure 14.

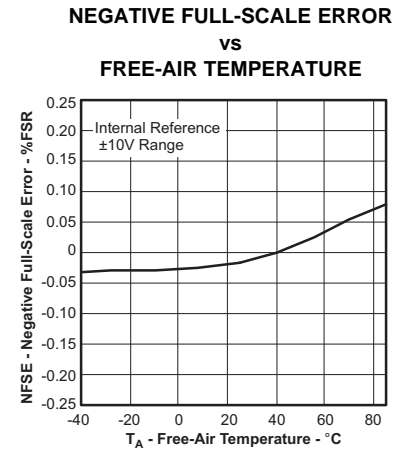

Figure 15.

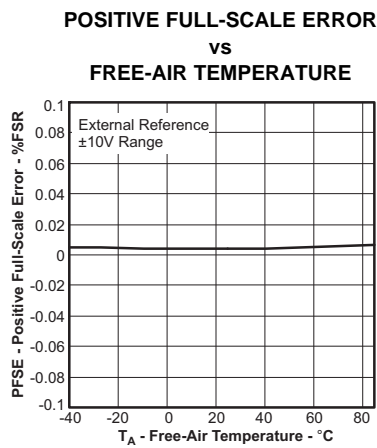

Figure 16.

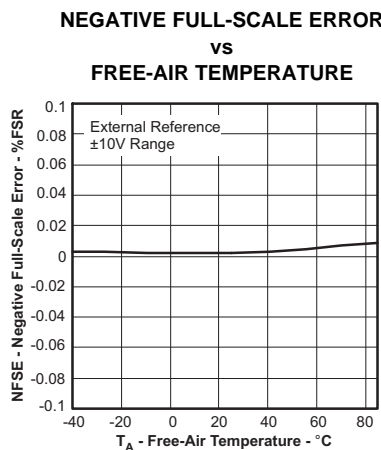

Figure 17.

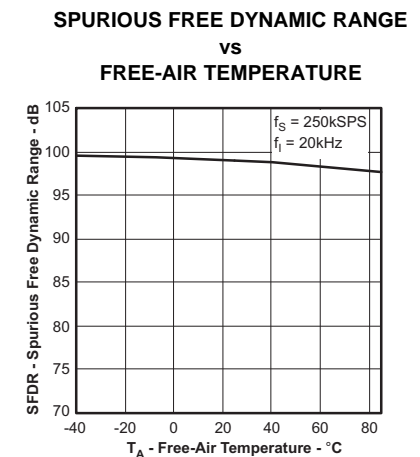

Figure 18.

TYPICAL CHARACTERISTICS (continued)

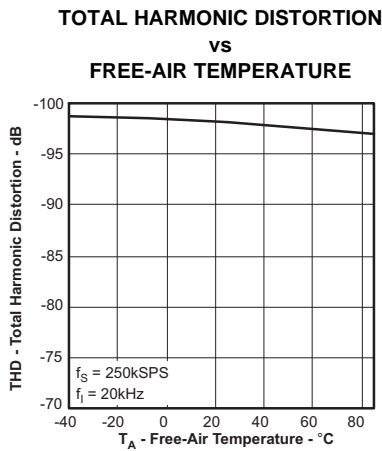

Figure 19.

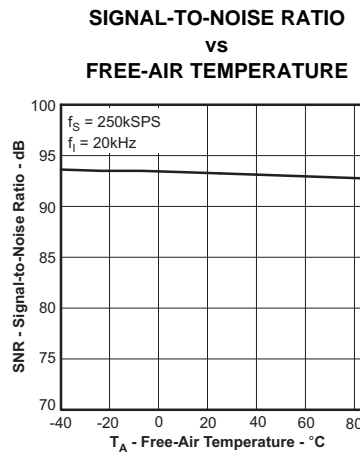

Figure 20.

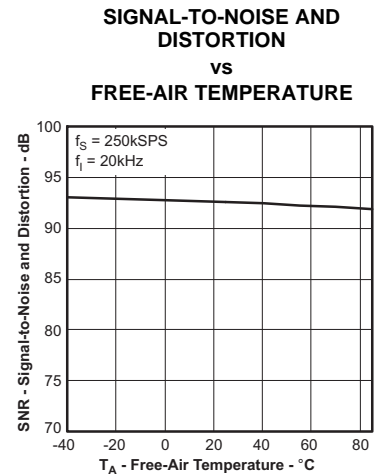

Figure 21.

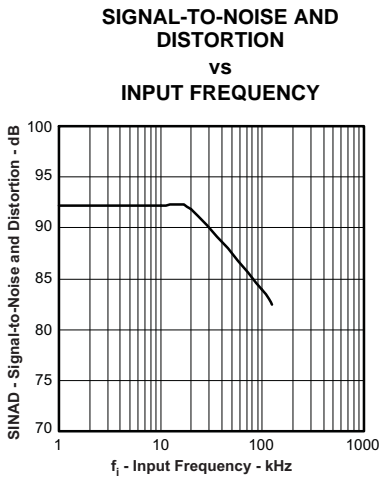

Figure 22.

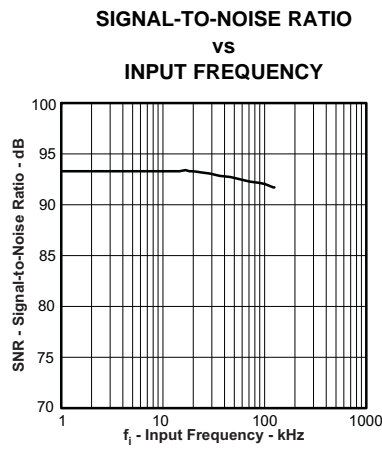

Figure 23.

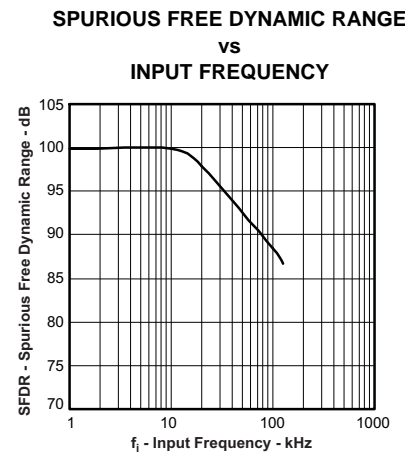

Figure 24.

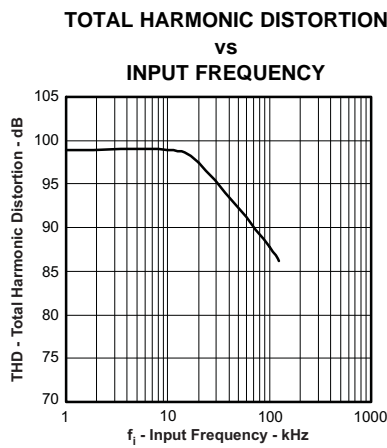

Figure 25.

TYPICAL CHARACTERISTICS (continued)

INL

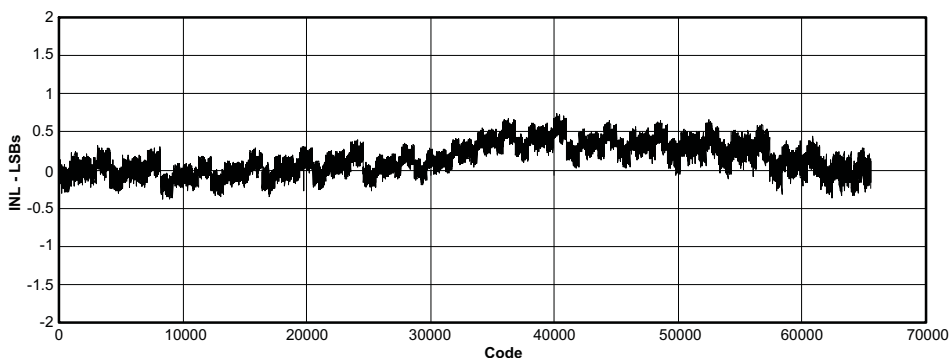

Figure 26.

DNL

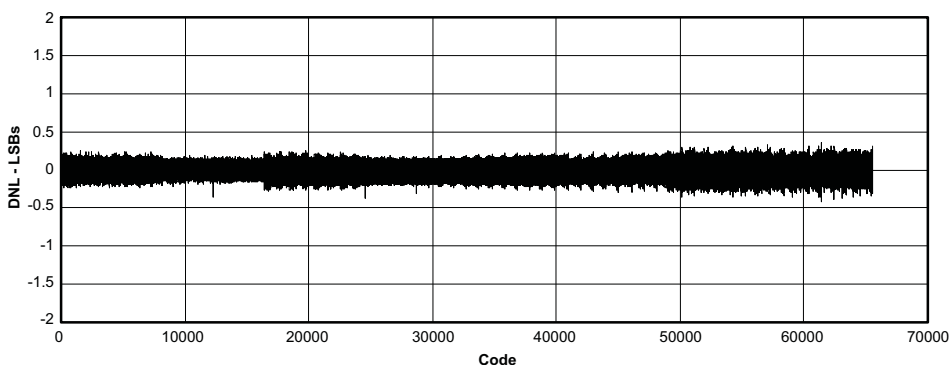

Figure 27.

BASIC OPERATION

Two signals control conversion in the ADS8519: \overline{CS} and R/\overline{C} . These two signals are internally ORed together. To start a conversion, the chip must be selected (\overline{CS} low) and the conversion signal must be active (R/\overline{C} low). Either signal can be brought low first. Conversion starts on the falling edge of the second signal. $BUSY$ goes low when conversion starts and returns high after the data from that conversion are shifted into the internal storage register. Sampling begins when \overline{BUSY} goes high.

To reduce the number of control pins, \overline{CS} can be tied low permanently. The R/\overline{C} pin then controls conversion and data reading exclusively. In the external clock mode, this configuration means that the ADS8519 clocks out data whenever R/\overline{C} is brought high and the external clock is active. In the internal clock mode, data are clocked out every convert cycle, regardless of the states of \overline{CS} and R/\overline{C} . The ADS8519 provides a TAG input for cascading multiple converters together.

READING DATA

The conversion result is available as soon as $BUSY$ returns to high; therefore, data always represent the conversion previously completed, even when it is read during a conversion. The ADS8519 outputs serial data in either straight binary or binary two's complement format. The SB/BTC pin controls the format. data are shifted out MSB first. The first conversion immediately following a power-up does not produce a valid conversion result.

Data can be clocked out with either the internally-generated clock or with an external clock. The EXT/\overline{INT} pin controls this function. If an external clock is used, the TAG input can be used to daisy-chain multiple ADS8519 data pins together.

INTERNAL DATACLK

In the internal clock mode, data for the previous conversion are clocked out during each conversion period. The internal data clock is synchronized to the internal conversion clock so that it does not interfere with the conversion process.

The DATACLK pin becomes an output when $\overline{\text{EXT}/\overline{\text{INT}}}$ is low. 16 clock pulses are generated at the beginning of each conversion after timing t_{d4} is satisfied (that is, previous conversion results can only be read during the current conversion). DATACLK returns to low when it is inactive. The 16 bits of serial data are shifted out of the DATA pin synchronous to this clock, with each bit available on a rising and then a falling edge. The DATA pin then returns to the state of the TAG pin input sensed at the start of transmission.

EXTERNAL DATACLK

The external clock mode offers several ways to retrieve conversion results. However, care must be taken to avoid corrupting the data because the external clock cannot be synchronized to the internal conversion clock.

When $\overline{\text{EXT}/\overline{\text{INT}}}$ is set high, the $\overline{\text{R}/\overline{\text{C}}}$ and $\overline{\text{CS}}$ signals control the read state. When the read state is initiated, the result from the previously completed conversion is shifted out of the DATA pin synchronous to the external clock that is connected to the DATACLK pin. Each bit is available on a falling and then a rising edge. The maximum external clock speed of 28.5MHz allows data to be shifted out quickly either at the beginning of conversion or the beginning of sampling.

There are several modes of operation available when using an external clock. It is recommended that the external clock run only while reading data. This mode is the discontinuous clock mode. Because the external clock is not synchronized to the internal clock that controls conversion, slight changes in the external clock can cause conflicts that can corrupt the conversion process. Specifications with a continuously running external clock cannot be ensured. It is especially important that the external clock does not run during the second half of the conversion cycle (approximately the time period specified by t_{d11} ; see the [Timing Requirements](#) table).

In the discontinuous clock mode, data can be read during conversion or during sampling, with or without a SYNC pulse. Data read during a conversion must meet the t_{d11} timing specification. Data read during sampling must be complete before starting a conversion.

Whether reading during sampling or during conversion, a SYNC pulse is generated whenever at least one rising edge of the external clock occurs while the device is not in the read state. In the *Discontinuous External Clock with SYNC* mode, a SYNC pulse follows the first rising edge after the read command. Data are shifted out after the SYNC pulse. The first rising clock edge after the read command generates a SYNC pulse. The SYNC pulse can be detected on the next falling edge and then the next rising edge. Successively, each bit can be read first on the falling edge and then on the next rising edge. Thus, 17 clock pulses after the read command are required to read on the falling edge; 18 clock pulses are necessary to read on the rising edge.

If the clock is entirely inactive when not in the read state, no SYNC pulse is generated. In this case, the first rising clock edge shifts out the MSB. The MSB can be read on the first falling edge or on the next rising edge. In this *Discontinuous External Clock with No SYNC* mode, 16 clocks are necessary to read the data on the falling edge and 17 clocks for reading on the rising edge. Data always represent the conversion already completed. [Table 1](#) summarizes the required DATACLK pulses.

Table 1. DATACLK Pulses

DESCRIPTION	DATACLK PULSES REQUIRED	
	WITH SYNC	WITHOUT SYNC
Read on falling edge of DATACLK	17	16
Read on rising edge of DATACLK	18	17

TAG FEATURE

The TAG feature allows the data from multiple ADS8519 converters to be read on a single serial line. The converters are cascaded together using the DATA pins as outputs and the TAG pins as inputs, as illustrated in Figure 28. The DATA pin of the last converter drives the processor serial data input. Data are then shifted through each converter, synchronous to the externally supplied data clock, onto the serial data line. The internal clock cannot be used for this configuration.

The preferred timing uses the discontinuous, external data clock during the sampling period. Data must be read during the sampling period because there is not sufficient time to read data from multiple converters during a conversion period without violating the t_{d11} constraint (see External DATACLK section). The sampling period must be sufficiently long to allow all data words to be read before starting a new conversion.

In Figure 28, note that a null bit separates the data word from each converter. The state of the DATA pin at the end of a read cycle reflects the state of the TAG pin at the start of the cycle. This condition is true in all read modes, including the internal clock mode. For example, when a single converter is used in the internal clock mode, the state of the TAG pin determines the state of the DATA pin after all 16 bits have shifted out. When multiple converters are cascaded together, this state forms the null bit that separates the words. Thus, with the TAG pin of the first converter grounded as shown in Figure 28, the null bit becomes a zero between each data word.

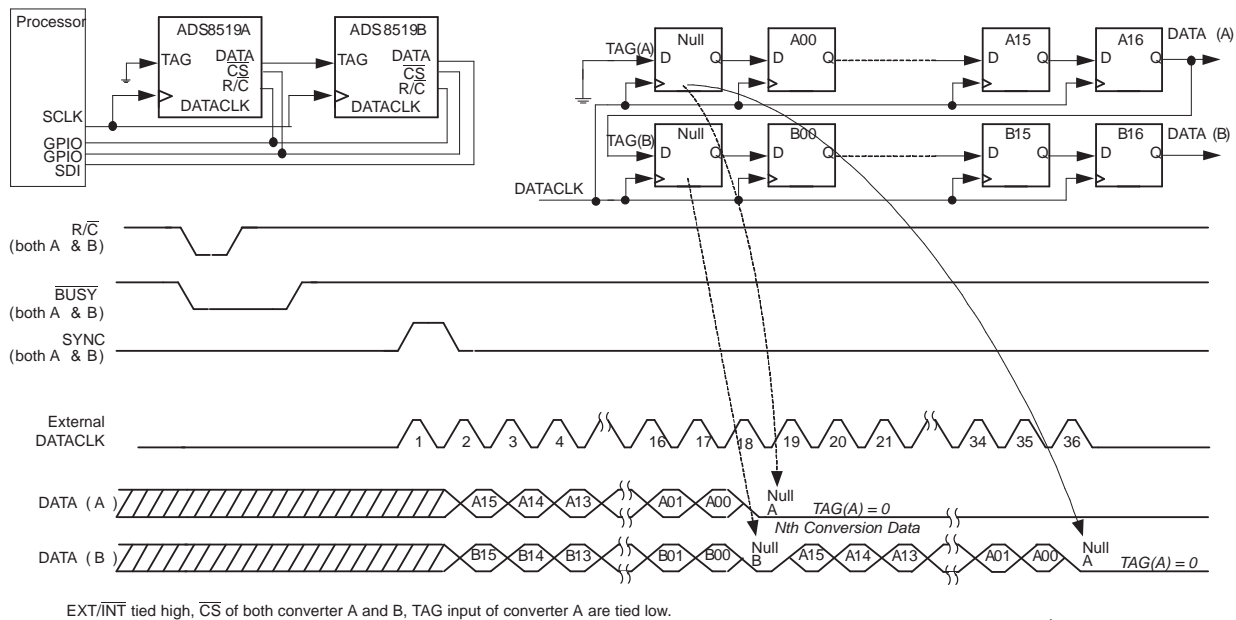

Figure 28. Timing of TAG Feature With Single Conversion (Using External DATACLK)

ANALOG INPUTS

The ADS8519 has three analog input ranges, as shown in Table 2. The offset specification is factory-calibrated with internal resistors. The gain specification is factory-calibrated with 0.1%, 0.25W, external resistors, as shown in Figure 29 and Figure 30. The external resistors can be omitted if a larger gain error is acceptable or if using software calibration. The hardware trim circuitry shown in Figure 29 and Figure 30 can reduce the error to zero.

Table 2. Input Range Connections
(see Figure 29 and Figure 30 for complete information)

ANALOG INPUT RANGE	CONNECT R _{1IN} TO	CONNECT R _{2IN} TO	CONNECT R _{3IN} TO	IMPEDANCE
±10V	V _{IN}	AGND	CAP	8.88kΩ
±10V	AGND	V _{IN}	CAP	8.88kΩ
±5V	V _{IN}	V _{IN}	CAP	6.08kΩ
0V to 8.192V	AGND	AGND	V _{IN}	5.95kΩ

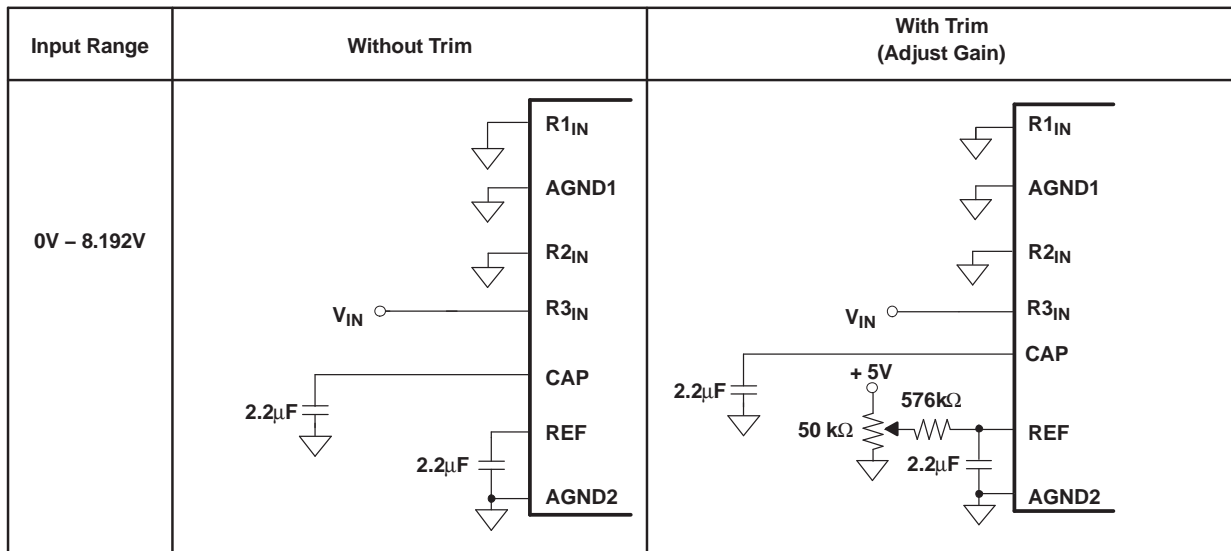

Figure 29. Offset/Gain Circuits for Unipolar Input Ranges

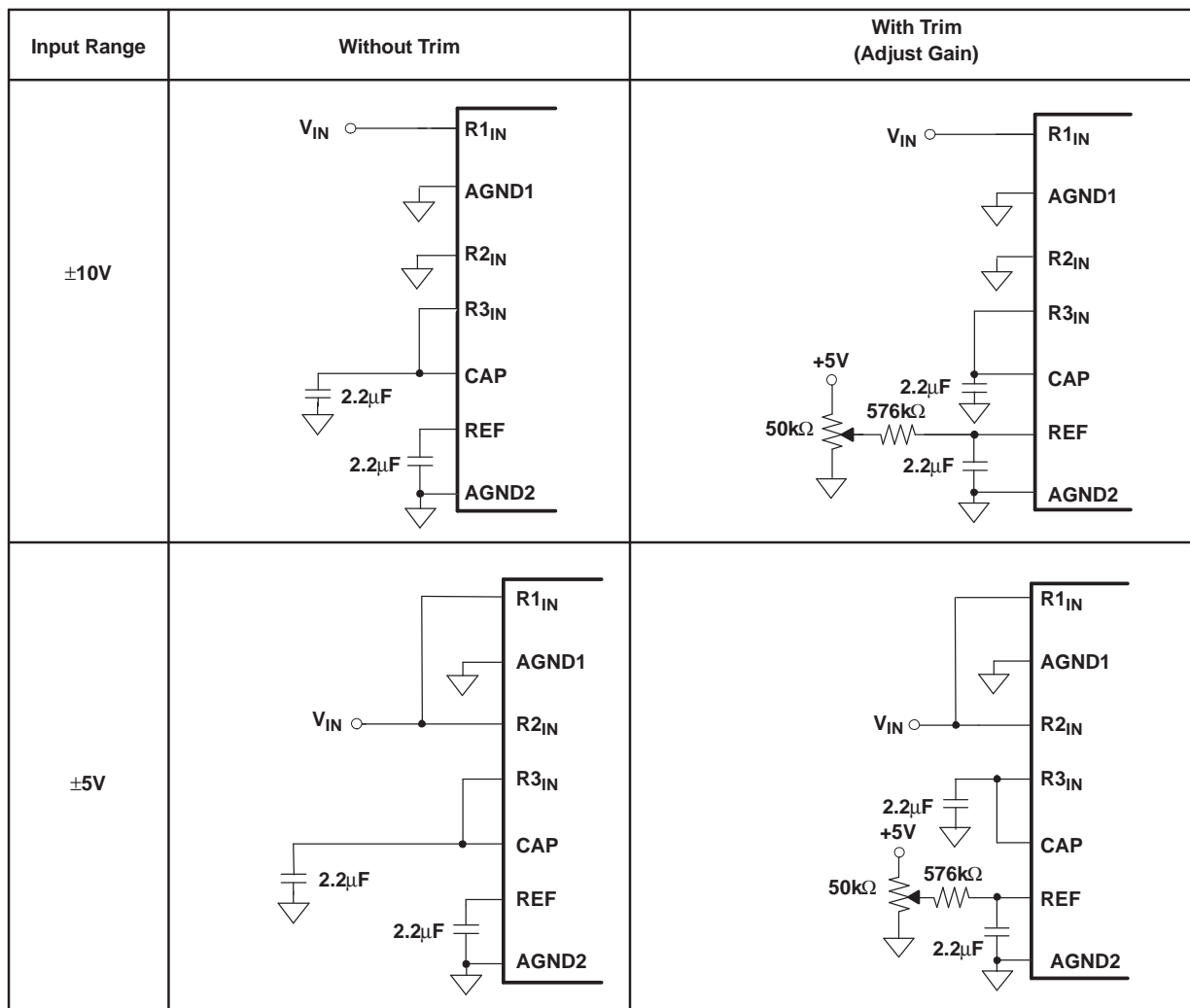

Figure 30. Offset/Gain Circuits for Bipolar Input Ranges

Analog input pins R1_{IN}, R2_{IN}, and R3_{IN} have $\pm 25V$ overvoltage protection. The input signal must be referenced to AGND1. This referencing minimizes the ground-loop problem typical to analog designs. The analog input should be driven by a low-impedance source. A typical driving circuit using the OPA627 or OPA132 is shown in Figure 30.

The ADS8519 can operate with its internal 4.096V reference or an external reference. An external reference connected to pin 7 (REF) bypasses the internal reference. The external reference must drive the 4kΩ resistor that separates pin 6 from the internal reference (see the illustration on page 1). The load varies with the difference between the internal and external reference voltages. The external reference voltage can vary from 3.9V to 4.2V. The internal reference is approximately 4.096V. The reference, whether internal or external, is buffered internally with the output on pin 6 (CAP).

The ADS8519 is factory-tested with 2.2µF capacitors connected to pin 6 (CAP) and pin 7 (REF). Each capacitor should be placed as close as possible to its pin. The capacitor on pin 7 band-limits the internal reference noise. A smaller capacitor can be used, but it may degrade SNR and SINAD. The capacitor on pin 6 stabilizes the reference buffer and provides switching charge to the CDAC during conversion. Capacitors smaller than 1µF may cause the buffer to become unstable and not hold sufficient charge for the CDAC. The parts are tested to specifications with 2.2µF, so larger capacitors are not necessary. The equivalent series resistance (ESR) of these compensation capacitors is also critical. Keep the total ESR under 3Ω. See the *Typical Characteristics* section concerning how ESR affects performance.

Neither the internal reference nor the buffer should be used to drive an external load. Such loading can degrade performance. Any load on the internal reference causes a voltage drop across the 4kΩ resistor and affects gain. The internal buffer is capable of driving ±2mA loads, but any load can cause perturbations of the reference at the CDAC, degrading performance. It should be pointed out that, unlike other devices with a similar input structure, the ADS8519 does not require a second high-speed amplifier used as a buffer to isolate the CAP pin from the signal-dependent current in the R3_{IN} pin, but can tolerate it if one does exist.

The external reference voltage can vary from 3.9V to 4.2V. The reference voltage determines the size of the least significant bit (LSB). The larger reference voltages produce a larger LSB, which can improve SNR. Smaller reference voltages can degrade SNR.

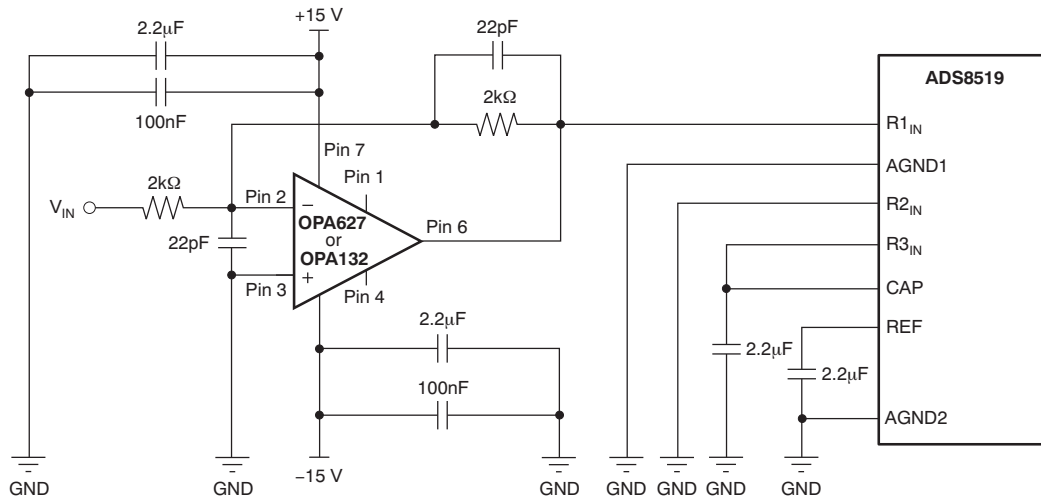

Figure 31. Typical Driving Circuitry (±10V, No Trim)

Table 3. Control Truth Table

SPECIFIC FUNCTION	\overline{CS}	R/C	\overline{BUSY}	EXT/ \overline{INT}	DATACLK	PWRD	SB/ \overline{BTC}	OPERATION
Initiate conversion and output data using internal clock	1 > 0	0	1	0	Output	0	x	Initiates conversion <i>n</i> . Data from conversion <i>n</i> - 1 clocked out on DATA synchronized to 16 clock pulses output on DATACLK.
	0	1 > 0	1	0	Output	0	x	
Initiate conversion and output data using external clock	1 > 0	0	1	1	Input	0	x	Initiates conversion <i>n</i> .
	0	1 > 0	1	1	Input	0	x	Initiates conversion <i>n</i> .
	1 > 0	1	1	1	Input	x	x	Outputs data with or without SYNC pulse. See the Reading Data section.
	1 > 0	1	0	1	Input	0	x	Outputs data with or without SYNC pulse. See Reading Data section.
	0	0 > 1	0	1	Input	0	x	Outputs data with or without SYNC pulse.
No actions	0	0	0 > 1	x	x	0	x	This is an acceptable condition.
Power down	x	x	x	x	x	0	x	Analog circuitry powered. Conversion can proceed..
	x	x	x	x	x	1	x	Analog circuitry disabled. Data from previous conversion maintained in output registers.
Selecting output format	x	x	x	x	x	x	0	Serial data are output in binary twos complement format.
	x	x	x	x	x	x	1	Serial data are output in straight binary format.

Table 4. Output Codes and Ideal Input Voltages

DESCRIPTION	ANALOG INPUT RANGE			DIGITAL OUTPUT			
	±10V	±5V	0V to 8.192V	BINARY TWOS COMPLEMENT (SB/BTC LOW)		STRAIGHT BINARY (SB/BTC HIGH)	
Least significant bit (LSB)	305µV	153µV	125µV	BINARY CODE	HEX CODE	BINARY CODE	HEX CODE
+Full-scale (FS - 1LSB)	9.99695V	4.99847V	8.191875V	0111 1111 1111 1111	7FFF	1111 1111 1111 1111	FFFF
Midscale	0V	0V	4.096V	0000 0000 0000 0000	0000	1000 0000 0000 0000	8000
One LSB below midscale	-305µV	153µV	4.095975V	1111 1111 1111 1111	FFFF	0111 1111 1111 1111	7FFF
-Full scale	-10V	-5V	0V	1000 0000 0000 0000	8000	0000 0000 0000 0000	0000

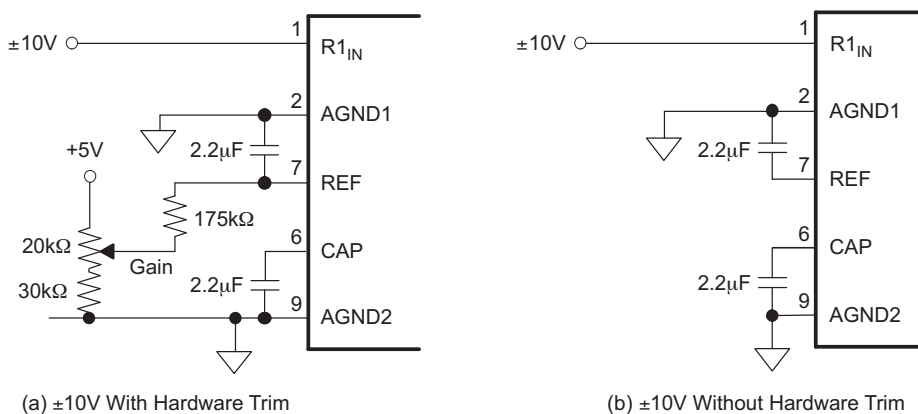

Figure 32. Gain Adjust Trim

REVISION HISTORY

NOTE: Page numbers for previous revisions may differ from page numbers in the current version.

Changes from Revision C (June, 2009) to Revision D	Page
• Changed input/output description for SB/BTC pin (pin 12)	6

Changes from Revision B (October, 2008) to Revision C	Page
• Changed external reference voltage range min value from 2.5V to 3.9V and max value from 4.1V to 4.2V	3
• Corrected pin names and numbers in paragraphs discussing internal and external reference operation and factory testing of device with 2.2μF capacitors.	19

PACKAGING INFORMATION

Orderable Device	Status (1)	Package Type	Package Drawing	Pins	Package Qty	Eco Plan (2)	Lead/Ball Finish (6)	MSL Peak Temp (3)	Op Temp (°C)	Device Marking (4/5)	Samples
ADS8519IBDB	ACTIVE	SSOP	DB	28	50	Green (RoHS & no Sb/Br)	CU NIPDAU	Level-2-260C-1 YEAR	-40 to 85	ADS8519I B	Samples
ADS8519IBDBG4	ACTIVE	SSOP	DB	28	50	Green (RoHS & no Sb/Br)	CU NIPDAU	Level-2-260C-1 YEAR	-40 to 85	ADS8519I B	Samples
ADS8519IBDBR	ACTIVE	SSOP	DB	28	2000	Green (RoHS & no Sb/Br)	CU NIPDAU	Level-2-260C-1 YEAR	-40 to 85	ADS8519I B	Samples
ADS8519IDB	ACTIVE	SSOP	DB	28	50	Green (RoHS & no Sb/Br)	CU NIPDAU	Level-2-260C-1 YEAR	-40 to 85	ADS8519I	Samples
ADS8519IDBR	ACTIVE	SSOP	DB	28	2000	Green (RoHS & no Sb/Br)	CU NIPDAU	Level-2-260C-1 YEAR	-40 to 85	ADS8519I	Samples

(1) The marketing status values are defined as follows:

ACTIVE: Product device recommended for new designs.

LIFEBUY: TI has announced that the device will be discontinued, and a lifetime-buy period is in effect.

NRND: Not recommended for new designs. Device is in production to support existing customers, but TI does not recommend using this part in a new design.

PREVIEW: Device has been announced but is not in production. Samples may or may not be available.

OBsolete: TI has discontinued the production of the device.

(2) Eco Plan - The planned eco-friendly classification: Pb-Free (RoHS), Pb-Free (RoHS Exempt), or Green (RoHS & no Sb/Br) - please check <http://www.ti.com/productcontent> for the latest availability information and additional product content details.

TBD: The Pb-Free/Green conversion plan has not been defined.

Pb-Free (RoHS): TI's terms "Lead-Free" or "Pb-Free" mean semiconductor products that are compatible with the current RoHS requirements for all 6 substances, including the requirement that lead not exceed 0.1% by weight in homogeneous materials. Where designed to be soldered at high temperatures, TI Pb-Free products are suitable for use in specified lead-free processes.

Pb-Free (RoHS Exempt): This component has a RoHS exemption for either 1) lead-based flip-chip solder bumps used between the die and package, or 2) lead-based die adhesive used between the die and leadframe. The component is otherwise considered Pb-Free (RoHS compatible) as defined above.

Green (RoHS & no Sb/Br): TI defines "Green" to mean Pb-Free (RoHS compatible), and free of Bromine (Br) and Antimony (Sb) based flame retardants (Br or Sb do not exceed 0.1% by weight in homogeneous material)

(3) MSL, Peak Temp. - The Moisture Sensitivity Level rating according to the JEDEC industry standard classifications, and peak solder temperature.

(4) There may be additional marking, which relates to the logo, the lot trace code information, or the environmental category on the device.

(5) Multiple Device Markings will be inside parentheses. Only one Device Marking contained in parentheses and separated by a "-" will appear on a device. If a line is indented then it is a continuation of the previous line and the two combined represent the entire Device Marking for that device.



⁽⁶⁾ Lead/Ball Finish - Orderable Devices may have multiple material finish options. Finish options are separated by a vertical ruled line. Lead/Ball Finish values may wrap to two lines if the finish value exceeds the maximum column width.

Important Information and Disclaimer: The information provided on this page represents TI's knowledge and belief as of the date that it is provided. TI bases its knowledge and belief on information provided by third parties, and makes no representation or warranty as to the accuracy of such information. Efforts are underway to better integrate information from third parties. TI has taken and continues to take reasonable steps to provide representative and accurate information but may not have conducted destructive testing or chemical analysis on incoming materials and chemicals. TI and TI suppliers consider certain information to be proprietary, and thus CAS numbers and other limited information may not be available for release.

In no event shall TI's liability arising out of such information exceed the total purchase price of the TI part(s) at issue in this document sold by TI to Customer on an annual basis.

TAPE AND REEL INFORMATION

REEL DIMENSIONS

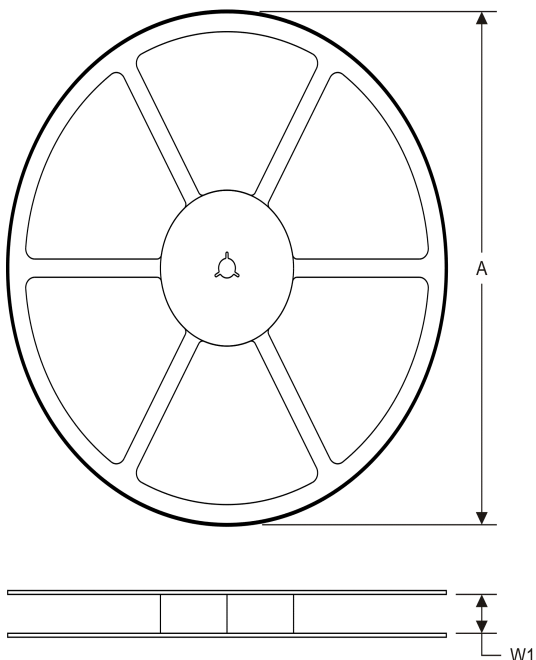

TAPE DIMENSIONS

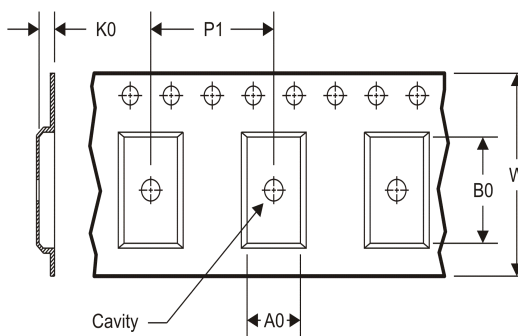

A0	Dimension designed to accommodate the component width
B0	Dimension designed to accommodate the component length
K0	Dimension designed to accommodate the component thickness
W	Overall width of the carrier tape
P1	Pitch between successive cavity centers

TAPE AND REEL INFORMATION

*All dimensions are nominal

Device	Package Type	Package Drawing	Pins	SPQ	Reel Diameter (mm)	Reel Width W1 (mm)	A0 (mm)	B0 (mm)	K0 (mm)	P1 (mm)	W (mm)	Pin1 Quadrant
ADS8519IBDBR	SSOP	DB	28	2000	330.0	16.4	8.1	10.4	2.5	12.0	16.0	Q1
ADS8519IDBR	SSOP	DB	28	2000	330.0	16.4	8.1	10.4	2.5	12.0	16.0	Q1

TAPE AND REEL BOX DIMENSIONS

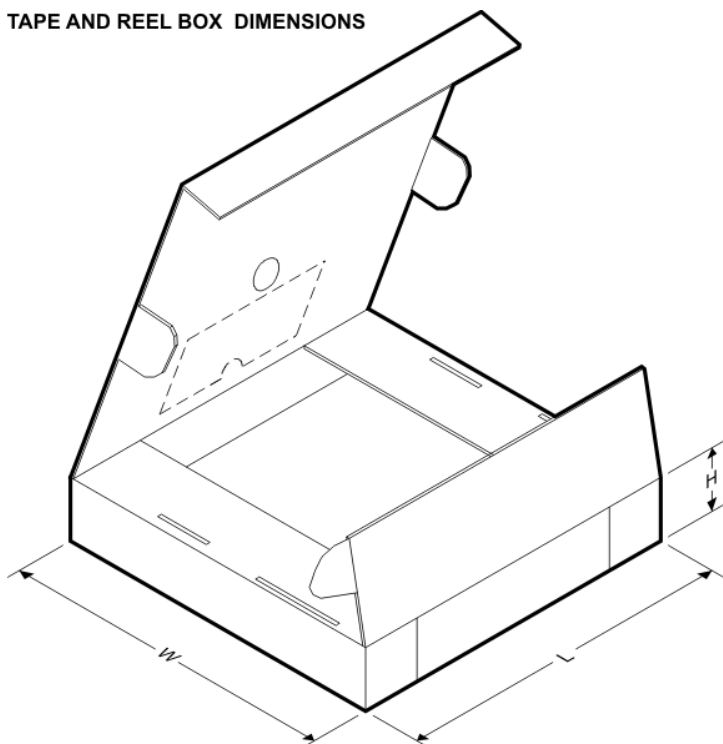

*All dimensions are nominal

Device	Package Type	Package Drawing	Pins	SPQ	Length (mm)	Width (mm)	Height (mm)
ADS8519IBDBR	SSOP	DB	28	2000	367.0	367.0	38.0
ADS8519IDBR	SSOP	DB	28	2000	367.0	367.0	38.0

MSS0002E - JANUARY 1995 - REVISED DECEMBER 2001

DB (R-PDSO-G)**

PLASTIC SMALL-OUTLINE

28 PINS SHOWN

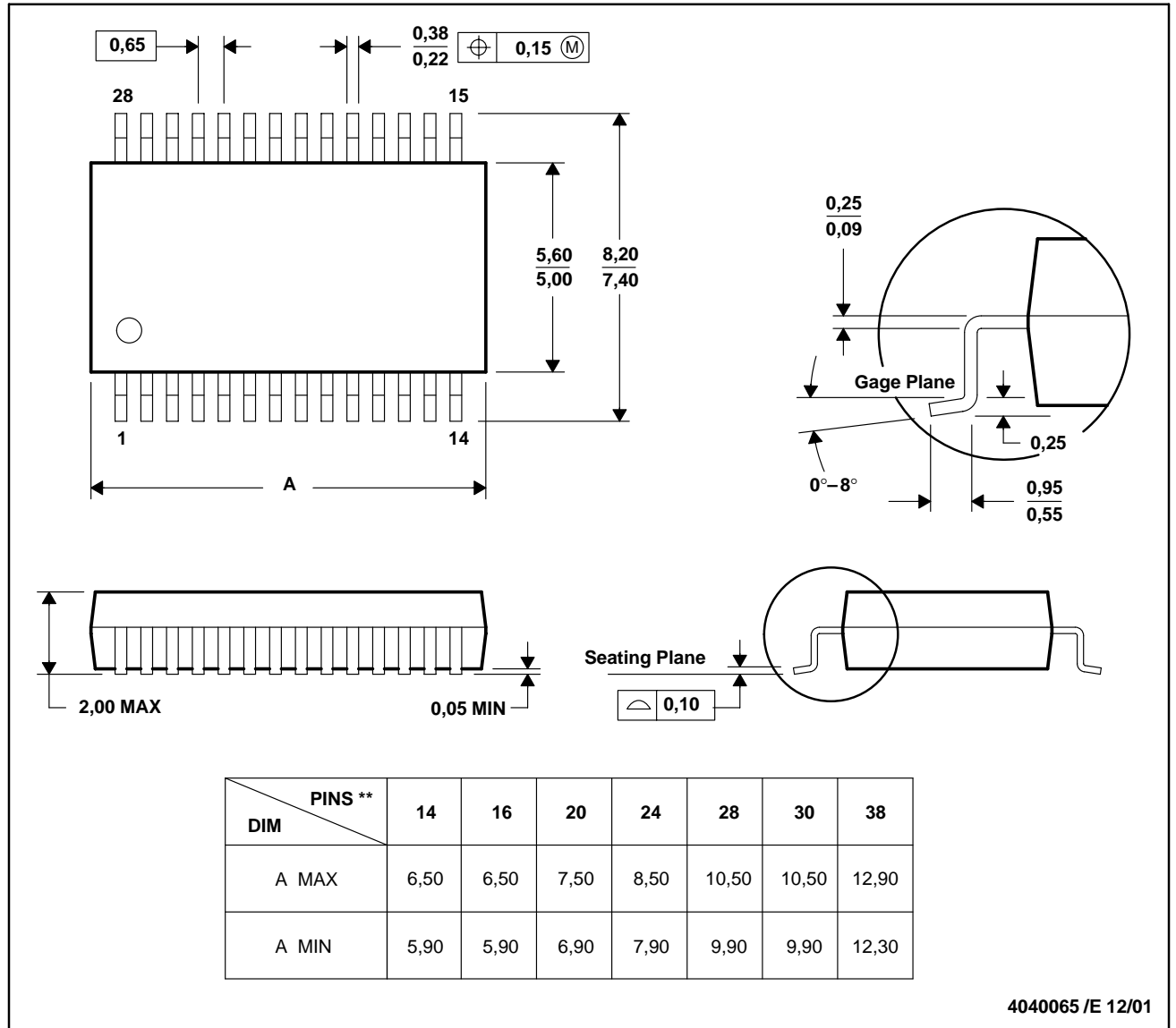

4040065 / E 12/01

- NOTES: A. All linear dimensions are in millimeters.
 B. This drawing is subject to change without notice.
 C. Body dimensions do not include mold flash or protrusion not to exceed 0,15.
 D. Falls within JEDEC MO-150

IMPORTANT NOTICE

Texas Instruments Incorporated and its subsidiaries (TI) reserve the right to make corrections, enhancements, improvements and other changes to its semiconductor products and services per JESD46, latest issue, and to discontinue any product or service per JESD48, latest issue. Buyers should obtain the latest relevant information before placing orders and should verify that such information is current and complete. All semiconductor products (also referred to herein as "components") are sold subject to TI's terms and conditions of sale supplied at the time of order acknowledgment.

TI warrants performance of its components to the specifications applicable at the time of sale, in accordance with the warranty in TI's terms and conditions of sale of semiconductor products. Testing and other quality control techniques are used to the extent TI deems necessary to support this warranty. Except where mandated by applicable law, testing of all parameters of each component is not necessarily performed.

TI assumes no liability for applications assistance or the design of Buyers' products. Buyers are responsible for their products and applications using TI components. To minimize the risks associated with Buyers' products and applications, Buyers should provide adequate design and operating safeguards.

TI does not warrant or represent that any license, either express or implied, is granted under any patent right, copyright, mask work right, or other intellectual property right relating to any combination, machine, or process in which TI components or services are used. Information published by TI regarding third-party products or services does not constitute a license to use such products or services or a warranty or endorsement thereof. Use of such information may require a license from a third party under the patents or other intellectual property of the third party, or a license from TI under the patents or other intellectual property of TI.

Reproduction of significant portions of TI information in TI data books or data sheets is permissible only if reproduction is without alteration and is accompanied by all associated warranties, conditions, limitations, and notices. TI is not responsible or liable for such altered documentation. Information of third parties may be subject to additional restrictions.

Resale of TI components or services with statements different from or beyond the parameters stated by TI for that component or service voids all express and any implied warranties for the associated TI component or service and is an unfair and deceptive business practice. TI is not responsible or liable for any such statements.

Buyer acknowledges and agrees that it is solely responsible for compliance with all legal, regulatory and safety-related requirements concerning its products, and any use of TI components in its applications, notwithstanding any applications-related information or support that may be provided by TI. Buyer represents and agrees that it has all the necessary expertise to create and implement safeguards which anticipate dangerous consequences of failures, monitor failures and their consequences, lessen the likelihood of failures that might cause harm and take appropriate remedial actions. Buyer will fully indemnify TI and its representatives against any damages arising out of the use of any TI components in safety-critical applications.

In some cases, TI components may be promoted specifically to facilitate safety-related applications. With such components, TI's goal is to help enable customers to design and create their own end-product solutions that meet applicable functional safety standards and requirements. Nonetheless, such components are subject to these terms.

No TI components are authorized for use in FDA Class III (or similar life-critical medical equipment) unless authorized officers of the parties have executed a special agreement specifically governing such use.

Only those TI components which TI has specifically designated as military grade or "enhanced plastic" are designed and intended for use in military/aerospace applications or environments. Buyer acknowledges and agrees that any military or aerospace use of TI components which have **not** been so designated is solely at the Buyer's risk, and that Buyer is solely responsible for compliance with all legal and regulatory requirements in connection with such use.

TI has specifically designated certain components as meeting ISO/TS16949 requirements, mainly for automotive use. In any case of use of non-designated products, TI will not be responsible for any failure to meet ISO/TS16949.

Products

Audio	www.ti.com/audio
Amplifiers	amplifier.ti.com
Data Converters	dataconverter.ti.com
DLP® Products	www.dlp.com
DSP	dsp.ti.com
Clocks and Timers	www.ti.com/clocks
Interface	interface.ti.com
Logic	logic.ti.com
Power Mgmt	power.ti.com
Microcontrollers	microcontroller.ti.com
RFID	www.ti-rfid.com
OMAP Applications Processors	www.ti.com/omap
Wireless Connectivity	www.ti.com/wirelessconnectivity

Applications

Automotive and Transportation	www.ti.com/automotive
Communications and Telecom	www.ti.com/communications
Computers and Peripherals	www.ti.com/computers
Consumer Electronics	www.ti.com/consumer-apps
Energy and Lighting	www.ti.com/energy
Industrial	www.ti.com/industrial
Medical	www.ti.com/medical
Security	www.ti.com/security
Space, Avionics and Defense	www.ti.com/space-avionics-defense
Video and Imaging	www.ti.com/video

TI E2E Community

e2e.ti.com