



Distributor of AVX Corporation: Excellent Integrated System Limited

Datasheet of CX2520SB40000H0DZF08 - Crystal 40.0000MHz 8ppm 12pF 35 Ohm -10°C - 85°C Surface Mount 4-SMD, No Lead (DFN, LCC)

Contact us: sales@integrated-circuit.com Website: www.integrated-circuit.com

Excellent Integrated System Limited

Stocking Distributor

Click to view price, real time Inventory, Delivery & Lifecycle Information:

[AVX Corporation](#)

[CX2520SB40000H0DZF08](#)

For any questions, you can email us directly:

sales@integrated-circuit.com

No.	K1101-07042-311	1(11)
-----	-----------------	-------

Date: 2007/ 2/ 8

Messrs: Atheros

Preliminary Specification

Customer part number	-
Customer specification Number	-
Product	Quartz Crystal
Model	CX2520SB
Frequency	40000kHz
Part Number	CX2520SB40000H0DZF08

Pb Free, RoHS Compliant

[STAMP]

Sales office
 KYOCERA Corporation
 (Electronic Components Sales Division)
 Head Office 6 Takeda Tobadono-cho, Fushimi-ku,
 Kyoto 612-8501 Japan
 TEL 075-604-3500
 FAX 075-604-3501

Production
 KYOCERA KINSEKI Corporation
 (Crystal Unit Sales Promotion Division)
 1-8-1, Izumi-honcho, Komae-Shi,
 Tokyo 201-8648 Japan
 TEL 03-5497-3111
 FAX 03-5497-3209

Design KYOCERA KINSEKI Yamagata Co. Crystal Units Division	Issued by 	Approved by
---	----------------------	------------------------



No.	K1101-07042-311	2(11)
-----	-----------------	-------

Date: 2007/ 2/ 8

Change History

Rev	DESCRIPTION	DATE	DRAWN	CHECKED	APPROVED
0	Preliminary spec release	2007/ 2/ 8	<i>T. M. Tack</i>		<i>[Signature]</i>

No.	K1101-07042-311	3(11)
-----	-----------------	-------

Date: 2007/ 2/ 8

1. APPLICATION

This specification sheet is applied to quartz crystal "CX2520SB".

2. PART NUMBER

CX2520SB40000H0DZF08

3. RATINGS

Items	SYMB.	Rating	Unit	Remarks
Operating Temperature	Topr	-10~+85	deg. C	
Storage Temperature range	Tstg	-40~+85	deg. C	

4. CHARACTERISTICS

ELECTRICAL CHARACTERISTICS

Items	Electrical Specification					Test Condition	Remarks
	SYMB	Min	Typ.	Max	Unit		
Mode of Vibration		Fundamental					
Nominal Frequency	F0		40		MHz		
Nominal Temperature	T _{NOM}		25		deg. C		
Load Capacitance	CL		12.0		pF		
Frequency Tolerance	df/F	-8.0		8.0	PPM	25±5°C Network Analyzer E5100A 200 μA	
Frequency Temperature characteristics	df/F	-10.0		10.0		-10~+85°C	
Frequency Ageing Rate		-1.0		1.0		1year	25±5°C
Equivalent Series Resistance	ESR			35	Ohms	Network Analyzer E5100A 200 μA	
Drive Level	Pd	0.0014		0.1	mW		
Insulation Resistance	IR	500			M ohms	100V(DC)	

No.	K1101-07042-311	4(11)
-----	-----------------	-------

Date: 2007/ 2/ 8

5. APPEARANCES, PHYSICAL DIMENSION
OUTLINE DIMENSION (not to scale)

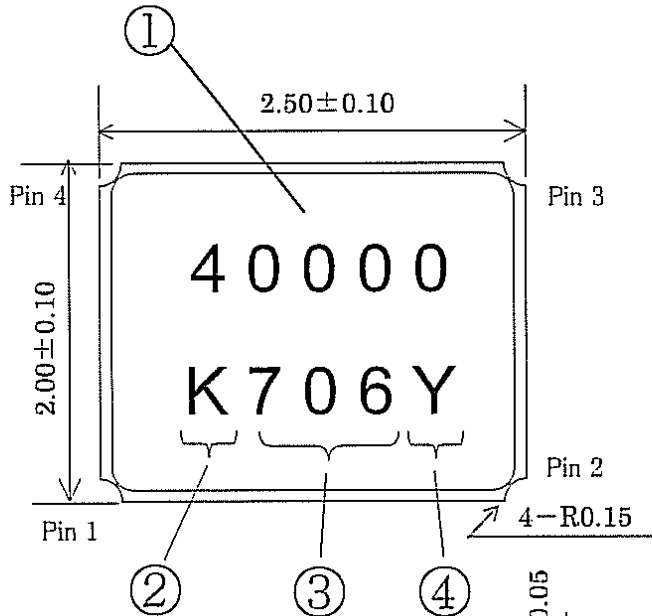

**CONNECTION
(TOP VIEW)**

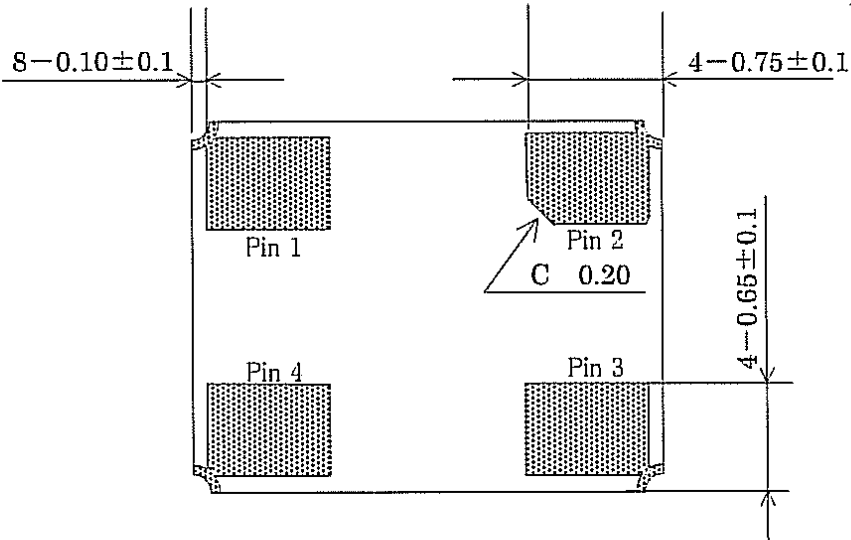
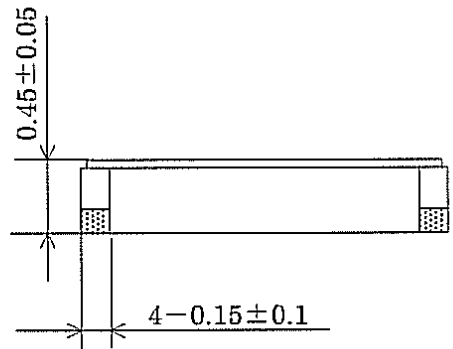
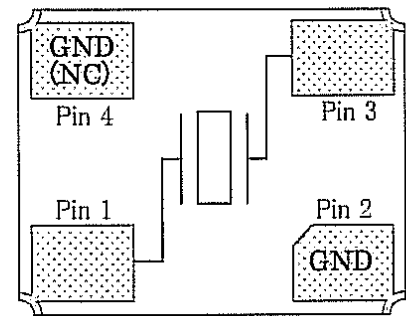

UNIT : mm

MARKING

- ① Nominal Frequency Move the number of maximum indication beams of the frequency to five digits, and omit less than kHz.
- ② Identification
- ③ Date Code Year...LAST 1 DIGIT of YEAR AND WEEK ※For details to P11
(Ex) February 8, 2007 → 706
- ④ Manufacturing Location

Y...Yamagata
 Z...Shiga Yohkaich

No.	K1101-07042-311	5(11)
-----	-----------------	-------

Date: 2007/ 2/ 8

6. RECOMMENDED LAND PATTERN (not to scale)

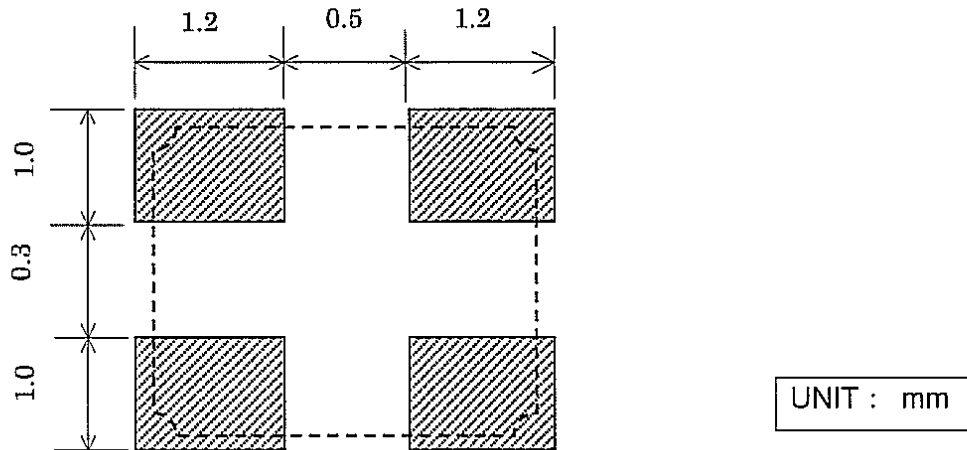

7. Quality Assurance

Location

Kyocera Kinseki Yamagata Corporation ... Kyocera Kinseki Yamagata

Quality Assurance Division

Kyocera Kinseki Corporation Shiga Yohkaichi Plant ... Kyocera Kinseki

Quality Assurance Division

Quality guarantee

When the failure by the responsibility of our company occurs clearly after delivery within 1 year, a substitute article etc. is appropriated gratuitously and this is guaranteed. However, when passing 1 year after delivery, there is a case where I am allowed to consider as onerous repair after both consultation.

No.	K1101-07042-311	6(11)
-----	-----------------	-------

Date: 2007/ 2/ 8

8.TAPING&REEL 梱包補助材

8-1.Dimensions (寸法図)

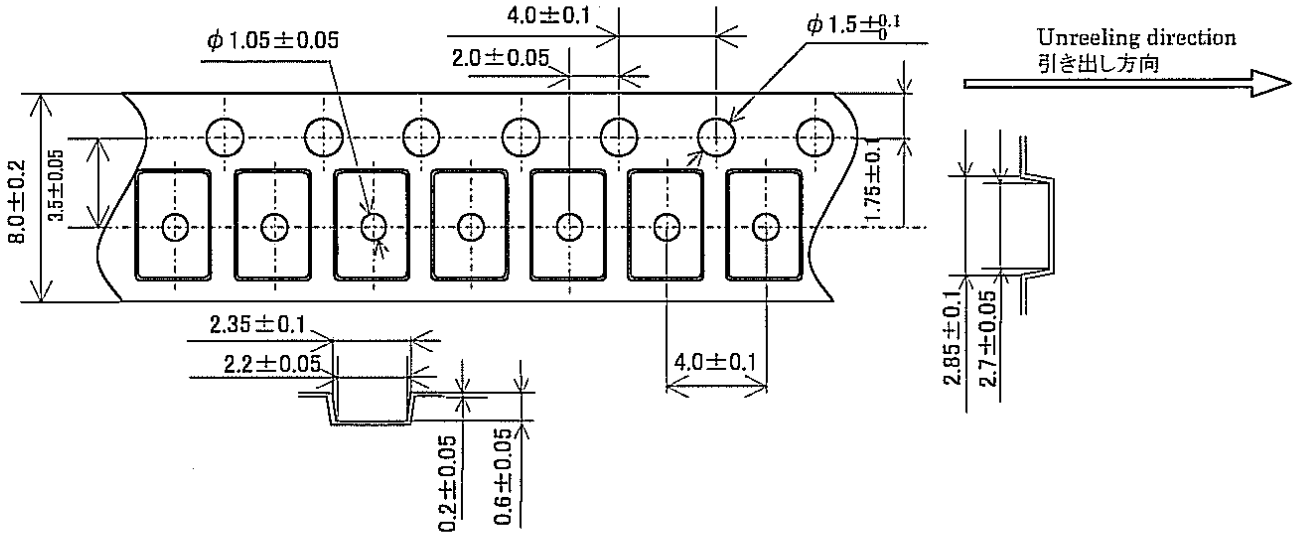

8-2.Leader and trailer tape (リーダー部テープ部及び終末端部テープ)

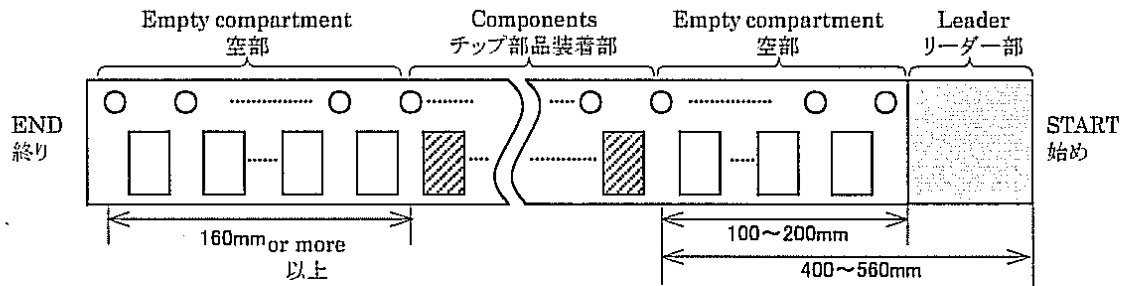

8-3.Direction (The direction shall be seen from the top cover tape side)

テーピング方向
 (トップカバーテープ側から見る。)

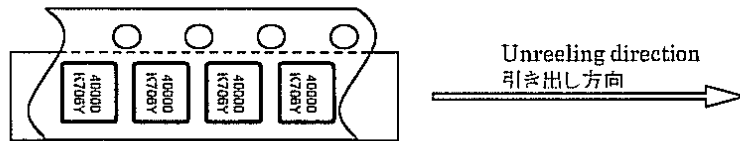

8-4.Specification (記事)

- Material of the carrier tape shall be EC-AP, Polycarbonate, A-PET or PS(all ESD).
 {装着テープの材質は、EC-AP、ポリカーボネイト、A-PET、PS (全て静電対策品) の何れかとする。}
- Material of the seal tape shall be polyester(ESD).{ シールテープの材質はポリエステルとする。(静電対策品) }
- The seal tape shall not cover the sprocket holes. And not protrude from the carrier tape.
 {シールテープは送り穴をふさいだり、装着テープからはみ出していないこと。}
- Tensile strength of the tape : 10N or more. {テープの引張り強度は10N 以上}
- The R of the corner without designation is 0.2RMAX. {指定無きコーナーのR は0.2RMAX}
- Disalignment between centers of the cavity and sprocket hole shall be 0.05mm or less. {角穴の中心と送り穴の中心とのずれは、0.05mm 以下とする。}
- Cumulative pitch tolerance of "P₀" shall be ±0.2mm at 10 pitches. {"P₀"の累積ピッチ許容差は、10 ピッチで±0.2mm とする。}
- Keep direction of a printing at tape inside. {エンボステープ内における印字は上図の方向とする。}
- Peeling force of the seal tape: 0.1 to 0.7N. {シールテープ剥離強度 0.1~0.7N}
- The component can fall headlong naturally from taping in she environment, such dry conditions, when this components were transferred to, cover was removed and the component was moved upside down.
 カバーテープを外しテープを逆さにしたとき、輸送後及び乾燥等の環境下でも自重で部品が落下できる。

160° ~180°
 Cover tape (カバーテープ)

No.	K1101-07042-311	7(11)
-----	-----------------	-------

Date: 2007/ 2/ 8

Reel specifications リール

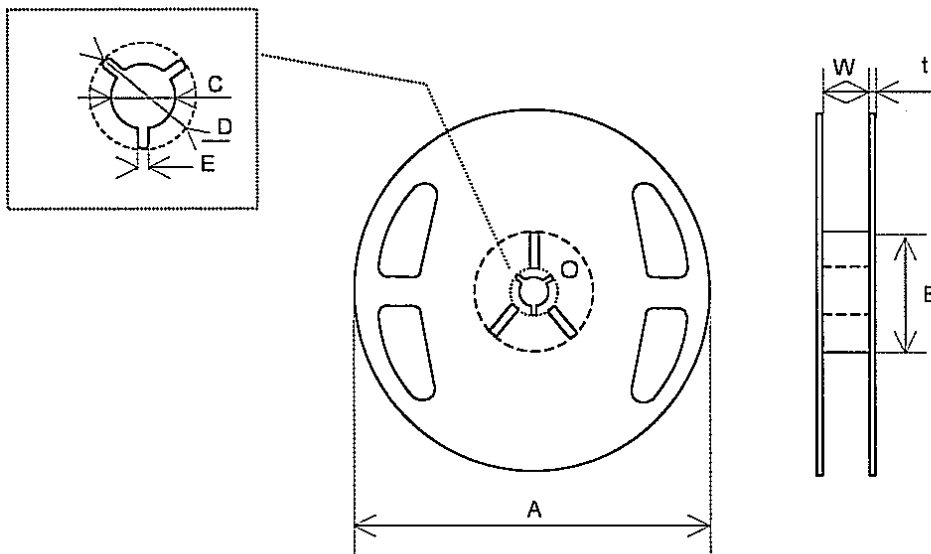

In the case of $\Phi 180$ Reel (1000 or 3000 pcs)

Symbol	A	B	C	D
Dimension	$\phi 180 +0/-3$	$\phi 60 +1/-0$	$\phi 13 \pm 0.2$	$\phi 21 \pm 0.8$
Symbol	E	W	t	
Dimension	2.0 ± 0.5	9 ± 1	2.0 ± 0.5	

(Unit : mm)

In the case of $\Phi 330$ Reel (1000 or 3000 or 5000 pcs)

Symbol	A	B	C	D
Dimension	$\phi 330 \pm 0.2$	$\phi 100 \pm 1.0$	$\phi 13 \pm 0.2$	$\phi 21 \pm 0.8$
Symbol	E	W	t	
Dimension	2.0 ± 0.5	13.5 ± 0.5	2.2 ± 0.1	

(Unit : mm)

No.	K1101-07042-311	8(11)
-----	-----------------	-------

Date: 2007/ 2/ 8

9. Environmental requirements

After following test, frequency shall not change more than $\pm 20 \times 10^{-6}$
 And Cl, $\pm 20\%$ or 5Ω of large value.

- | | |
|-----------------------------|---|
| 9.1 Resistance to Shock | <p>Test condition</p> <p>Natural dropped from height 100cm onto hard wood board in 3 times</p> |
| 9.2 Resistance to Vibration | <p>Test condition</p> <p>frequency : 10—55 — 10 Hz</p> <p>Amplitude : 1.5mm</p> <p>Cycle time : 15 minutes</p> <p>Direction : X,Y,Z (3direction),2 h each.</p> |
| 9.3 Resistance to Heat | <p>Test condition</p> <p>The quartz crystal unit shall be stored at a temperature of $+85 \pm 2^\circ\text{C}$ for 500 h.</p> <p>Then it shall be subjected to standard atmospheric conditions for 1 h ,after whichi measurement shall be made.</p> |
| 9.4 Resistance to Cold | <p>Test condition</p> <p>The quartz crystal unit shall be stored at a temperature of $-40 \pm 2^\circ\text{C}$ for 500 h.</p> <p>Then it shall be subjected to standard atmospheric conditions for 1 h ,after whichi measurement shall be made.</p> |
| 9.5 Thermal Shock | <p>Test condition</p> <p>The quartz crystal unit shall be subjected to 500 succesive change of temperature cycles , each as shown in table below, Then it shall be subjected to standard atmospheric conditions for 1h, after which measurements shall be made.</p> <p>Cycle : $-40 \pm 2^\circ\text{C}$ (30min.) \sim $-25 \pm 2^\circ\text{C}$ (5min.)
 \sim $+85 \pm 2^\circ\text{C}$ (30min.) \sim $-25 \pm 2^\circ\text{C}$ (5min.)</p> |

No.	K1101-07042-311	9(11)
-----	-----------------	-------

Date: 2007/ 2/ 8

9.6 Resistance to Moisture

Test condition

The quartz crystal unit shall be stored at a temperature of $60 \pm 2^\circ\text{C}$ with relative humidity of 90% to 95% for 240 h. Then it shall be subjected to standard atmospheric conditions for 1h, after which measurements shall be made

9.7 Soldering condition

1.) Material of solder

Kind ... lead free solder paste
 Melting point ... $220 \pm 5^\circ\text{C}$

2.) Temp.profile of reflow soldering system

	Temp [$^\circ\text{C}$]	Time[sec]
Peak	260 ± 5	10 (max.)
Preheating	180 (typ.)	100 (typ.)
Total	—	200 (max.)

Reflow times : 2times

Frequency shift : $\pm 2\text{ppm}$

Temp. profile of reflow

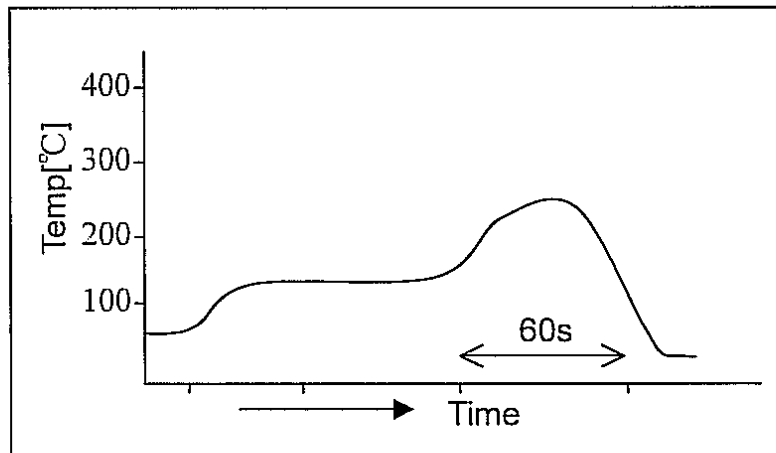

9.8 Intensity for bending in circuit board

Solder this product in center of the circuit board of $40\text{mm} \times 100\text{mm}$, and add the deflection of 3mm as the bottom figure.

Test board : $t=1.6\text{mm}$

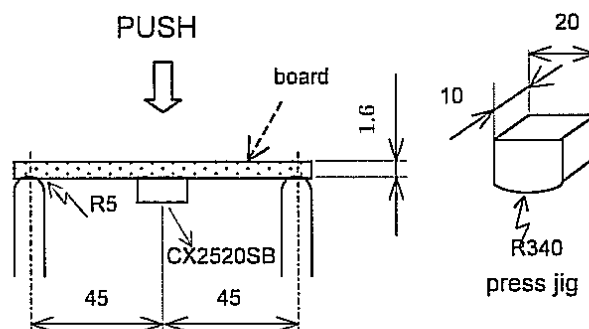

UNIT : mm

No.	K1101-07042-311	10(11)
-----	-----------------	--------

Date: 2007/ 2/ 8

10.Cautions for use

(1) Automatic mounting machine use

Please use after affirmation that select the mounting machine model with a shock small if possible in the case of use of an automatic mounting machine, and it does not have breakage. There is a risk of a crystal oscillating child's breakage occurring and not functioning normally by too much shock etc.

(2) Conformity of a circuit

In case of use of an oscillation circuit, please insert in a crystal oscillating child in series resistance 5 time as many as the standard value of equivalent in-series resistance, and confirm oscillating. Please remove resistance which inserted after the notes above-mentioned examination in the crystal oscillating child in series, and use it.

11.Storage conditions

Storage at prolonged high temperature or low temperature and the storage by high humidity cause degradation of frequency accuracy, and degradation of soldering nature. Storage is performed at the temperature of 18-30 degrees C, and the humidity of 20-70 Percent in the state of packing, and a term is 6 months.

12.Others

When any questions and opinions are in the written matter of these delivery specifications, I will ask connection of you from the our company issue day within 45 days. In a connection no case, a written matter is consented to it and employed within a term.

