

## **Excellent Integrated System Limited**

Stocking Distributor

Click to view price, real time Inventory, Delivery & Lifecycle Information:

[Vishay/Siliconix](#)  
[DG469EQ-T1-E3](#)

For any questions, you can email us directly:

[sales@integrated-circuit.com](mailto:sales@integrated-circuit.com)



## DG469, DG470

Vishay Siliconix

# High Voltage, Single and Dual Supply SPDT Analog Switch with Enable Pin

### DESCRIPTION

The DG469, DG470 are high voltage SPDT switches, with a typical on resistance of 3.6  $\Omega$  and typical flatness of 0.4  $\Omega$ . The DG469, DG470 are identical, except the DG470 provides an enable input. When the enable input is activated, both sides of the switch are in a high impedance mode (Off), maintaining a "Safe State" at power up. This function can also be used as a quick "disconnect" in the event of a fault condition. For audio switching, the enable pin provides a mute function. These are high voltage switches that are fully specified with dual supplies at  $\pm 4.5$  V and  $\pm 15$  V and a single supply of 12 V over an operating temperature range from -40  $^{\circ}$ C to +125  $^{\circ}$ C. Fast switching speeds coupled with high signal bandwidth makes these parts suitable for video switching applications. All digital inputs have 0.8 V and 2.4 V logic thresholds ensuring low voltage TTL/CMOS compatibility. Each switch conducts equally well in both directions when on and can handle an input signal range that extends to the supply voltage rails. They exhibit break-before-make switching action to prevent momentary shorting when switching between channels. The DG469, DG470 are offered in a MSOP 8 and SOIC 8 package.

### FEATURES

- Low on resistance (3.6  $\Omega$  typical)
- On resistance flatness (0.4  $\Omega$  typical)
- 44 V supply maximum rating
- $\pm 15$  V analog signal range
- Fully specified at supply voltages of  $\pm 4.5$  V, 12 V and  $\pm 15$  V
- TTL/CMOS compatible
- Break before make switching guaranteed
- Total harmonic distortion 0.0145 %
- Compliant to RoHS Directive 2002/95/EC



**RoHS**  
COMPLIANT

### APPLICATIONS

- Audio and video signal switching
- Precision automatic test equipment
- Precision data acquisition
- Relay replacement
- Communications systems
- Automotive applications
- Sample and hold systems
- Power routing applications
- Telecom signal switching
- Medical equipment
- Portable and battery power systems

### FUNCTIONAL BLOCK DIAGRAM AND PIN CONFIGURATION

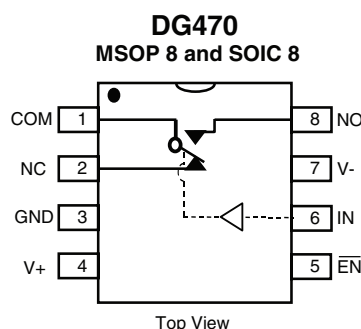
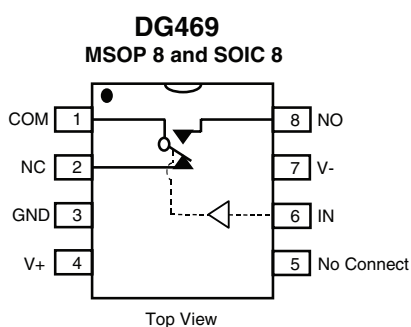

**TRUTH TABLE DG469**

| Logic | NC  | NO  |
|-------|-----|-----|
| 0     | ON  | OFF |
| 1     | OFF | ON  |

**TRUTH TABLE DG470**

| ENABLE | Logic | NC  | NO  |
|--------|-------|-----|-----|
| 0      | 0     | ON  | OFF |
| 0      | 1     | OFF | ON  |
| 1      | X     | OFF | OFF |

# DG469, DG470

Vishay Siliconix



| ORDERING INFORMATION           |                   |                                |
|--------------------------------|-------------------|--------------------------------|
| Temp. Range                    | Package           | Part Number                    |
| DG469, DG470                   |                   |                                |
| - 40 °C to 125 °C <sup>a</sup> | 8-Pin MSOP        | DG469EQ-T1-E3<br>DG470EQ-T1-E3 |
|                                | 8-Pin Narrow SOIC | DG469EY-T1-E3<br>DG470EY-T1-E3 |

Notes:

a. - 40 °C to 85 °C datasheet limits apply.

| ABSOLUTE MAXIMUM RATINGS $T_A = 25\text{ °C}$ , unless otherwise noted |  |      |    |
|--|--|------|----|
| Parameter  | Limit  | Unit |    |
| V+ to V-   | 44   | V    |    |
| GND to V-  | 25   |      |    |
| Digital Inputs <sup>a</sup> , $V_S$ , $V_D$                            | (V-) - 2 to (V+) + 2<br>or 30 mA, whichever occurs first |      |    |
| Continuous Current (NO, NC, or COM)                                    | 120  | mA   |    |
| Current (Any terminal except NO, NC, or COM)                           | 30   |      |    |
| Peak Current, (Pulsed 1 ms, 10 % Duty Cycle)                           | 200  |      |    |
| Storage Temperature  | - 65 to 150  | °C   |    |
| Power Dissipation (Package) <sup>b</sup>                               | 8-Pin MSOP <sup>c</sup>                                  | 320  | mW |
|  | 8-Pin Narrow SOIC <sup>d</sup>                           | 400  |    |

Notes:

a. Signals on  $S_X$ ,  $D_X$ , or  $IN_X$  exceeding V+ or V- will be clamped by internal diodes. Limit forward diode current to maximum current ratings.

b. All leads welded or soldered to PC board.

c. Derate 4.0 mW/°C above 70 °C.

d. Derate 5.0 mW/°C above 70 °C.

| SPECIFICATIONS for Dual Supplies |                 |   |                    |                   |                   |                   |                   |                   |      |  |
|----------------------------------|-----------------|---|--------------------|-------------------|-------------------|-------------------|-------------------|-------------------|------|--|
| Parameter                        | Symbol          | Test Conditions<br>Unless Specified<br>$V_+ = 15\text{ V}$ , $V_- = -15\text{ V}$<br>$V_{IN} = 2.4\text{ V}$ , $0.8\text{ V}^a$ | Temp. <sup>b</sup> | Typ. <sup>c</sup> | - 40 °C to 125 °C |                   | - 40 °C to 85 °C  |                   | Unit |  |
|                                  |                 |   |                    |                   | Min. <sup>d</sup> | Max. <sup>d</sup> | Min. <sup>d</sup> | Max. <sup>d</sup> |      |  |
| <b>Analog Switch</b>             |                 |   |                    |                   |                   |                   |                   |                   |      |  |
| Analog Signal Range <sup>e</sup> | $V_{ANALOG}$    |   | Full               |                   | - 15              | 15                | - 15              | 15                | V    |  |
| On-Resistance                    | $R_{ON}$        | $I_S = 50\text{ mA}$ , $V_D = -10\text{ V to }+10\text{ V}$   | Room<br>Full       | 3.6               |                   | 6<br>8            |                   | 6<br>7            | Ω    |  |
| On-Resistance Match              | $\Delta R_{ON}$ | $I_S = 50\text{ mA}$ , $V_D = \pm 10\text{ V}$  | Room<br>Full       | 0.12              |                   | 0.4<br>0.9        |                   | 0.4<br>0.5        |      |  |
| On-Resistance Flatness           | $R_{FLATNESS}$  | $I_S = 50\text{ mA}$ , $V_D = -5\text{ V}, 0\text{ V}, +5\text{ V}$   | Room<br>Full       | 0.4               |                   | 0.5<br>0.9        |                   | 0.5<br>0.8        |      |  |
| Switch Off<br>Leakage Current    | $I_{S(off)}$    | $V_D = \pm 14\text{ V}$ , $V_S = \pm 14\text{ V}$   | Room<br>Full       | ± 0.1             | - 0.5<br>- 20     | 0.5<br>20         | - 0.5<br>- 2.5    | 0.5<br>2.5        | nA   |  |
|                                  | $I_{D(off)}$    |   | Room<br>Full       | ± 0.1             | - 0.5<br>- 20     | 0.5<br>20         | - 0.5<br>- 2.5    | 0.5<br>2.5        |      |  |
| Channel On<br>Leakage Current    | $I_{D(on)}$     | $V_S = V_D = \pm 14\text{ V}$   | Room<br>Full       | ± 0.2             | - 0.5<br>- 20     | 0.5<br>20         | - 0.5<br>- 5      | 0.5<br>5          |      |  |
| <b>Digital Control</b>           |                 |   |                    |                   |                   |                   |                   |                   |      |  |
| Input Current, $V_{IN}$ Low      | $I_{IL}$        | $V_{IN}$ Under Test = 0.8 V   | Full               | 0.05              | - 1               | 1                 | - 1               | 1                 | μA   |  |
| Input Current, $V_{IN}$ High     | $I_{IH}$        | $V_{IN}$ Under Test = 2.4 V   | Full               | 0.05              | - 1               | 1                 | - 1               | 1                 |      |  |
| Input Capacitance <sup>e</sup>   | $C_{IN}$        | f = 1 MHz   | Room               | 3.7               |                   |                   |                   |                   | pF   |  |

**DG469, DG470**

Vishay Siliconix

| SPECIFICATIONS for Dual Supplies          |                  |   |                    |                   |                   |                   |                   |                   |               |
|---|------------------|---|--------------------|-------------------|-------------------|-------------------|-------------------|-------------------|---------------|
| Parameter                                 | Symbol           | Test Conditions<br>Unless Specified<br>$V_+ = 15\text{ V}$ , $V_- = -15\text{ V}$<br>$V_{IN} = 2.4\text{ V}$ , $0.8\text{ V}^a$ | Temp. <sup>b</sup> | Typ. <sup>c</sup> | -40 °C to 125 °C  |                   | -40 °C to 85 °C   |                   | Unit          |
|   |                  |   |                    |                   | Min. <sup>d</sup> | Max. <sup>d</sup> | Min. <sup>d</sup> | Max. <sup>d</sup> |               |
| <b>Dynamic Characteristics</b>            |                  |   |                    |                   |                   |                   |                   |                   |               |
| Turn-On Time                              | $t_{ON}$         | $R_L = 300\ \Omega$ , $C_L = 35\text{ pF}$<br>$V_S = \pm 10\text{ V}$   | Room Full          | 129               |                   | 166<br>200        |                   | 166<br>185        | ns            |
| Turn-Off Time                             | $t_{OFF}$        |   | Room Full          | 80                |                   | 108<br>135        |                   | 108<br>120        |               |
| Break-Before-Make Time Delay              | $t_D$            | $V_S = 10\text{ V}$<br>$R_L = 300\ \Omega$ , $C_L = 35\text{ pF}$   | Room               | 15                |                   |                   |                   |                   |               |
| Charge Injection <sup>e</sup>             | Q                | $V_g = 0\text{ V}$ , $R_g = 0\ \Omega$ , $C_L = 1\text{ nF}$  | Room               | 58                |                   |                   |                   |                   | pC            |
| Off Isolation <sup>e</sup>                | OIRR             | $R_L = 50\ \Omega$ , $C_L = 5\text{ pF}$<br>$f = 1\text{ MHz}$  | Room               | -57               |                   |                   |                   |                   | dB            |
| Channel-to-Channel Crosstalk <sup>e</sup> | $X_{TALK}$       |   | Room               | -63               |                   |                   |                   |                   |               |
| Source Off Capacitance <sup>e</sup>       | $C_{S(off)}$     |   | $f = 1\text{ MHz}$ | Room              | 37                |                   |                   |                   |               |
| Drain Off Capacitance <sup>e</sup>        | $C_{D(off)}$     | Room  |                    | 85                |                   |                   |                   |                   |               |
| Channel On Capacitance <sup>e</sup>       | $C_{D(on)}$      | Room  |                    | 125               |                   |                   |                   |                   |               |
| <b>Power Supplies</b>                     |                  |   |                    |                   |                   |                   |                   |                   |               |
| Power Supply Current                      | I+               | $V_+ = 16.5\text{ V}$ , $V_- = -16.5\text{ V}$<br>$V_{IN} = 0\text{ or }5\text{ V}$   | Room Full          | 3.0               |                   | 6<br>7            |                   | 6<br>7            | $\mu\text{A}$ |
| Negative Supply Current                   | I-               |   | Room Full          | -0.4              | -0.5<br>-4.5      |                   | -0.5<br>-4.5      |                   |               |
| Ground Current                            | I <sub>GND</sub> |   | Room Full          | -3.0              | -6<br>-7          |                   | -6<br>-7          |                   |               |

| SPECIFICATIONS for Dual Supplies     |                  |   |                    |                   |                   |                   |                   |                   |               |
|--------------------------------------|------------------|---|--------------------|-------------------|-------------------|-------------------|-------------------|-------------------|---------------|
| Parameter                            | Symbol           | Test Conditions<br>Unless Specified<br>$V_+ = 4.5\text{ V}$ , $V_- = -4.5\text{ V}$<br>$V_{IN} = 2.4\text{ V}$ , $0.8\text{ V}^a$ | Temp. <sup>b</sup> | Typ. <sup>c</sup> | -45 °C to 125 °C  |                   | -40 °C to 85 °C   |                   | Unit          |
|                                      |                  |   |                    |                   | Min. <sup>d</sup> | Max. <sup>d</sup> | Min. <sup>d</sup> | Max. <sup>d</sup> |               |
| <b>Analog Switch</b>                 |                  |   |                    |                   |                   |                   |                   |                   |               |
| Analog Signal Range <sup>e</sup>     | $V_{ANALOG}$     |   | Full               |                   | -4.5              | 4.5               | -4.5              | 4.5               | V             |
| On-Resistance <sup>e</sup>           | $R_{ON}$         | $I_S = 50\text{ mA}$ , $V_D = -2\text{ V to }+2\text{ V}$   | Room Full          | 8                 |                   | 11<br>16          |                   | 11<br>15          | $\Omega$      |
| On-Resistance Match <sup>e</sup>     | $\Delta R_{ON}$  | $I_S = 50\text{ mA}$ , $V_D = \pm 2\text{ V}$   | Room Full          | 0.6               |                   | 0.7<br>0.9        |                   | 0.7<br>0.8        |               |
| <b>Dynamic Characteristics</b>       |                  |   |                    |                   |                   |                   |                   |                   |               |
| Turn-On Time <sup>e</sup>            | $t_{ON}$         | $R_L = 300\ \Omega$ , $C_L = 35\text{ pF}$<br>$V_S = 2\text{ V}$  | Room Full          | 245               |                   | 265<br>340        |                   | 65<br>310         | ns            |
| Turn-Off Time <sup>e</sup>           | $t_{OFF}$        |   | Room Full          | 145               |                   | 163<br>200        |                   | 163<br>185        |               |
| Break-Before-Make Time Delay         | $t_D$            | $V_S = 2\text{ V}$<br>$R_L = 300\ \Omega$ , $C_L = 35\text{ pF}$  | Room Full          | 15                |                   |                   |                   |                   |               |
| Charge Injection <sup>e</sup>        | Q                | $V_g = 0\text{ V}$ , $R_g = 0\ \Omega$ , $C_L = 1\text{ nF}$  | Full               | 58                |                   |                   |                   |                   | pC            |
| <b>Power Supplies</b>                |                  |   |                    |                   |                   |                   |                   |                   |               |
| Power Supply Current <sup>e</sup>    | I+               | $V_{IN} = 0\text{ or }4.5\text{ V}$   | Room Full          | 3.0               |                   | 6<br>7            |                   | 6<br>7            | $\mu\text{A}$ |
| Negative Supply Current <sup>e</sup> | I-               |   | Room Full          | -0.4              | -0.5<br>-4.5      |                   | -0.5<br>-4.5      |                   |               |
| Ground Current <sup>e</sup>          | I <sub>GND</sub> |   | Room Full          | 3.0               | -6<br>-7          |                   | -6<br>-7          |                   |               |

# DG469, DG470

Vishay Siliconix



| SPECIFICATIONS for Unipolar Supplies |                       |   |                    |                   |                   |                   |                   |                   |      |
|--------------------------------------|-----------------------|---|--------------------|-------------------|-------------------|-------------------|-------------------|-------------------|------|
| Parameter                            | Symbol                | Test Conditions<br>Unless Specified<br>V <sub>+</sub> = 12 V, V <sub>-</sub> = 0 V<br>V <sub>IN</sub> = 2.4 V, 0.8 V <sup>a</sup> | Temp. <sup>b</sup> | Typ. <sup>c</sup> | - 40 °C to 125 °C |                   | - 40 °C to 85 °C  |                   | Unit |
|                                      |                       |   |                    |                   | Min. <sup>d</sup> | Max. <sup>d</sup> | Min. <sup>d</sup> | Max. <sup>d</sup> |      |
| <b>Analog Switch</b>                 |                       |   |                    |                   |                   |                   |                   |                   |      |
| Analog Signal Range <sup>e</sup>     | V <sub>ANALOG</sub>   |   | Full               |                   |                   | 12                |                   | 12                | V    |
| On-Resistance                        | R <sub>ON</sub>       | I <sub>S</sub> = 25 mA, V <sub>D</sub> = 0 V to + 10 V  | Room<br>Full       | 7.5               |                   | 8.5<br>14         |                   | 8.5<br>11.3       | Ω    |
| On-Resistance Match                  | ΔR <sub>ON</sub>      | I <sub>S</sub> = 25 mA, V <sub>D</sub> = + 10 V   | Room<br>Full       | 0.4               |                   | 0.45<br>0.9       |                   | 0.45<br>0.5       |      |
| On-Resistance Flatness               | R <sub>FLATNESS</sub> | I <sub>S</sub> = 25 mA,<br>V <sub>D</sub> = 0 V, + 5 V, + 10 V  | Room<br>Full       | 2.5               |                   | 2.6<br>2.9        |                   | 2.6<br>2.8        |      |
| <b>Dynamic Characteristics</b>       |                       |   |                    |                   |                   |                   |                   |                   |      |
| Turn-On Time                         | t <sub>ON</sub>       | R <sub>L</sub> = 300 Ω, C <sub>L</sub> = 35 pF<br>V <sub>S</sub> = 10 V   | Room<br>Full       | 190               |                   | 200<br>255        |                   | 200<br>240        | ns   |
| Turn-Off Time                        | t <sub>OFF</sub>      |   | Room<br>Full       | 100               |                   | 110<br>135        |                   | 110<br>120        |      |
| Break-Before-Make<br>Time Delay      | t <sub>D</sub>        | V <sub>S</sub> = 10 V<br>R <sub>L</sub> = 300 Ω, C <sub>L</sub> = 35 pF   | Room               | 50                |                   |                   |                   |                   |      |
| Charge Injection <sup>e</sup>        | Q                     | V <sub>g</sub> = 0 V, R <sub>g</sub> = 0 Ω, C <sub>L</sub> = 1 nF   | Room               | 2.4               |                   |                   |                   |                   | pC   |
| <b>Power Supplies</b>                |                       |   |                    |                   |                   |                   |                   |                   |      |
| Power Supply Current                 | I <sub>+</sub>        | V <sub>IN</sub> = 0 or 5 V  | Room<br>Full       | 3.0               |                   | 6<br>7            |                   | 6<br>7            | μA   |
| Negative Supply Current              | I <sub>-</sub>        |   | Room<br>Full       | - 0.4             | - 0.5<br>- 4.5    |                   | - 0.5<br>- 4.5    |                   |      |
| Ground Current                       | I <sub>GND</sub>      |   | Room<br>Full       | - 3.0             | - 6<br>- 7        |                   | - 6<br>- 7        |                   |      |

Notes:

- a. V<sub>IN</sub> = input voltage to perform proper function.
- b. Room = 25 °C, Full = as determined by the operating temperature suffix.
- c. Typical values are for DESIGN AID ONLY, not guaranteed nor subject to production testing.
- d. The algebraic convention whereby the most negative value is a minimum and the most positive a maximum, is used in this data sheet.
- e. Guaranteed by design, not subject to production test.

Stresses beyond those listed under "Absolute Maximum Ratings" may cause permanent damage to the device. These are stress ratings only, and functional operation of the device at these or any other conditions beyond those indicated in the operational sections of the specifications is not implied. Exposure to absolute maximum rating conditions for extended periods may affect device reliability.



**DG469, DG470**  
Vishay Siliconix

**TYPICAL CHARACTERISTICS**

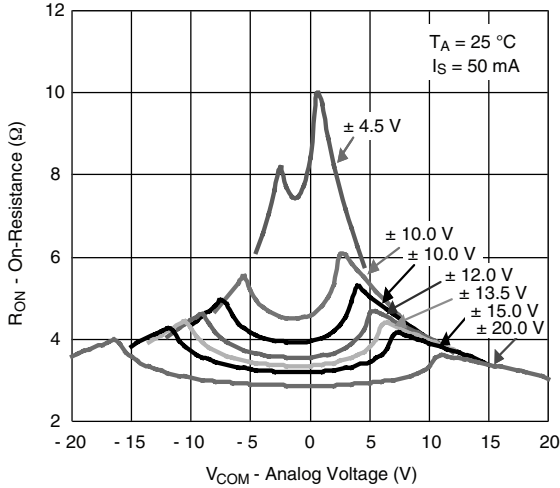

**On-Resistance vs.  $V_D$  and Dual Supply Voltage**

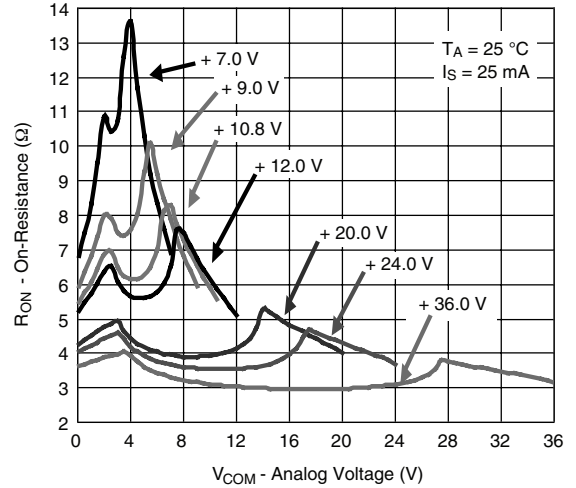

**On-Resistance vs.  $V_D$  and Single Supply Voltage**

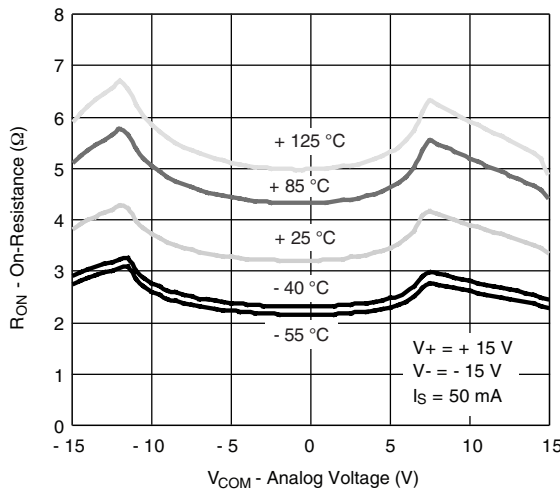

**On-Resistance vs.  $V_D$  and Temperature**

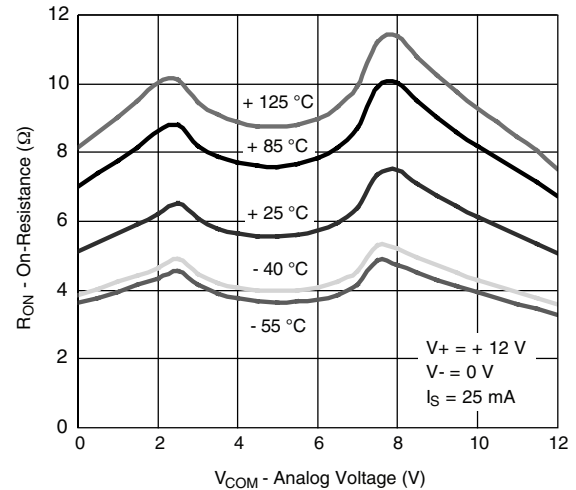

**On-Resistance vs.  $V_D$  and Temperature**

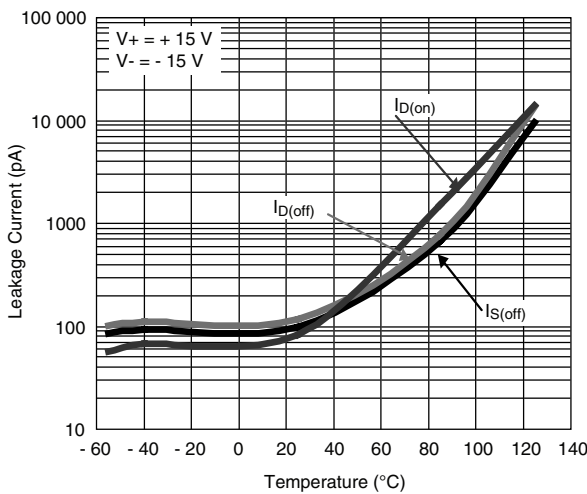

**Leakage Current vs. Temperature**

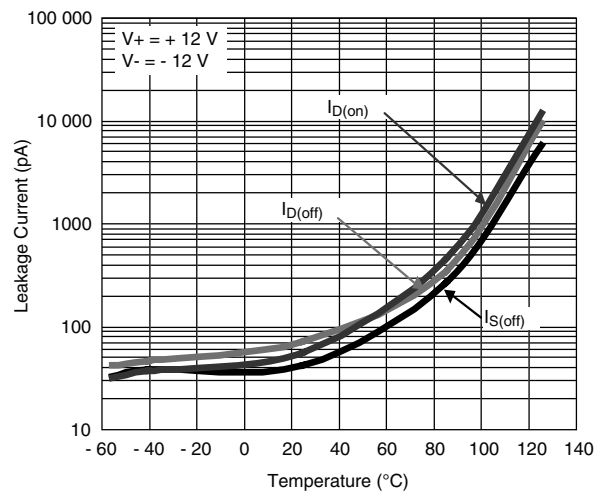

**Leakage Current vs. Temperature**

# DG469, DG470

Vishay Siliconix



## TYPICAL CHARACTERISTICS

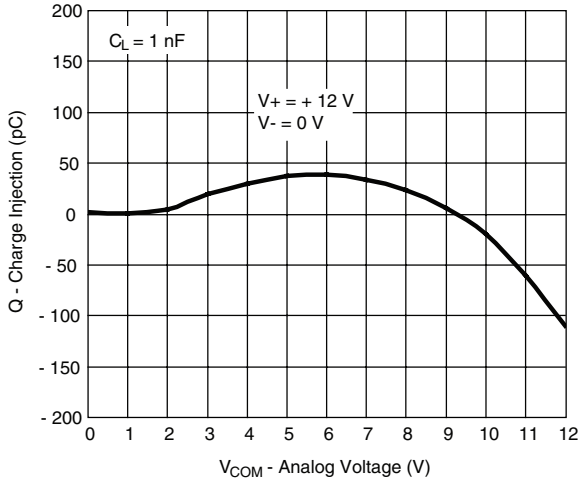

**Charge Injection vs. Analog Voltage**

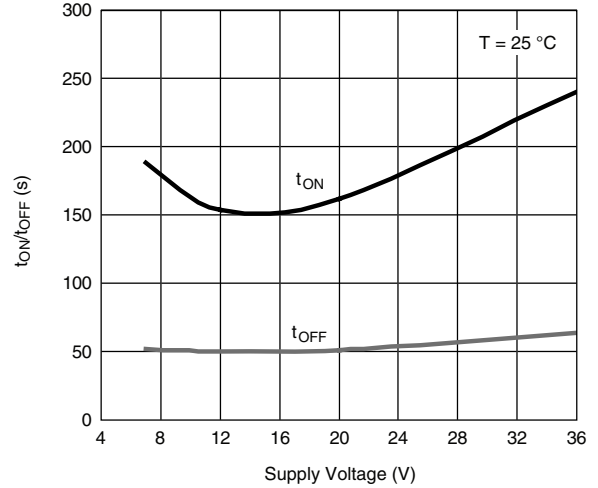

**Switching Time vs. Single Supply Voltage**

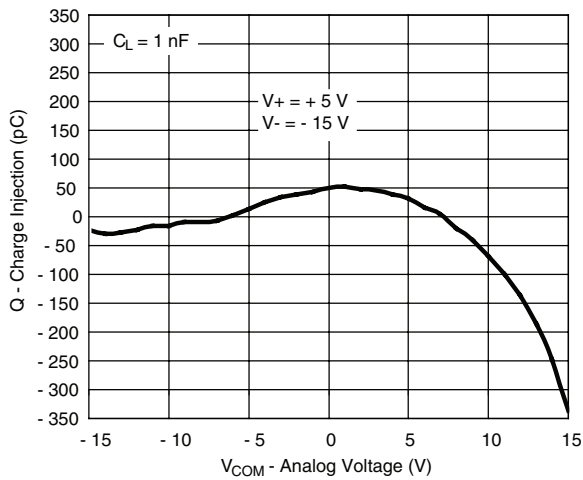

**Charge Injection vs. Analog Voltage**

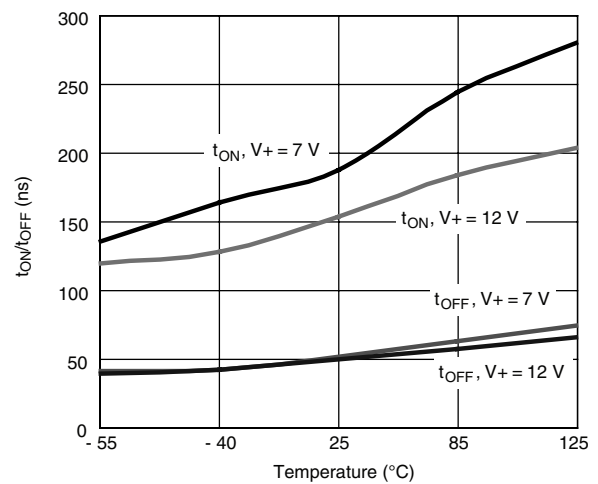

**Switching Time vs. Temperature and Single Supply Voltage**

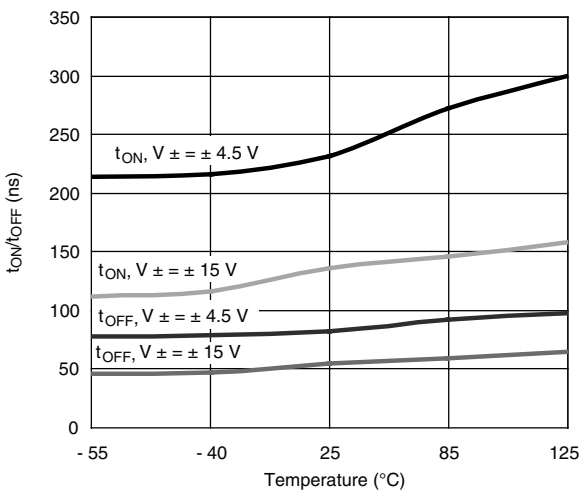

**Switching Time vs. Temperature and Dual Supply Voltage**

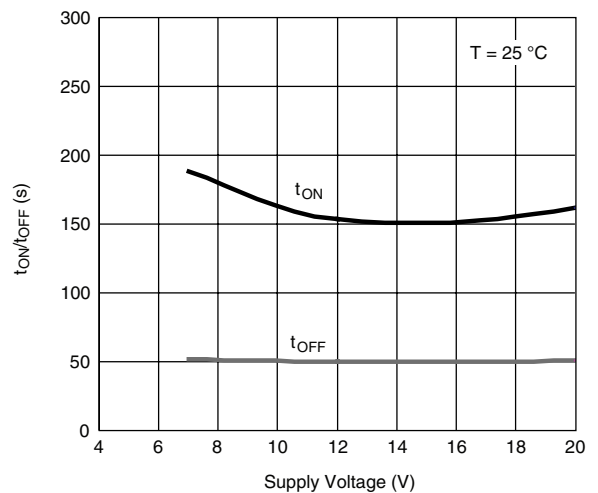

**Switching Time vs. Dual Supply Voltage**



**DG469, DG470**  
Vishay Siliconix

**TYPICAL CHARACTERISTICS**

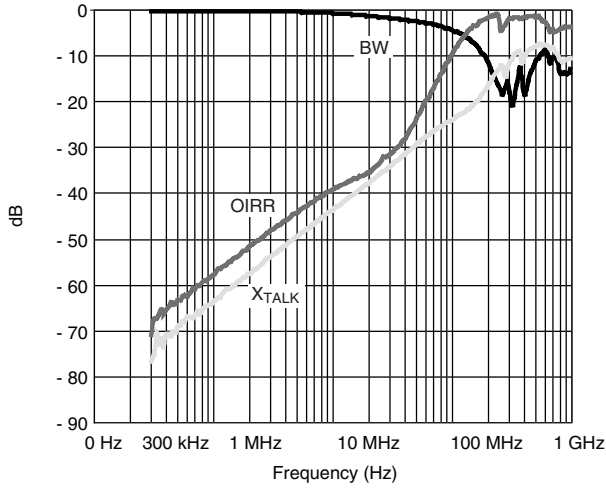

**Insertion Loss, Off-Isolation, Crosstalk vs. Frequency**

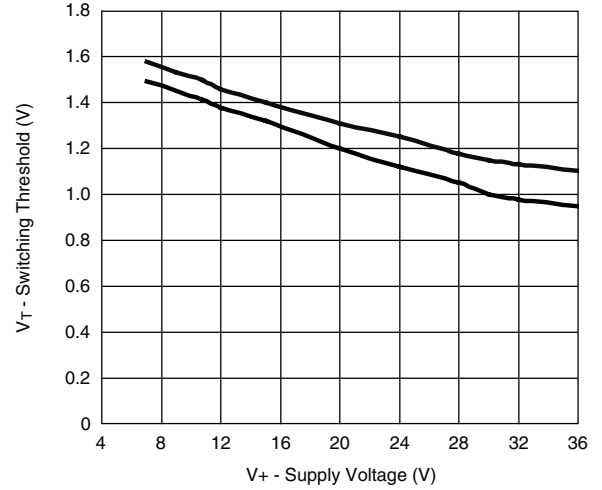

**Switching Threshold vs. Signal Supply Voltage**

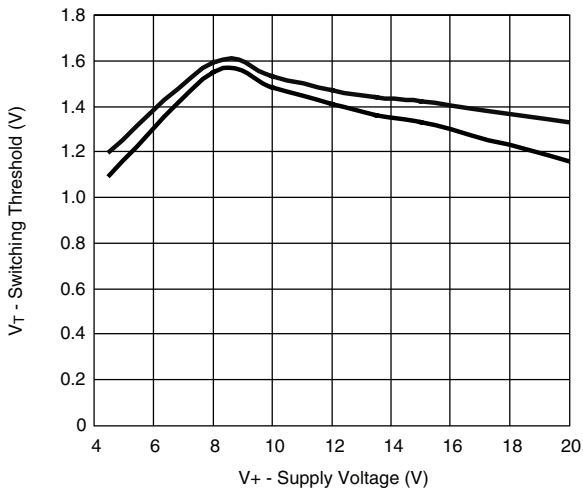

**Switching Threshold vs. Dual Supply Voltage**

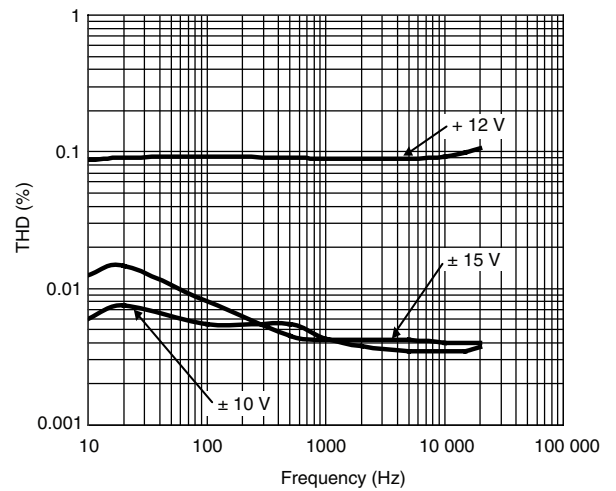

**DG469, DG470 Total Harmonic Distortion**

**TEST CIRCUITS**

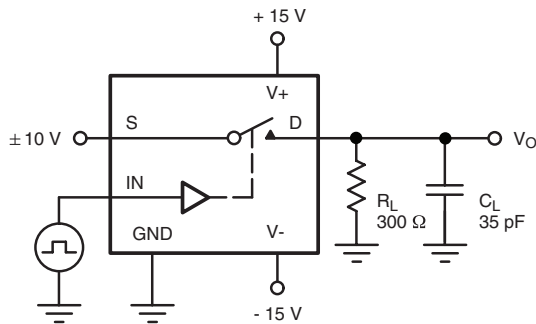

$C_L$  (includes fixture and stray capacitance)

$$V_O = V_S \frac{R_L}{R_L + r_{DS(on)}}$$

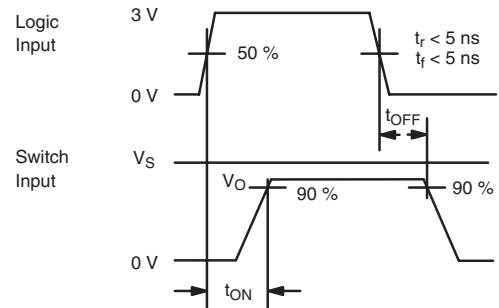

Note: Logic input waveform is inverted for switches that have the opposite logic sense control.

**Figure 1. Switching Time**



# DG469, DG470

Vishay Siliconix



## TEST CIRCUITS

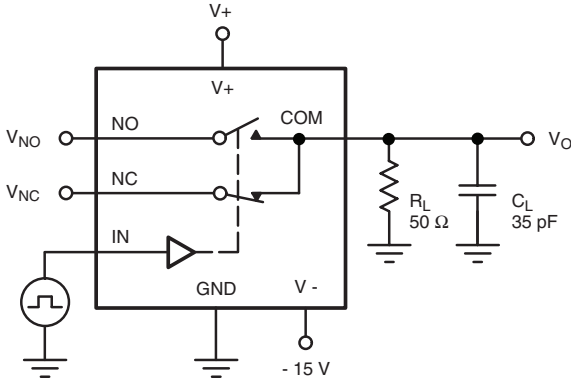

$C_L$  (includes fixture and stray capacitance)

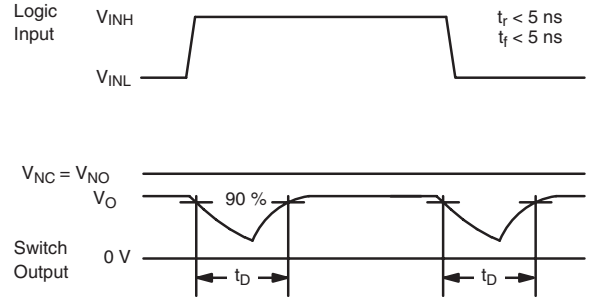

**Figure 2. Break-Before-Make**

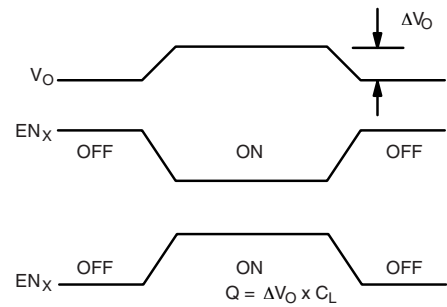
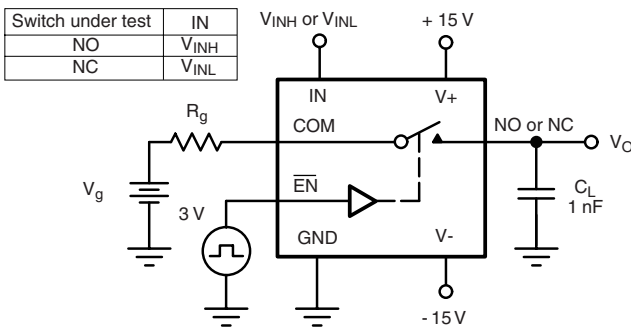

**Figure 3. Charge Injection**

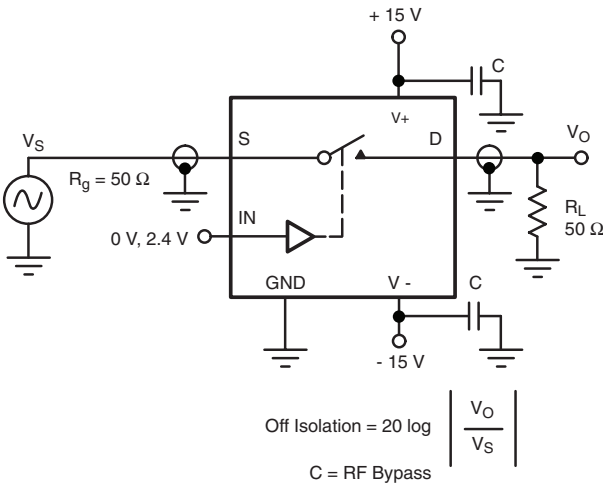

**Figure 4. Off-Isolation**

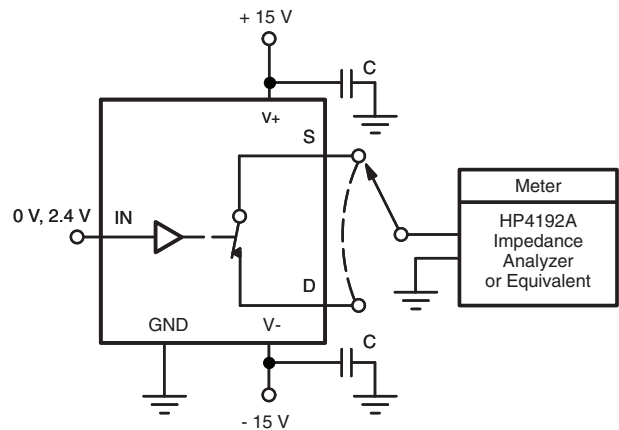

**Figure 5. Source/Drain Capacitances**

Vishay Siliconix maintains worldwide manufacturing capability. Products may be manufactured at one of several qualified locations. Reliability data for Silicon Technology and Package Reliability represent a composite of all qualified locations. For related documents such as package/tape drawings, part marking, and reliability data, see [www.vishay.com/ppg271470](http://www.vishay.com/ppg271470).



## Legal Disclaimer Notice

Vishay

### Disclaimer

All product specifications and data are subject to change without notice.

Vishay Intertechnology, Inc., its affiliates, agents, and employees, and all persons acting on its or their behalf (collectively, "Vishay"), disclaim any and all liability for any errors, inaccuracies or incompleteness contained herein or in any other disclosure relating to any product.

Vishay disclaims any and all liability arising out of the use or application of any product described herein or of any information provided herein to the maximum extent permitted by law. The product specifications do not expand or otherwise modify Vishay's terms and conditions of purchase, including but not limited to the warranty expressed therein, which apply to these products.

No license, express or implied, by estoppel or otherwise, to any intellectual property rights is granted by this document or by any conduct of Vishay.

The products shown herein are not designed for use in medical, life-saving, or life-sustaining applications unless otherwise expressly indicated. Customers using or selling Vishay products not expressly indicated for use in such applications do so entirely at their own risk and agree to fully indemnify Vishay for any damages arising or resulting from such use or sale. Please contact authorized Vishay personnel to obtain written terms and conditions regarding products designed for such applications.

Product names and markings noted herein may be trademarks of their respective owners.