

## Excellent Integrated System Limited

Stocking Distributor

Click to view price, real time Inventory, Delivery & Lifecycle Information:

[STMicroelectronics](#)  
[VN800PT-E](#)

For any questions, you can email us directly:

[sales@integrated-circuit.com](mailto:sales@integrated-circuit.com)



# VN800PT-E

## High-side driver

Datasheet – production data

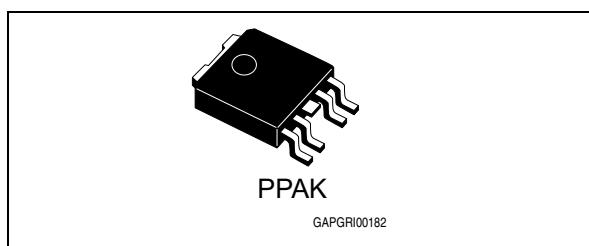

### Description

The VN800PT-E is a monolithic device manufactured using STMicroelectronics® VIPower® M0-3 technology, intended for driving any kind of load with one side connected to ground.

Active  $V_{CC}$  pin voltage clamp protects the device against low energy spikes.

Active current limitation combined with thermal shutdown and automatic restart protect the device against overload.

Device automatically turns off in case of ground pin disconnection. This device is especially suitable for industrial applications in norms conformity with IEC1131 (Programmable Controllers International Standard).

### Features

Type	$R_{DS(on)}$	$I_{OUT}$	$V_{CC}$
VN800PT-E	135 m $\Omega$	0.7 A	36 V

- CMOS compatible input
- Thermal shutdown
- Current limitation
- Shorted load protection
- Undervoltage and overvoltage shutdown
- Protection against loss of ground
- Very low stand-by current
- Reverse battery protection
- Compliant with European directive 2002/95/EC

**Table 1. Device summary**

Package	Order code	
	Tube	Tape and reel
PPAK	VN800PT-E	VN800PTTR-E

# Contents

<b>1</b>	<b>Block diagram and pin description</b>	<b>5</b>
<b>2</b>	<b>Electrical specifications</b>	<b>6</b>
2.1	Absolute maximum ratings	6
2.2	Thermal data	7
2.3	Electrical characteristics	8
<b>3</b>	<b>Electrical characteristics curves</b>	<b>14</b>
3.1	Application information	16
3.2	GND protection network against reverse battery	16
3.2.1	Solution 1: resistor in the ground line (RGND only).	16
3.3	Solution 2: a diode (DGND) in the ground line	17
3.3.1	MCU I/Os protection	17
3.4	PPAK maximum demagnetization energy ( $V_{CC} = 13.5\text{ V}$ )	18
<b>4</b>	<b>Package and PCB thermal data</b>	<b>19</b>
4.1	PPAK thermal data	19
<b>5</b>	<b>Package and packing information</b>	<b>22</b>
5.1	ECOPACK <sup>®</sup>	22
5.2	PPAK package mechanical data	22
5.2.1	PPAK packing information	24
<b>6</b>	<b>Revision history</b>	<b>25</b>

## List of tables

Table 1.	Device summary . . . . .	1
Table 2.	Suggested connections for unused and n.c. pins . . . . .	5
Table 3.	Absolute maximum ratings . . . . .	6
Table 4.	Thermal data . . . . .	7
Table 5.	Power . . . . .	8
Table 6.	Switching ( $V_{CC} = 24 V$ ) . . . . .	8
Table 7.	Input pin . . . . .	8
Table 8.	VCC output diode . . . . .	9
Table 9.	Status pin . . . . .	9
Table 10.	Protections . . . . .	9
Table 11.	Truth table . . . . .	10
Table 12.	Electrical transient requirements on VCC pin (part 1/3) . . . . .	11
Table 13.	Electrical transient requirements on VCC pin (part 2/3) . . . . .	11
Table 14.	Electrical transient requirements on VCC pin (part 3/3) . . . . .	11
Table 15.	Thermal parameter . . . . .	21
Table 16.	PPAK mechanical data . . . . .	23
Table 17.	Revision history . . . . .	25

## List of figures

Figure 1.	Block diagram . . . . .	5
Figure 2.	Configuration diagram (top view) . . . . .	5
Figure 3.	Current and voltage conventions . . . . .	6
Figure 4.	Status timings . . . . .	10
Figure 5.	Switching time waveforms . . . . .	10
Figure 6.	Peak short circuit current test circuit. . . . .	12
Figure 7.	Avalanche energy test circuit . . . . .	12
Figure 8.	Waveforms . . . . .	13
Figure 9.	Off-state output current. . . . .	14
Figure 10.	High level input current. . . . .	14
Figure 11.	Status leakage current . . . . .	14
Figure 12.	On-state resistance vs $V_{CC}$ . . . . .	14
Figure 13.	On-state resistance vs $T_{case}$ . . . . .	14
Figure 14.	Input high level . . . . .	14
Figure 15.	Input low level. . . . .	15
Figure 16.	Input hysteresis voltage . . . . .	15
Figure 17.	Turn-on voltage slope . . . . .	15
Figure 18.	Turn-off voltage slope . . . . .	15
Figure 19.	Overvoltage shutdown . . . . .	15
Figure 20.	$I_{LIM}$ vs $T_{case}$ . . . . .	15
Figure 21.	Application schematic. . . . .	16
Figure 22.	PPAK maximum turn-off current versus load inductance . . . . .	18
Figure 23.	PPAK PC board . . . . .	19
Figure 24.	PPAK $R_{thj-amb}$ vs PCB copper area in open box free air condition . . . . .	19
Figure 25.	PPAK thermal impedance junction ambient single pulse . . . . .	20
Figure 26.	Thermal fitting model of a single channel HSD in PPAK . . . . .	20
Figure 27.	PPAK package dimensions . . . . .	22
Figure 28.	PPAK suggested pad layout and tube shipment (no suffix) . . . . .	24
Figure 29.	PPAK tape and reel shipment (suffix "TR"). . . . .	24

# 1 Block diagram and pin description

Figure 1. Block diagram

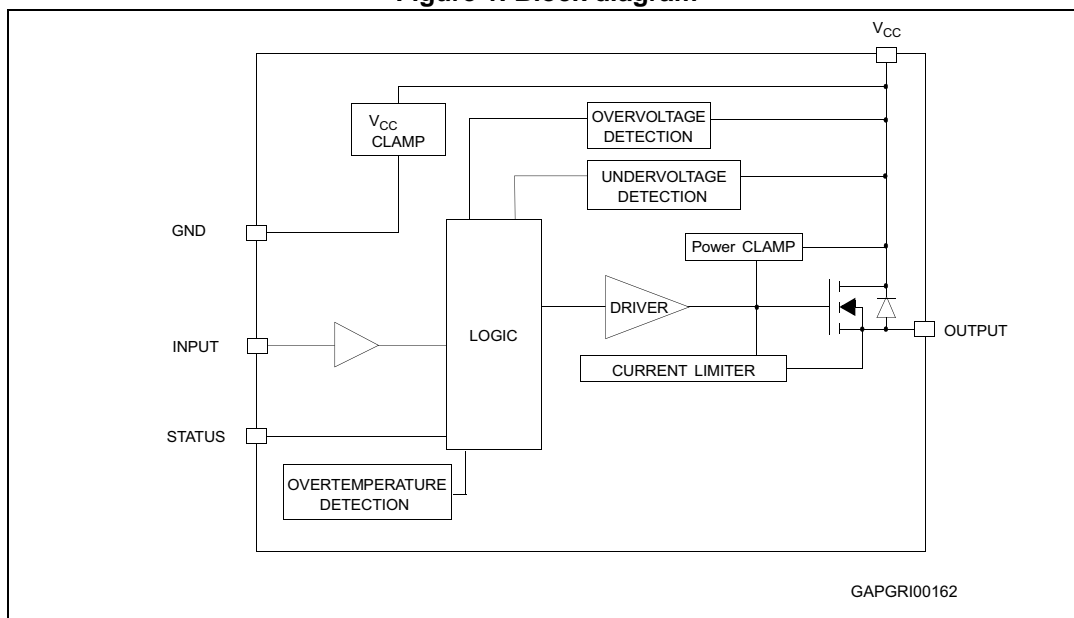

Figure 2. Configuration diagram (top view)

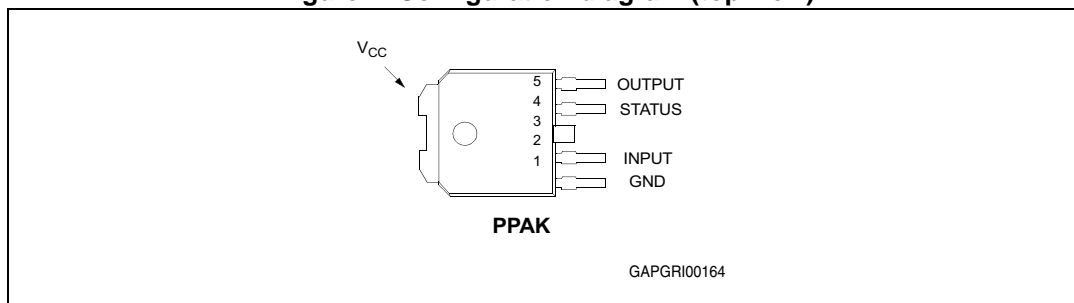

Table 2. Suggested connections for unused and n.c. pins

Connection / Pin	Status	N.C.	Output	Input
Floating	X <sup>(1)</sup>	X	X	X
To ground		X		Through 10 kΩ resistor

1. X: do not care.

## 2 Electrical specifications

Figure 3. Current and voltage conventions

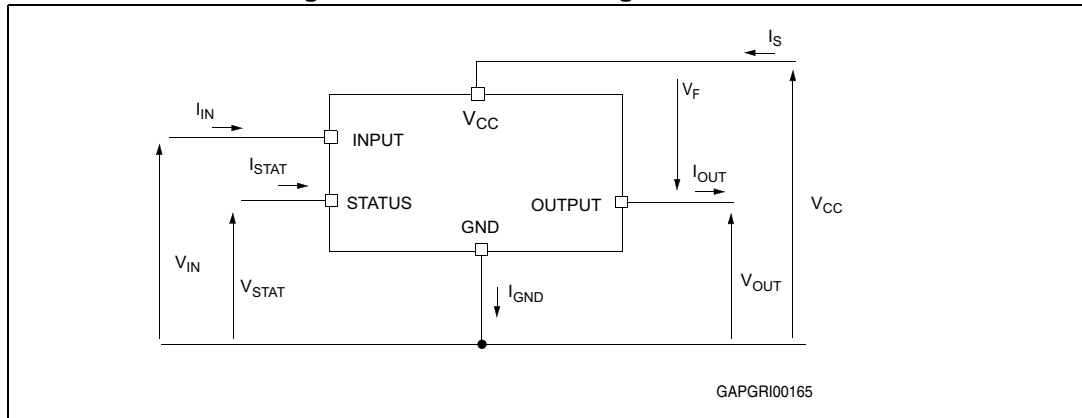

### 2.1 Absolute maximum ratings

Stressing the device above the rating listed in the [Table 4](#) may cause permanent damage to the device. These are stress ratings only and operation of the device at these or any other conditions above those indicated in the operating sections of this specification is not implied. Exposure to Absolute maximum rating conditions for extended periods may affect device reliability.

Table 3. Absolute maximum ratings

Symbol	Parameter	Value	Unit
$V_{CC}$	DC supply voltage	41	V
$-V_{CC}$	Reverse DC supply voltage	-0.3	V
$-I_{GND}$	DC reverse ground pin current	-200	mA
$I_{OUT}$	DC output current	Internally limited	A
$-I_{OUT}$	Reverse DC output current	-6	A
$I_{IN}$	DC input current	+/- 10	mA
$V_{IN}$	Input voltage range	$-3/+V_{CC}$	V
$V_{STAT}$	DC Status voltage	$+ V_{CC}$	V
$V_{ESD}$	Electrostatic discharge (human body model: R = 1.5 k $\Omega$ ; C = 100 pF)		
	- INPUT	4000	V
	- STATUS	4000	V
	- OUTPUT	5000	V
	- $V_{CC}$	5000	V
$P_{tot}$	Power dissipation $T_C = 25\text{ }^\circ\text{C}$	41.7	W
$E_{MAX}$	Maximum switching energy (L = 125 mH; $R_L = 0\text{ }\Omega$ ; $V_{bat} = 13.5\text{ V}$ ; $T_{jstart} = 150\text{ }^\circ\text{C}$ ; $I_L = 1.5\text{ A}$ )	195	mJ

VN800PT-E

Electrical specifications

Table 3. Absolute maximum ratings (continued)

Symbol	Parameter	Value	Unit
$T_j$	Junction operating temperature	Internally limited	°C
$T_c$	Case operating temperature	-40 to 150	°C
$T_{stg}$	Storage temperature	-55 to 150	°C
$L_{max}$	Max inductive load ( $V_{CC} = 30\text{ V}$ ; $I_{LOAD} = 0.5\text{ A}$ ; $T_{amb} = 100\text{ °C}$ ; $R_{th_{case>ambient}} \leq 25\text{ °C/W}$ )	2	H

## 2.2 Thermal data

Table 4. Thermal data

Symbol	Parameter	Value (Max)	Unit
$R_{thj-case}$	Thermal resistance junction-case	3	°C/W
$R_{thj-lead}$	Thermal resistance junction-lead	—	°C/W
$R_{thj-amb}$	Thermal resistance junction-ambient	78 <sup>(1)</sup>	°C/W
		45 <sup>(2)</sup>	°C/W

1. When mounted on FR4 printed circuit board with 2 cm<sup>2</sup> of copper area (at least 35 μm thick).
2. When mounted on FR4 printed circuit board with 6 cm<sup>2</sup> of copper area (at least 35 μm thick).



## Electrical specifications

## VN800PT-E

### 2.3 Electrical characteristics

Values specified in this section are for  $8\text{ V} < V_{CC} < 36\text{ V}$ ;  $-40\text{ }^{\circ}\text{C} < T_j < 150\text{ }^{\circ}\text{C}$  unless otherwise specified.

**Table 5. Power**

Symbol	Parameter	Test conditions	Min.	Typ.	Max.	Unit
$V_{CC}$	Operating supply voltage		5.5		36	V
$V_{USD}$	Undervoltage shutdown		3	4	5.5	V
$V_{OV}$	Overvoltage shutdown		36	42		V
$R_{ON}$	On-state resistance	$I_{OUT} = 0.5\text{ A}$ ; $T_j = 25\text{ }^{\circ}\text{C}$			135	m $\Omega$
		$I_{OUT} = 0.5\text{ A}$			270	m $\Omega$
$I_S$	Supply current	Off-state; $V_{CC} = 24\text{ V}$ ; $T_{case} = 25\text{ }^{\circ}\text{C}$		10	20	$\mu\text{A}$
		On-state; $V_{CC} = 24\text{ V}$		1.5	3.5	mA
		On-state; $V_{CC} = 24\text{ V}$ ; $T_{case} = 100\text{ }^{\circ}\text{C}$			2.6	mA
$I_{LGND}$	Output current at turn-off	$V_{CC} = V_{STAT} = V_{IN} = V_{GND} = 24\text{ V}$ ; $V_{OUT} = 0\text{ V}$			1	mA
$I_{L(off1)}$	Off-state output current	$V_{IN} = V_{OUT} = 0\text{ V}$	0		50	$\mu\text{A}$
$I_{L(off2)}$	Off-state output current	$V_{IN} = V_{OUT} = 0\text{ V}$ ; $V_{CC} = 13\text{ V}$ ; $T_j = 125\text{ }^{\circ}\text{C}$			5	$\mu\text{A}$
$I_{L(off3)}$	Off-state output current	$V_{IN} = V_{OUT} = 0\text{ V}$ ; $V_{CC} = 13\text{ V}$ ; $T_j = 25\text{ }^{\circ}\text{C}$			3	$\mu\text{A}$

**Table 6. Switching ( $V_{CC} = 24\text{ V}$ )**

Symbol	Parameter	Test conditions	Min.	Typ.	Max.	Unit
$t_{d(on)}$	Turn-on delay time	$R_L = 48\text{ }\Omega$ from $V_{IN}$ rising edge to $V_{OUT} = 2.4\text{ V}$	—	10	—	$\mu\text{s}$
$t_{d(off)}$	Turn-off delay time	$R_L = 48\text{ }\Omega$ from $V_{IN}$ falling edge to $V_{OUT} = 21.6\text{ V}$	—	40	—	$\mu\text{s}$
$dV_{OUT}/dt_{(on)}$	Turn-on voltage slope	$R_L = 48\text{ }\Omega$ from $V_{OUT} = 2.4\text{ V}$ to $V_{OUT} = 19.2\text{ V}$	—	See Figure 17	—	V/ $\mu\text{s}$
$dV_{OUT}/dt_{(off)}$	Turn-off voltage slope	$R_L = 48\text{ }\Omega$ from $V_{OUT} = 21.6\text{ V}$ to $V_{OUT} = 2.4\text{ V}$	—	See Figure 18	—	V/ $\mu\text{s}$

**Table 7. Input pin**

Symbol	Parameter	Test conditions	Min.	Typ.	Max.	Unit
$V_{INL}$	Input low level				1.25	V
$I_{INL}$	Low level input current	$V_{IN} = 1.25\text{ V}$	1			$\mu\text{A}$
$V_{INH}$	Input high level		3.25			V

**VN800PT-E**
**Electrical specifications**
**Table 7. Input pin (continued)**

Symbol	Parameter	Test conditions	Min.	Typ.	Max.	Unit
$I_{INH}$	High level input current	$V_{IN} = 3.25\text{ V}$			10	$\mu\text{A}$
$V_{I(hyst)}$	Input hysteresis voltage		0.5			V
$I_{IN}$	Input current	$V_{IN} = V_{CC} = 36\text{ V}$			200	$\mu\text{A}$

**Table 8.  $V_{CC}$  output diode**

Symbol	Parameter	Test conditions	Min.	Typ.	Max.	Unit
$V_F$	Forward on voltage	$-I_{OUT} = 0.6\text{ A}; T_j = 150\text{ }^\circ\text{C}$	—	—	0.6	V

**Table 9. Status pin**

Symbol	Parameter	Test conditions	Min	Typ	Max	Unit
$V_{STAT}$	Status low output voltage	$I_{STAT} = 1.6\text{ mA}$	—	—	0.5	V
$I_{LSTAT}$	Status leakage current	Normal operation; $V_{STAT} = V_{CC} = 36\text{ V}$	—	—	10	$\mu\text{A}$
$C_{STAT}$	Status pin input capacitance	Normal operation; $V_{STAT} = 5\text{ V}$	—	—	30	pF

**Table 10. Protections**

Symbol	Parameter	Test conditions	Min	Typ	Max	Unit
$T_{TSD}$	Shut-down temperature	—	150	175	200	$^\circ\text{C}$
$T_R$	Reset temperature	—	135			$^\circ\text{C}$
$T_{hyst}$	Thermal hysteresis	—	7	15		$^\circ\text{C}$
$T_{SDL}$	Status delay in overload condition	$T_j > T_{jsh}$			20	$\mu\text{s}$
$I_{lim}$	DC short circuit current	$V_{CC} = 24\text{ V};$ $R_{LOAD} = 10\text{ m}\Omega$	0.7		2	A
$V_{demag}$	Turn-off output clamp voltage	$I_{OUT} = 0.5\text{ A}; L = 6\text{ mH}$	$V_{CC} - 47$	$V_{CC} - 52$	$V_{CC} - 57$	V

*Note:* To ensure long term reliability under heavy overload or short circuit conditions, protection and related diagnostic signals must be used together with a proper software strategy. If the device is subjected to abnormal conditions, this software must limit the duration and number of activation cycles.

**Electrical specifications**

**VN800PT-E**

**Figure 4. Status timings**

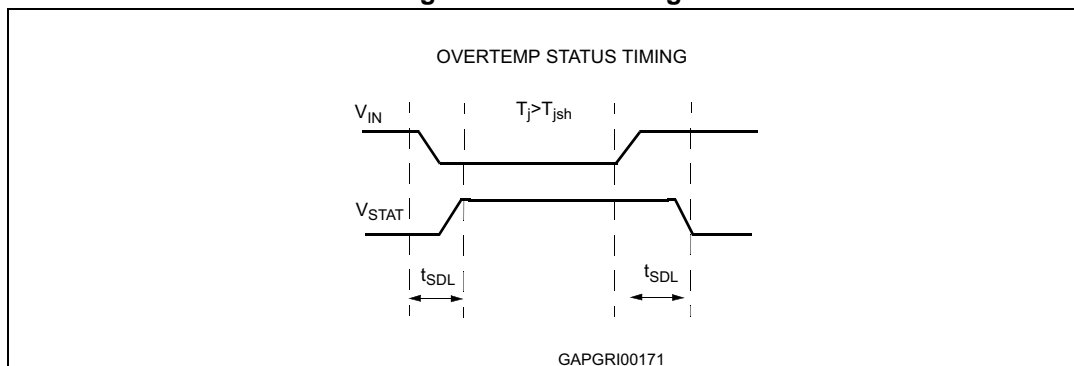

**Figure 5. Switching time waveforms**

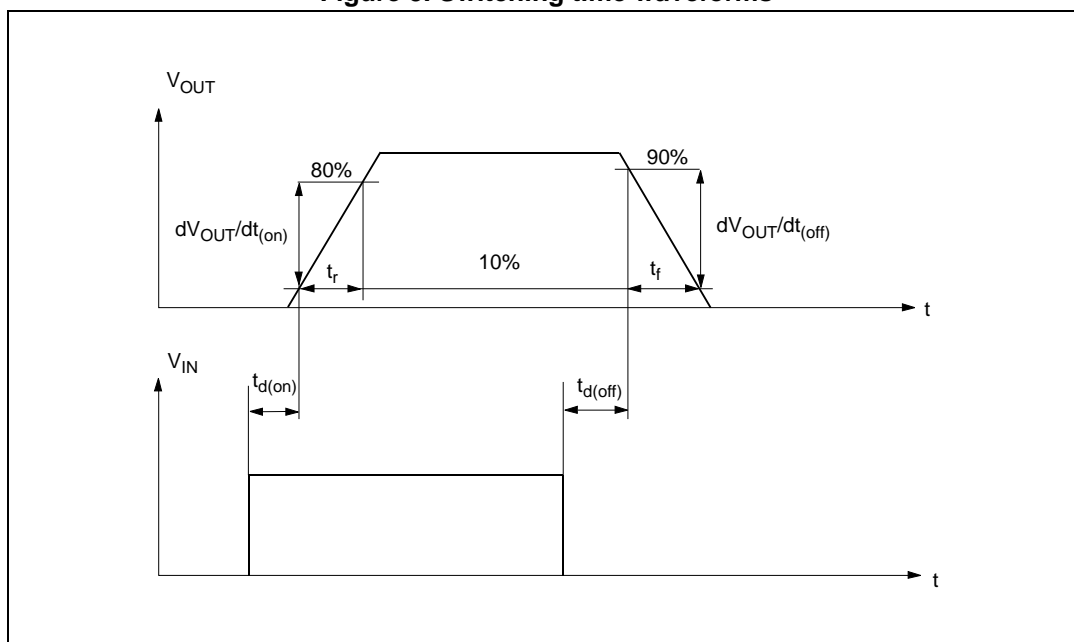

**Table 11. Truth table**

Conditions	Input	Output	Status
Normal operation	L	L	H
	H	H	H
Current limitation	L	L	H
	H	X	( $T_j < T_{TSD}$ ) H
	H	X	( $T_j > T_{TSD}$ ) L
Overtemperature	L	L	H
	H	L	L
Undervoltage	L	L	X
	H	L	X
Overvoltage	L	L	H
	H	L	H

VN800PT-E

Electrical specifications

Table 12. Electrical transient requirements on V<sub>CC</sub> pin (part 1/3)

ISO T/R 7637/1 Test Pulse	Test levels				Delays and Impedance
	I	II	III	IV	
1	-25 V	-50 V	-75 V	-100 V	2 ms, 10Ω
2	+25 V	+50 V	+75 V	+100 V	0.2 ms, 10 Ω
3a	-25 V	-50 V	-100 V	-150 V	0.1 μs, 50 Ω
3b	+25 V	+50 V	+75 V	+100 V	0.1 μs, 50 Ω
4	-4 V	-5 V	-6 V	-7 V	100 ms, 0.01 Ω
5	+26.5 V	+46.5 V	+66.5 V	+86.5 V	400 ms, 2 Ω

Table 13. Electrical transient requirements on V<sub>CC</sub> pin (part 2/3)

ISO T/R 7637/1 Test Pulse	TEST LEVELS			
	I	II	III	IV
1	C	C	C	C
2	C	C	C	C
3a	C	C	C	C
3b	C	C	C	C
4	C	C	C	C
5	C	E	E	E

Table 14. Electrical transient requirements on V<sub>CC</sub> pin (part 3/3)

Class	Contents
C	All functions of the device are performed as designed after exposure to disturbance.
E	One or more functions of the device is not performed as designed after exposure to disturbance and cannot be returned to proper operation without replacing the device.

**Electrical specifications**

**VN800PT-E**

**Figure 6. Peak short circuit current test circuit**

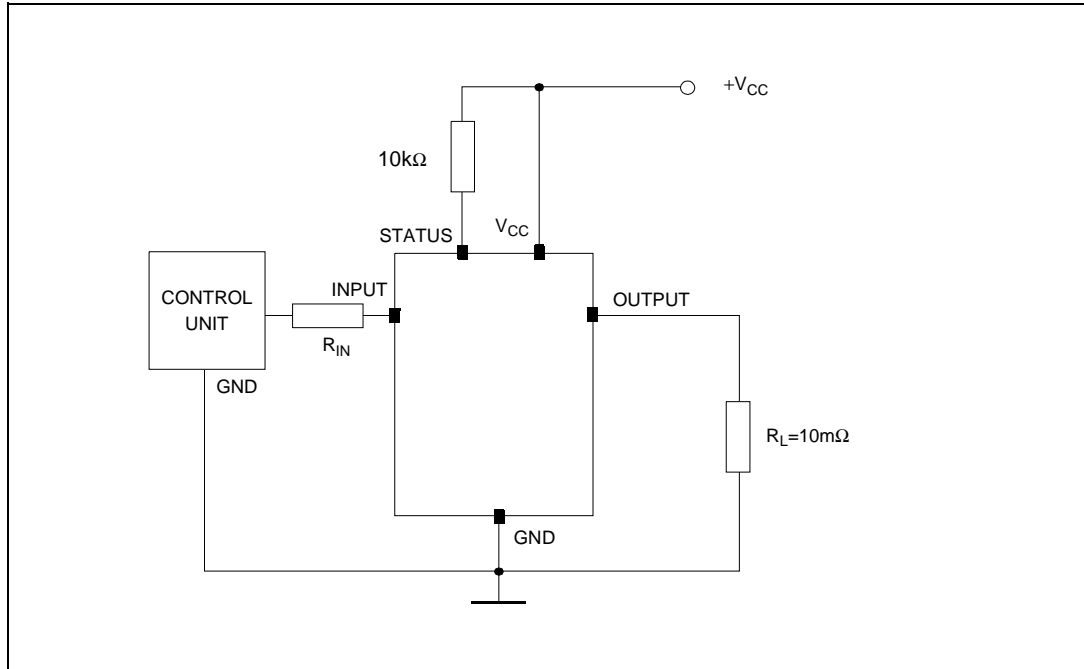

**Figure 7. Avalanche energy test circuit**

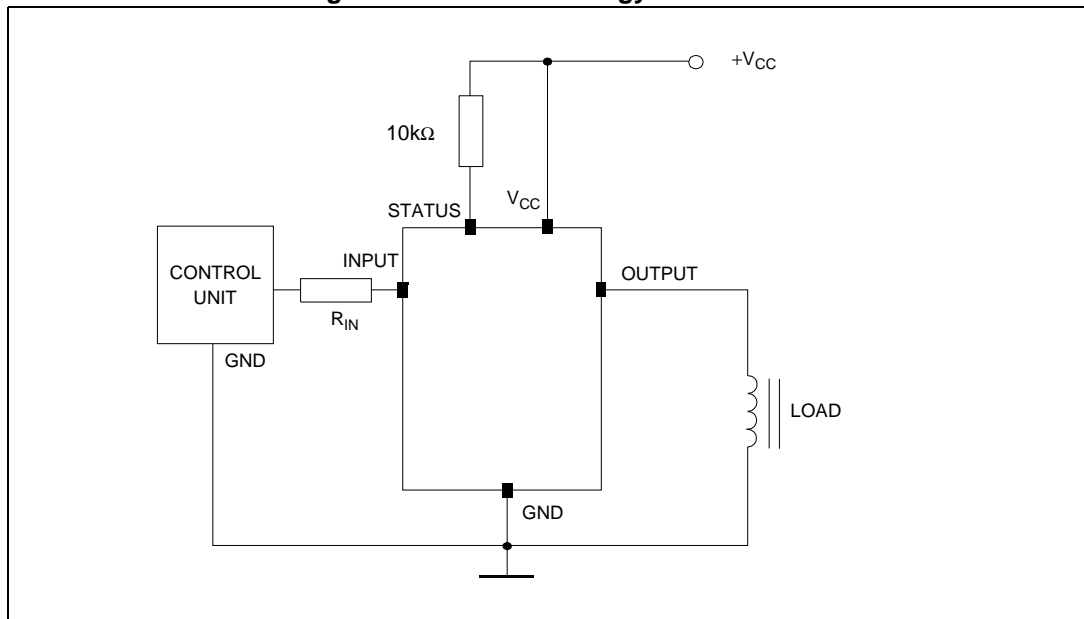

**VN800PT-E**

**Electrical specifications**

**Figure 8. Waveforms**

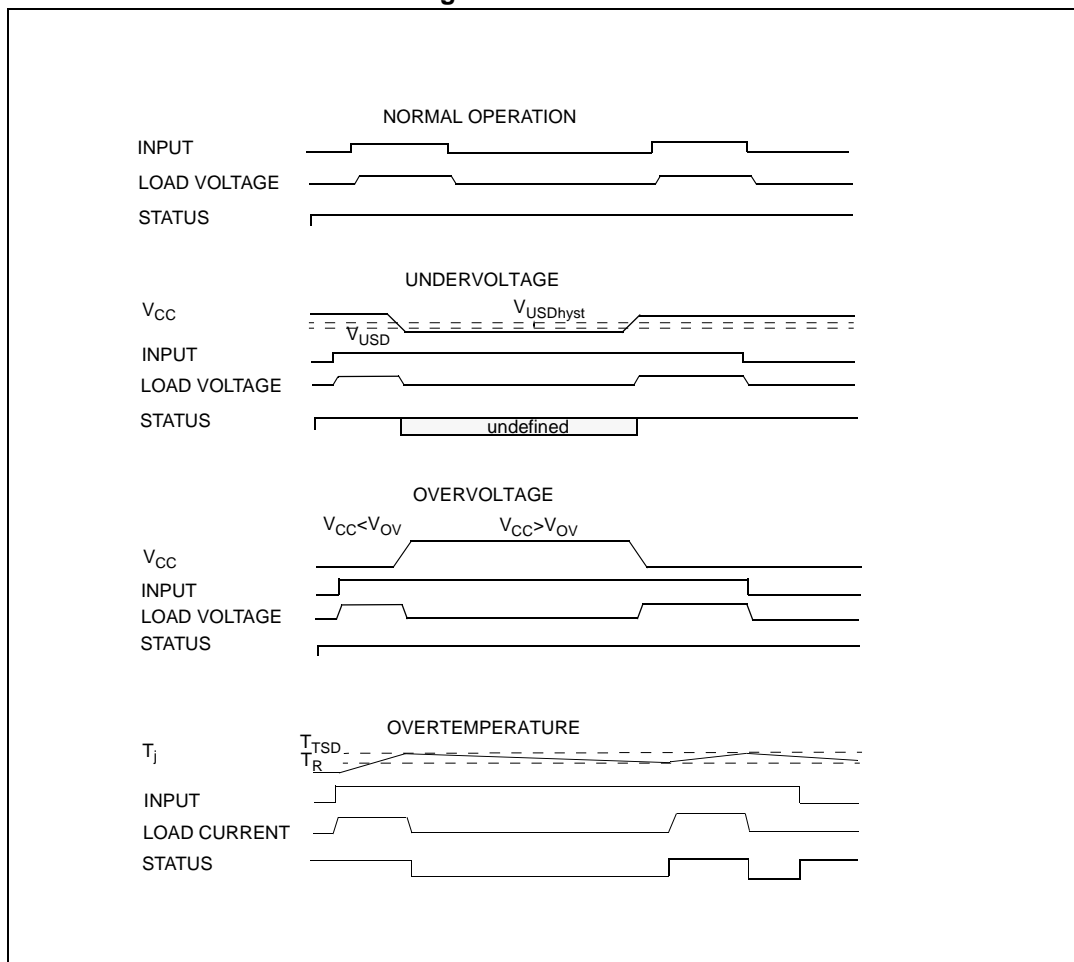

**3 Electrical characteristics curves**

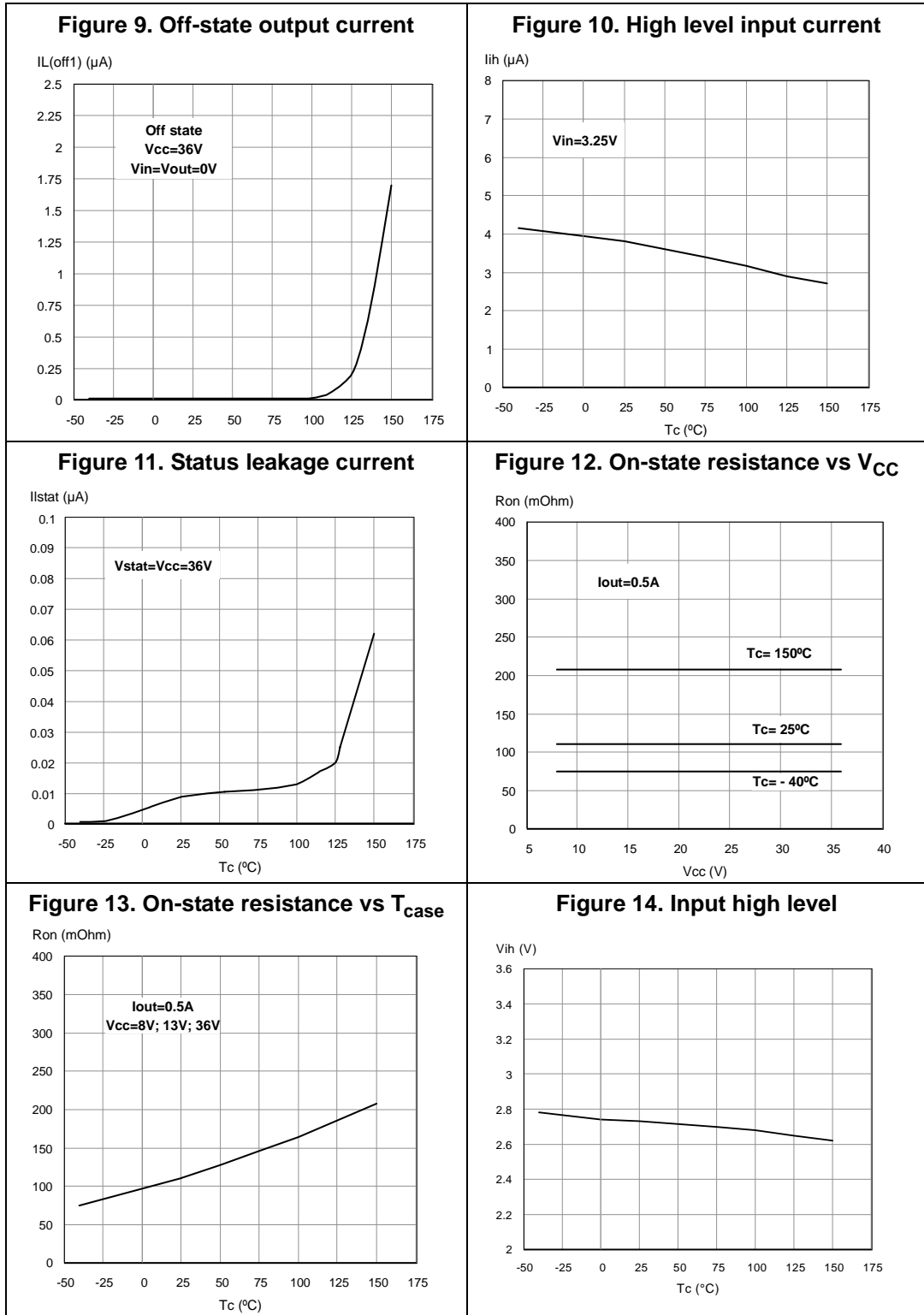

**VN800PT-E**

**Electrical characteristics curves**

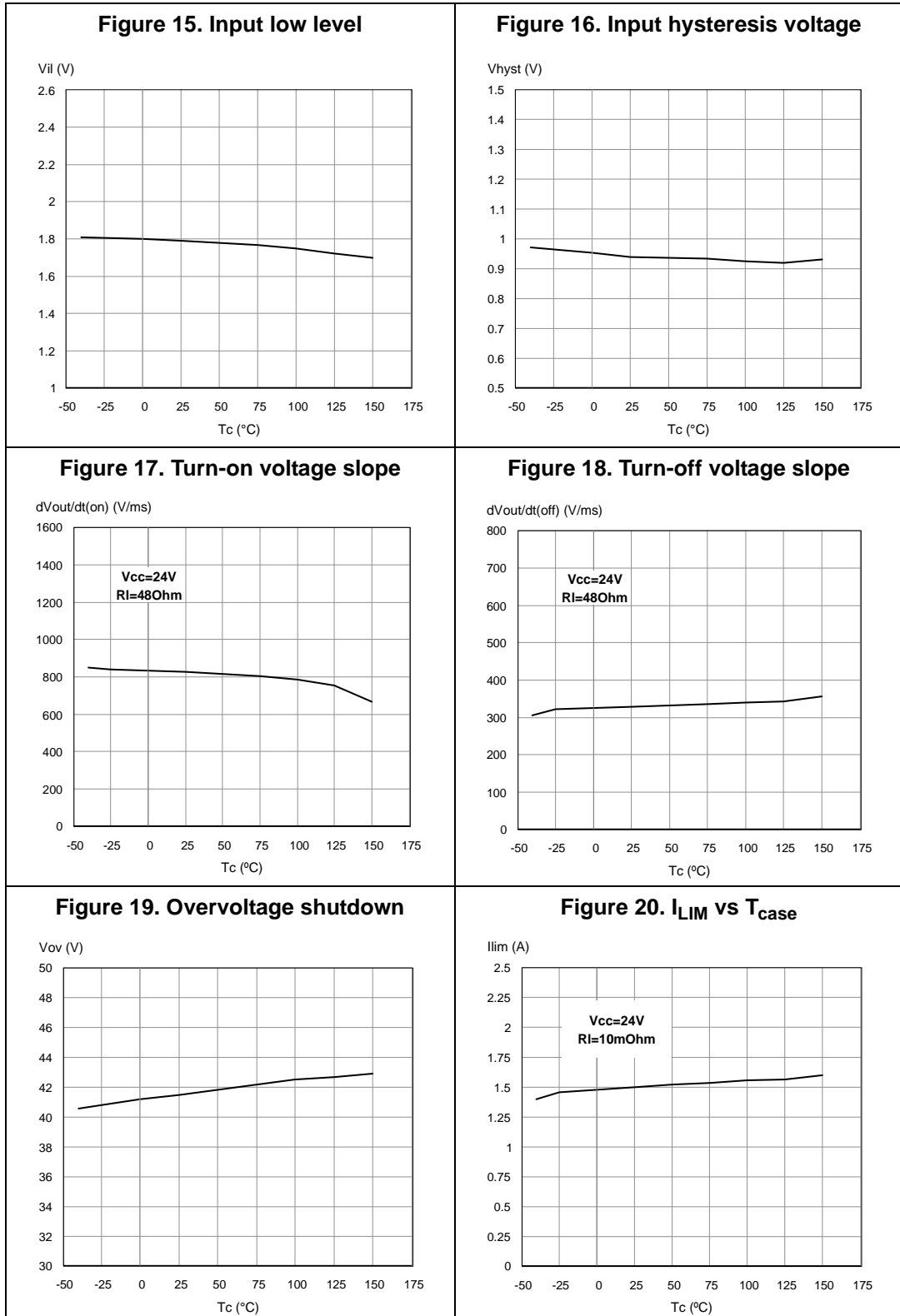



### 3.1 Application information

Figure 21. Application schematic

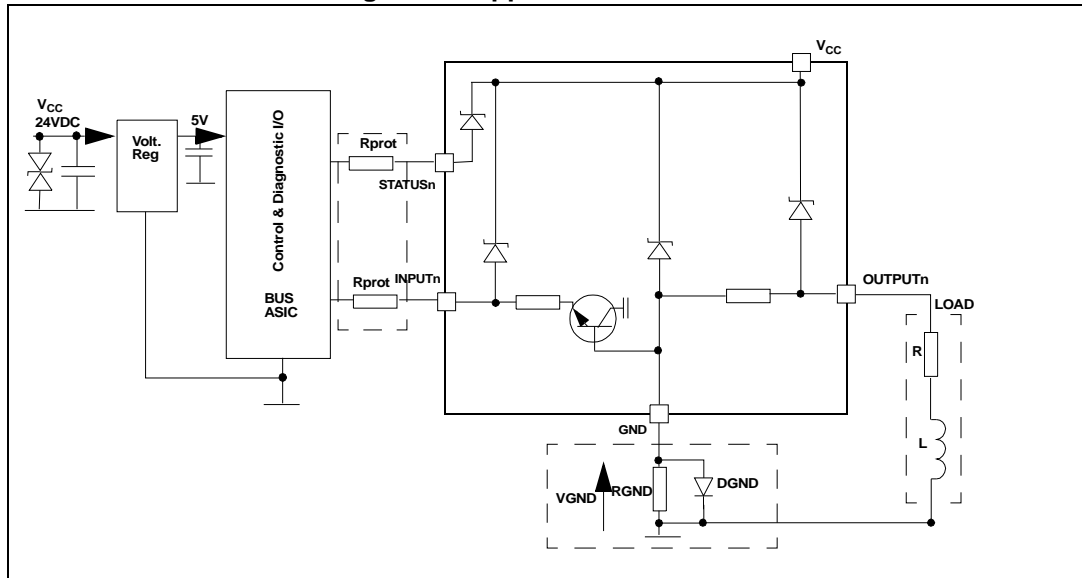

### 3.2 GND protection network against reverse battery

#### 3.2.1 Solution 1: resistor in the ground line (R<sub>GND</sub> only).

This solution can be used with any type of load

The following is an indication on how to set the dimension of the R<sub>GND</sub> resistor.

1.  $R_{GND} \leq 600 \text{ mV} / (I_{S(on)max})$ .
2.  $R_{GND} \geq (-V_{CC}) / (-I_{GND})$

where  $-I_{GND}$  is the DC reverse ground pin current and can be found in the absolute maximum rating section of the device datasheet.

Power dissipation in R<sub>GND</sub> (when  $V_{CC} < 0$ : during reverse battery situations) is:

$$P_D = (-V_{CC})^2 / R_{GND}$$

This resistor can be shared amongst several different HSD. Please note that the value of this resistor should be calculated with formula (1) where  $I_{S(on)max}$  becomes the sum of the maximum on-state currents of the different devices.

Please note that if the microprocessor ground is not common with the device ground then the R<sub>GND</sub> produces a shift ( $I_{S(on)max} * R_{GND}$ ) in the input thresholds and the status output values. This shift varies depending on the number of devices are ON in the case of several high-side drivers sharing the same R<sub>GND</sub>.

If the calculated power dissipation leads to a large resistor or several devices have to share the same resistor then the ST suggests to utilize [Section 3.3](#).

### 3.3 Solution 2: a diode (DGND) in the ground line

A resistor ( $R_{GND} = 1 \text{ k}\Omega$ ) should be inserted in parallel to  $D_{GND}$  if the device is driving an inductive load.

This small signal diode can be safely shared amongst several different HSD. Also in this case, the presence of the ground network produces a shift ( $\approx 600 \text{ mV}$ ) in the input threshold and the status output values if the microprocessor ground is not common with the device ground. This shift does not vary if more than one HSD shares the same diode/resistor network.

Series resistor in INPUT and STATUS lines are also required to prevent that, during battery voltage transient, the current exceeds the Absolute Maximum Rating.

Safest configuration for unused INPUT and STATUS pin is to leave them unconnected.

#### 3.3.1 MCU I/Os protection

If a ground protection network is used and negative transients are present on the  $V_{CC}$  line, the control pins are pulled negative. ST suggests to insert a resistor ( $R_{prot}$ ) in line to prevent the  $\mu\text{C}$  I/Os pins from latching-up.

The value of these resistors is a compromise between the leakage current of microcontroller and the current required by the HSD I/Os (Input levels compatibility) with the latch-up limit of microcontroller I/Os.

$$-V_{CCpeak}/I_{latchup} \leq R_{prot} \leq (V_{OH\mu C} - V_{IH} - V_{GND}) / I_{IHmax}$$

Calculation example:

For  $V_{CCpeak} = -100 \text{ V}$  and  $I_{latchup} \geq 20 \text{ mA}$ ;  $V_{OH\mu C} \geq 4.5 \text{ V}$

$$5 \text{ k}\Omega \leq R_{prot} \leq 65 \text{ k}\Omega$$

Recommended  $R_{prot}$  value is  $10 \text{ k}\Omega$ .

### 3.4 PPAK maximum demagnetization energy ( $V_{CC} = 13.5\text{ V}$ )

Figure 22. PPAK maximum turn-off current versus load inductance

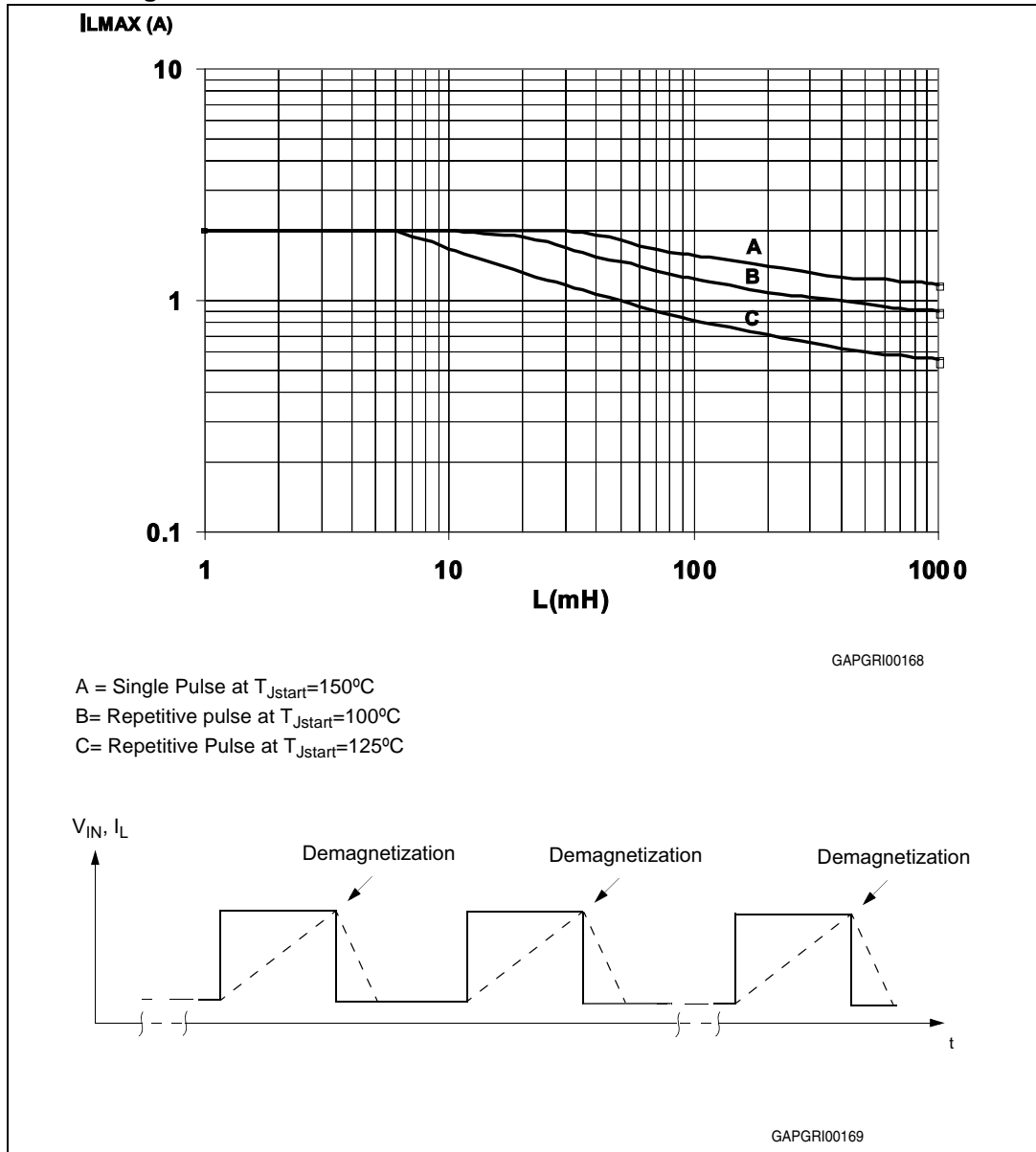

Note: Values are generated with  $R_L = 0\ \Omega$ . In case of repetitive pulses,  $T_{Jstart}$  (at the beginning of each demagnetization) of every pulse must not exceed the temperature specified above for curves B and C.

## 4 Package and PCB thermal data

### 4.1 PPAK thermal data

Figure 23. PPAK PC board

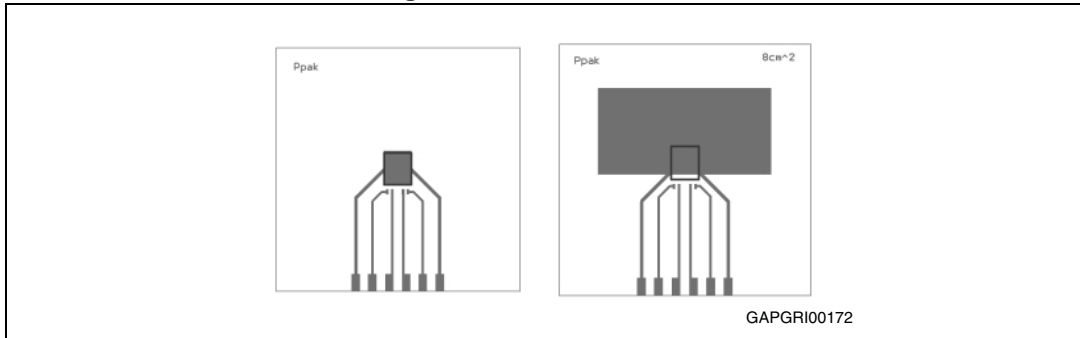

Note: Layout condition of  $R_{th}$  and  $Z_{th}$  measurements (PCB FR4 area = 60 mm x 60 mm, PCB thickness = 2 mm, Cu thickness = 35  $\mu$ m, Copper areas: 0.44 cm<sup>2</sup>, 8 cm<sup>2</sup>).

Figure 24. PPAK  $R_{thj-amb}$  vs PCB copper area in open box free air condition

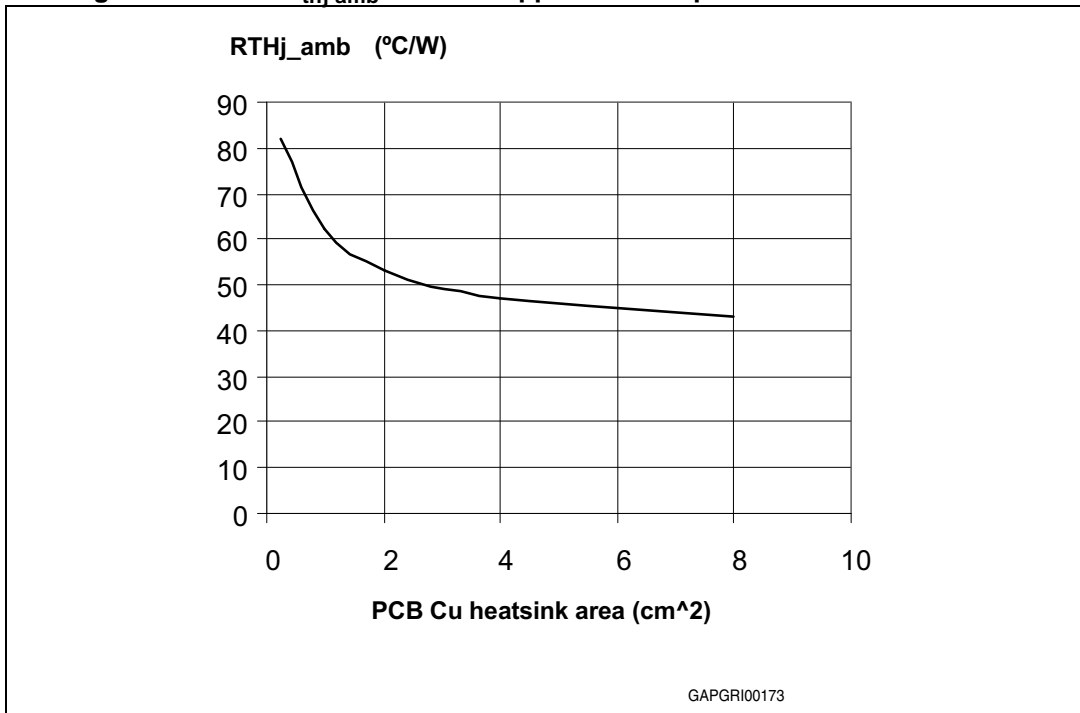

Package and PCB thermal data

VN800PT-E

Figure 25. PPAK thermal impedance junction ambient single pulse

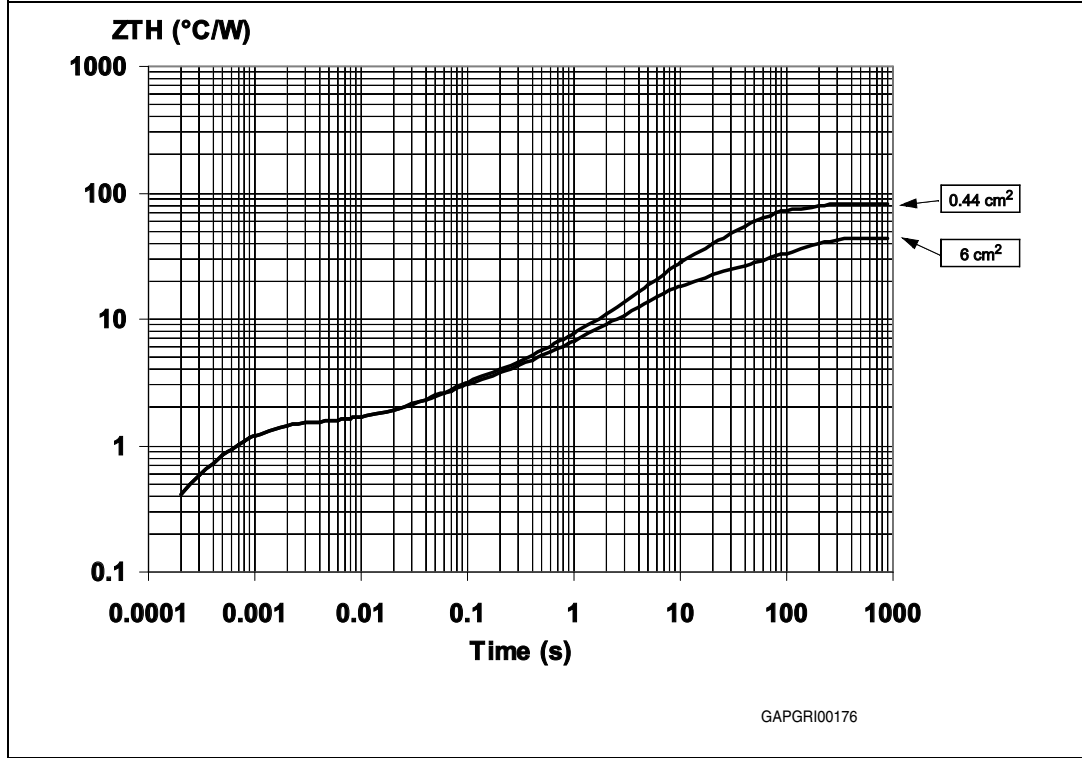

Equation 1: Pulse calculation formula

$$Z_{TH\delta} = R_{TH} \cdot \delta + Z_{THtp}(1 - \delta)$$

where  $\delta = t_p / T$

Figure 26. Thermal fitting model of a single channel HSD in PPAK

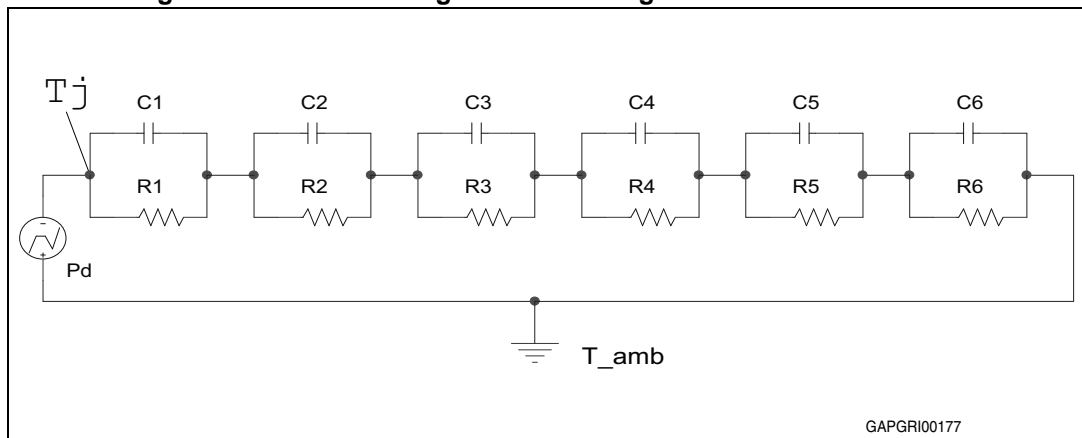

VN800PT-E

Package and PCB thermal data

Table 15. Thermal parameter

Ara/island (cm <sup>2</sup> )	0.44	6
R1 (°C/W)	0.04	
R2 (°C/W)	0.25	
R3 (°C/W)	0.3	
R4 (°C/W)	2	
R5 (°C/W)	15	
R6 (°C/W)	61	24
C1 (W.s/°C)	0.0008	
C2 (W.s/°C)	0.007	
C3 (W.s/°C)	0.02	
C4 (W.s/°C)	0.3	
C5 (W.s/°C)	0.45	
C6 (W.s/°C)	0.8	5

## 5 Package and packing information

### 5.1 ECOPACK®

In order to meet environmental requirements, ST offers these devices in different grades of ECOPACK® packages, depending on their level of environmental compliance. ECOPACK® specifications, grade definitions and product status are available at: [www.st.com](http://www.st.com). ECOPACK® is an ST trademark.

### 5.2 PPAK package mechanical data

Figure 27. PPAK package dimensions

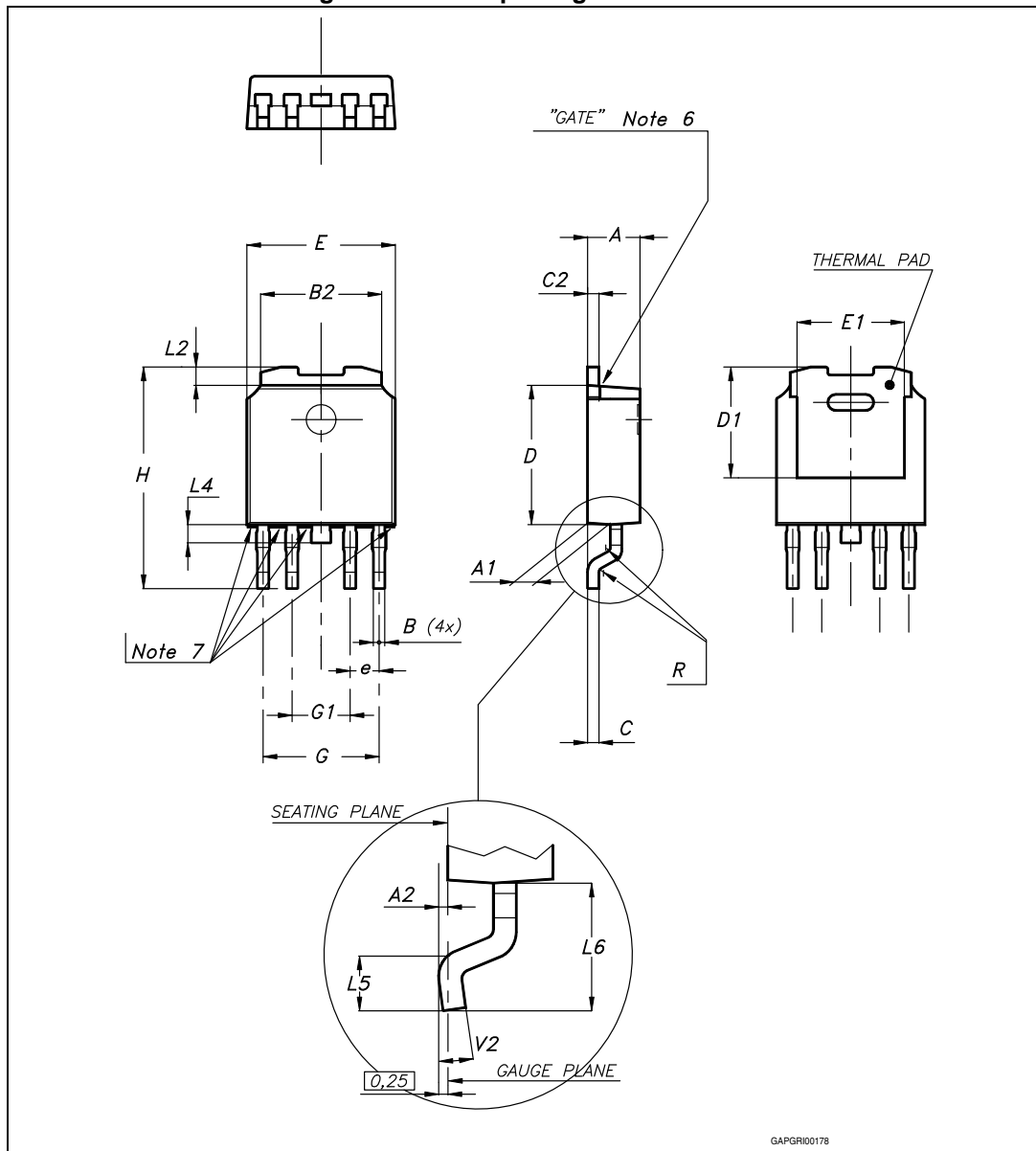

VN800PT-E

Package and packing information

Table 16. PPAK mechanical data

Symbol	millimeters		
	Min	Typ	Max
A	2.20		2.40
A1	0.90		1.10
A2	0.03		0.23
B	0.40		0.60
B2	5.20		5.40
C	0.45		0.60
C2	0.48		0.60
D	6.00		6.20
D1		5.10	
E	6.40		6.60
E1		4.70	
e		1.27	
G	4.90		5.25
G1	2.38		2.70
H	9.35		10.10
L2		0.8	1.00
L4	0.60		1.00
L5	1		—
L6		2.80	
R		0.20	
V2	0°		8°
Package Weight	Gr. 0.3		



Package and packing information

VN800PT-E

5.2.1 PPAK packing information

Figure 28. PPAK suggested pad layout and tube shipment (no suffix)

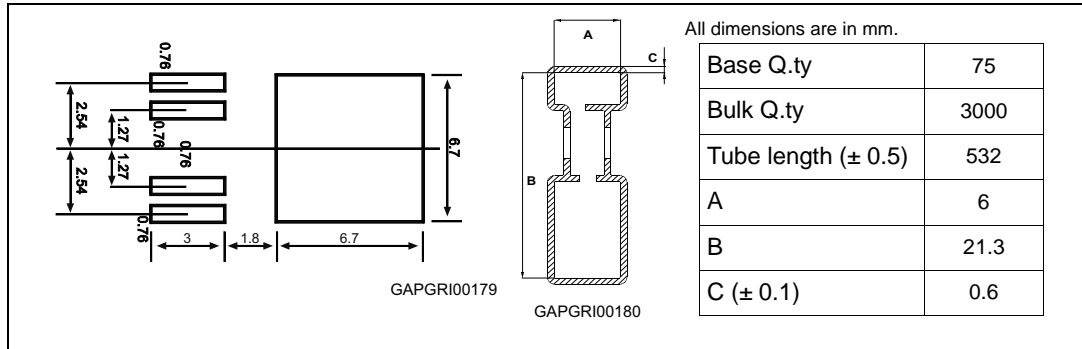
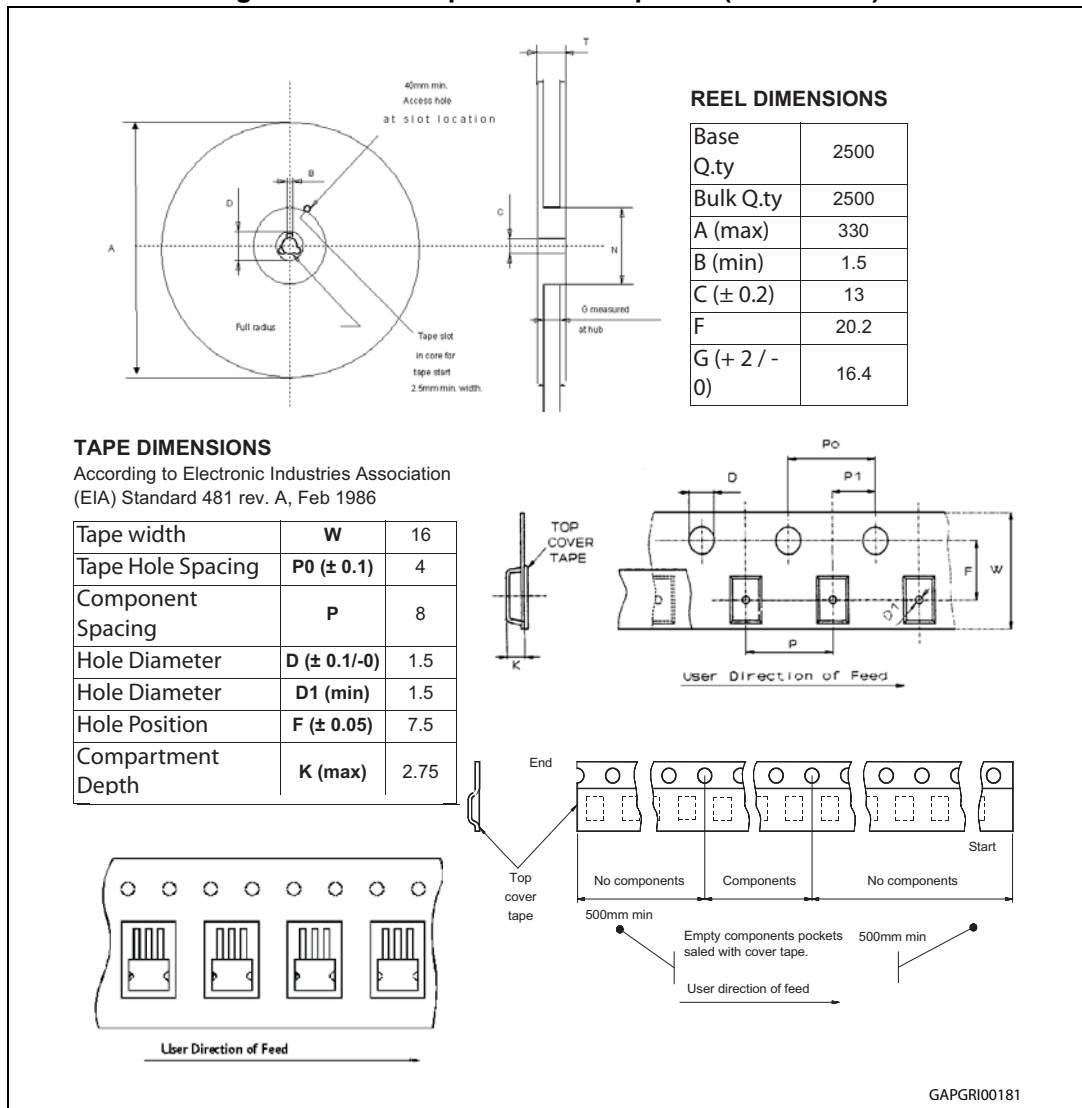

Figure 29. PPAK tape and reel shipment (suffix "TR")



## 6 Revision history

Table 17. Revision history

Date	Revision	Changes
7-Oct-2004	1	Initial release.
02-May-2012	2	Update entire document following new ST template. Update <a href="#">Figure 27</a> and <a href="#">Table 16</a> .
20-Sep-2013	3	Updated Disclaimer.
21-Oct-2014	4	The part number VN800S-E has been moved to a separate datasheet. Removed SO-8 package.

**IMPORTANT NOTICE – PLEASE READ CAREFULLY**

STMicroelectronics NV and its subsidiaries (“ST”) reserve the right to make changes, corrections, enhancements, modifications, and improvements to ST products and/or to this document at any time without notice. Purchasers should obtain the latest relevant information on ST products before placing orders. ST products are sold pursuant to ST’s terms and conditions of sale in place at the time of order acknowledgement.

Purchasers are solely responsible for the choice, selection, and use of ST products and ST assumes no liability for application assistance or the design of Purchasers’ products.

No license, express or implied, to any intellectual property right is granted by ST herein.

Resale of ST products with provisions different from the information set forth herein shall void any warranty granted by ST for such product.

ST and the ST logo are trademarks of ST. All other product or service names are the property of their respective owners.

Information in this document supersedes and replaces information previously supplied in any prior versions of this document.

© 2014 STMicroelectronics – All rights reserved